



Auto Arm | DataPRO

Q4, 2021

John Moors

Topics

34 Slides

-  Introduction | General Information & Firmware Updates
-  Power Supply and the ON Signal
-  Settings Step 1: Update System Settings
-  Settings Step 2: Configuration File
-  Create Test Setup for Auto-Arm
-  Arm a Test with Auto-Arm
-  Run Test | Boot System
-  Run Test | Multiple Power Cycles
-  Run Test | Collect Data
-  Run Test | Download Data
-  Automating START or EVENT Signals
-  Need More Help?



Introduction

Introduction

- › **Auto-Arm mode causes the unit to arm automatically when the power is cycled. This is available with any available data collection mode.**
- › **The unit will still require a START or EVENT signal to capture data, depending on the Data Collection Mode selected.**



[Click here for our article on Data Collection Modes](#)

- › **The unit can be configured to automatically start recording. Please see the Automating START or EVENT Signals section later in this presentation.**

›› Automating START or EVENT Signals

- › **This presentation walks through the auto-arm process with information on LED signals, data collection specifics, and additional modifications to the test flow**
- › **Further information on DAS operation can be found in the User's Manual**
- › **As always, if you have any questions, please submit a ticket on our Help Center. Please see the final section in this presentation for more information on support**
- › **Happy testing!**

Introduction | Firmware

- › Before proceeding, please check with DTS to either confirm your firmware is current or request the newest release
- › You can easily check the firmware version of your S6A's in the **Data Recorder** tab of DataPRO, which will show the Serial Numbers and FW Versions of all recorders you have detected and queried (saved) in the software (as well as other details)



Serial Number	Type	Connection	Channels	Firmware	Max Sample Rate	Cal Date
S6A0193	SLICE 6 AIR	192.168.4.93	6 Analog channel(s)	G0M1	400,000	8/13/2021
S6A0192	SLICE 6 AIR	192.168.4.92	6 Analog channel(s)	G0M1	400,000	8/13/2021
S6A0191	SLICE 6 AIR	192.168.4.91	6 Analog channel(s)	G0M1	400,000	8/13/2021

1

- › To confirm your version is current or if you need an update, please **Submit a Ticket** on the Help Center, providing:

- › Serial Number(s) of your SLICE6 AIR(s)
- › Current Firmware versions on each



2

- › You will need this tool and procedure to update the firmware on your SLICE6 modules



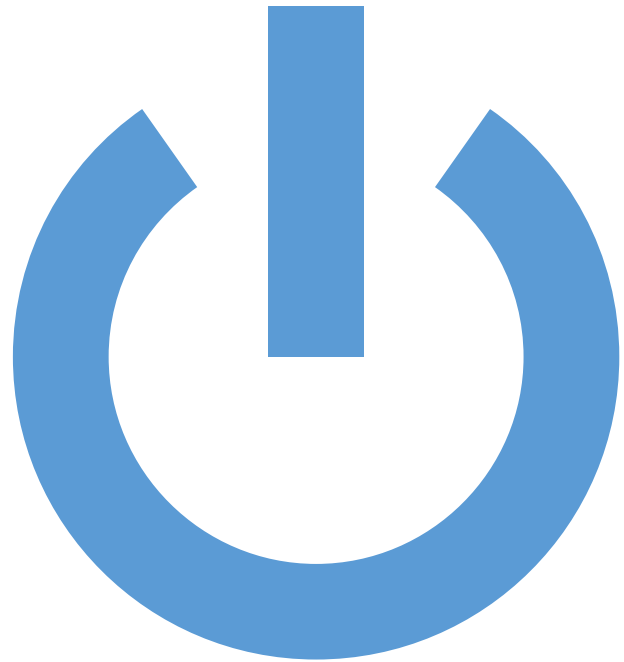

Power Supply & The ON Signal

Power Flow Diagram | Example SLICE NANO w/ Stack Battery

Supplying 12V to UP connector will charge all batteries.

A suitable battery pack may be connected to the DN connector on a NANO or MICRO Base and trickle-charged using a simple in-cable circuit.

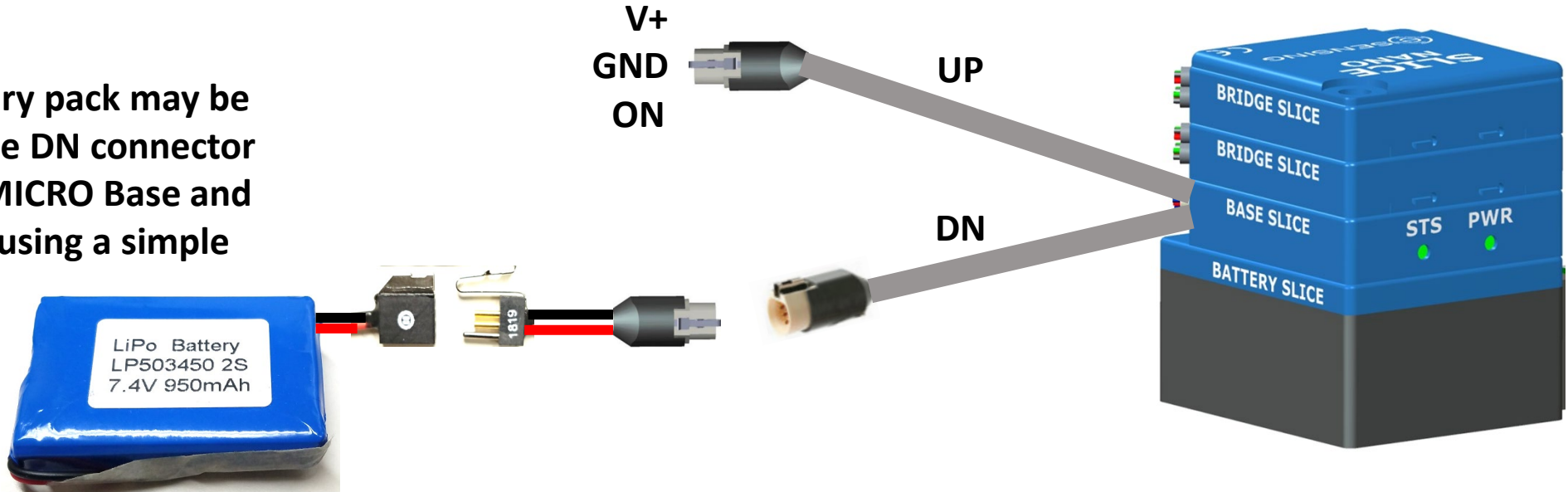

Battery Pack for Primary Power

Stack Battery for Backup Power Charges when V+ is greater than a set threshold, 10V default

Power Flow Diagram | SLICE6 Air



Processor draws 0.5-1.0 mA in “off” state.
For long-term storage, disconnect power.

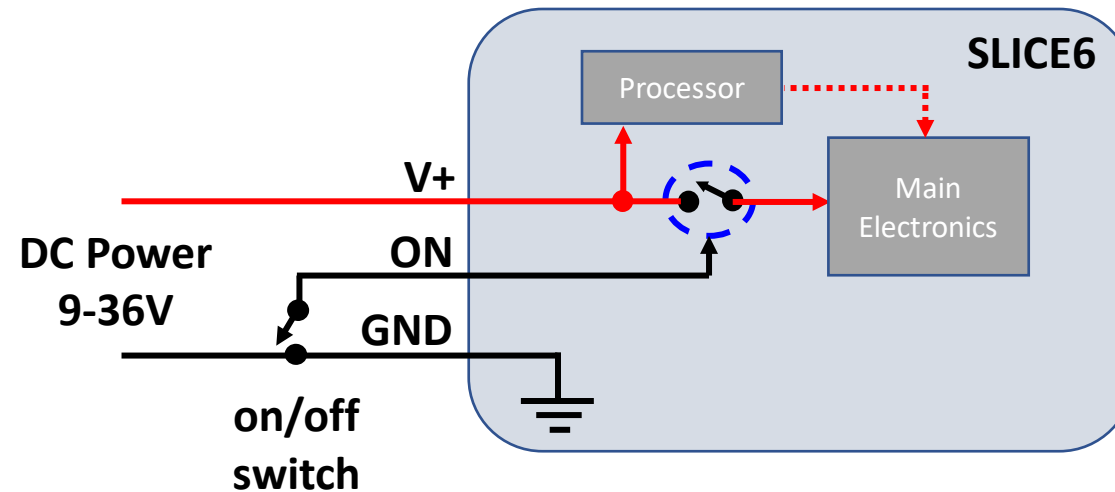

To save power but use Auto Arm, can keep ON switch closed and simply supply V+ when ready



Settings Step 1: Update System Settings

System Settings

› Select the System Settings Tab

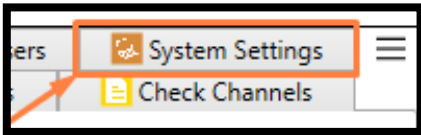

› Check the box next to “Set DAS to auto-arm”

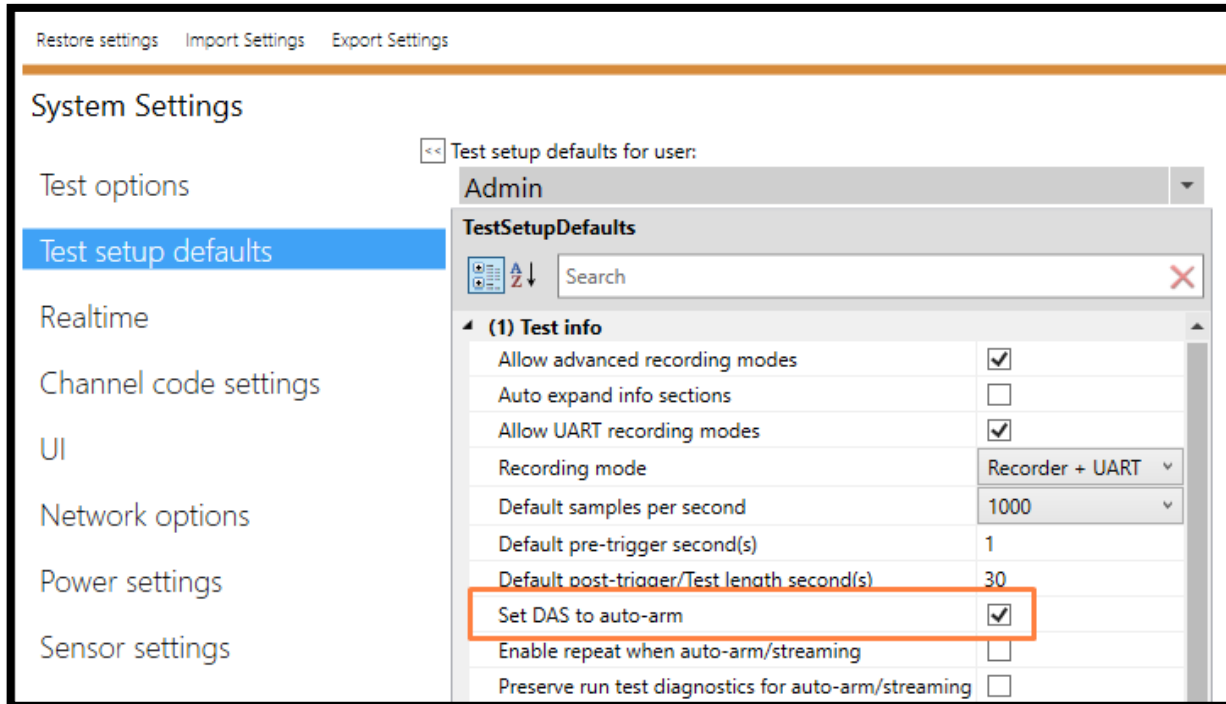



Settings Step 2: Set Auto Arm Value in Config File

Configuration File

- › Make sure DataPRO is closed
- › Navigate to your C Drive location below (version will vary) to open the DataPRO.exe configuration file
 - › C:\DTS\DTS.Suite\3.1.472\DataPRO

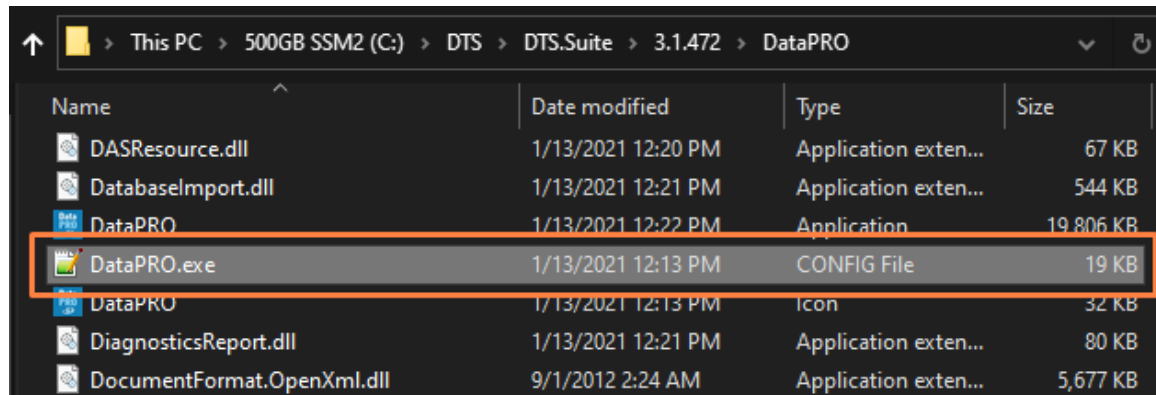

- › Open the file using a text editor (below shots are from Notepad++) and search for AllowAutoArm:

```
251 <setting name="AllowAutoArm" serializeAs="String">  
252 <value>False</value>  
253 </setting>
```

- › Change to "True" and save the Configuration File

```
251 <setting name="AllowAutoArm" serializeAs="String">  
252 <value>True</value>  
253 </setting>
```

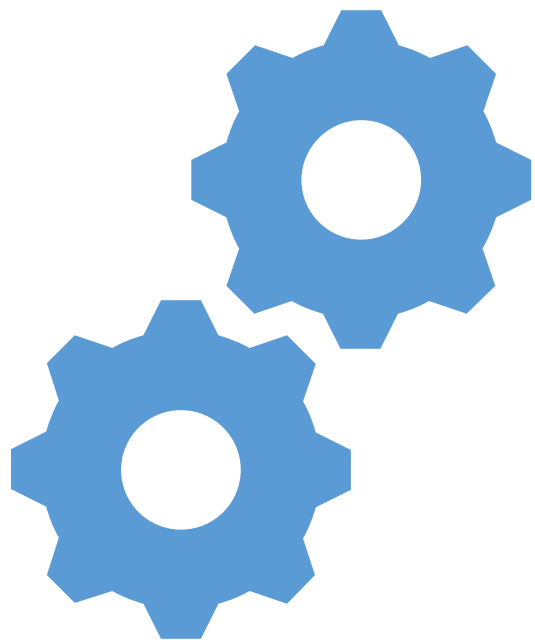

Create Test Setup for Auto-Arm

Test Setup for Auto-Arm

- › Create a new Test Setup, and check the box for Set DAS to Auto-Arm

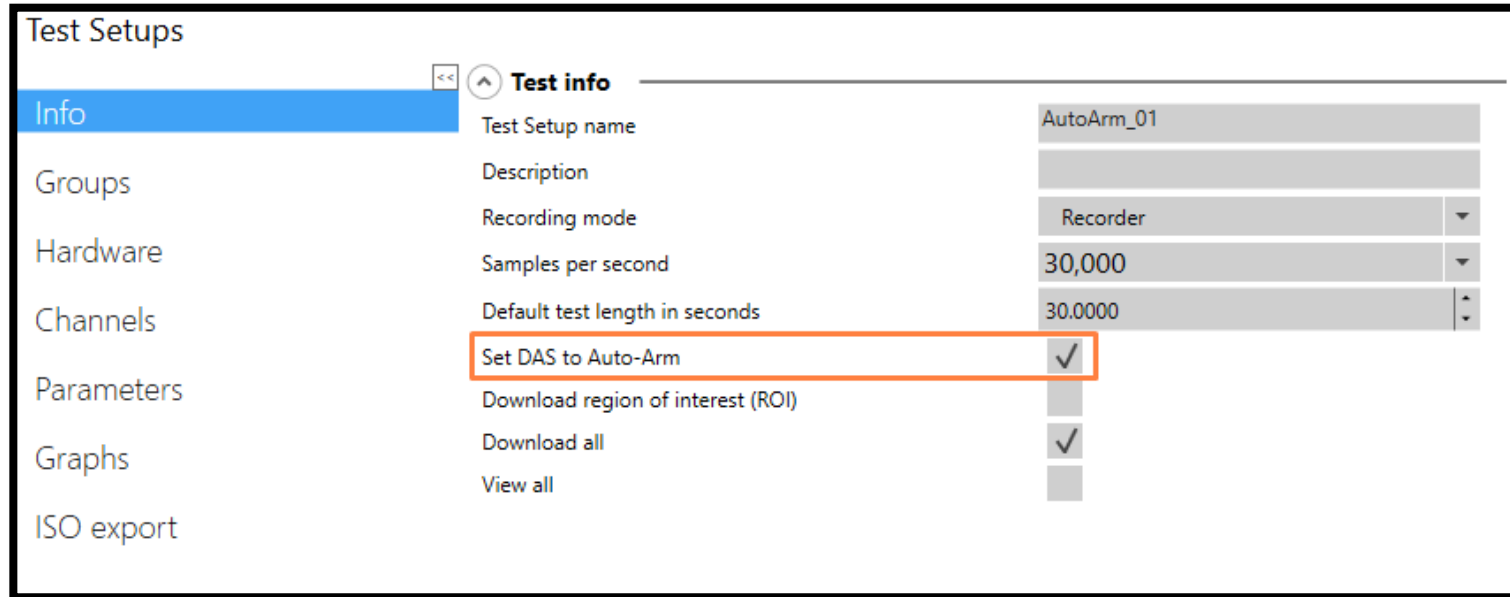

The screenshot shows a web-based configuration interface for a test setup. On the left is a navigation menu with options: Info (selected), Groups, Hardware, Channels, Parameters, Graphs, and ISO export. The main area is titled 'Test info' and contains the following fields:

Field	Value
Test Setup name	AutoArm_01
Description	
Recording mode	Recorder
Samples per second	30,000
Default test length in seconds	30.0000
Set DAS to Auto-Arm	<input checked="" type="checkbox"/>
Download region of interest (ROI)	<input type="checkbox"/>
Download all	<input checked="" type="checkbox"/>
View all	<input type="checkbox"/>

- › Setup the rest of the test as you would normally

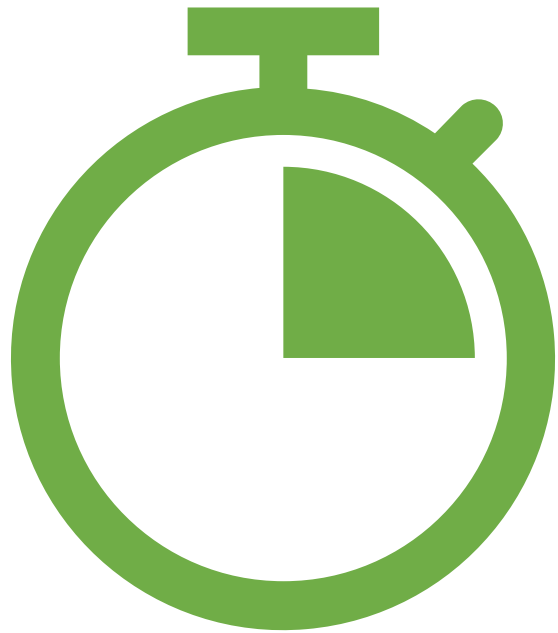

Arm a Test with Auto Arm

Test with Auto-Arm | Arming Pre-Power Cycle

1. Run Test using the Test Setup created previously. Once at the Arm section, select RUN. You will see a pop-up confirm the units can now be disconnected and will auto-arm with the ON signal:

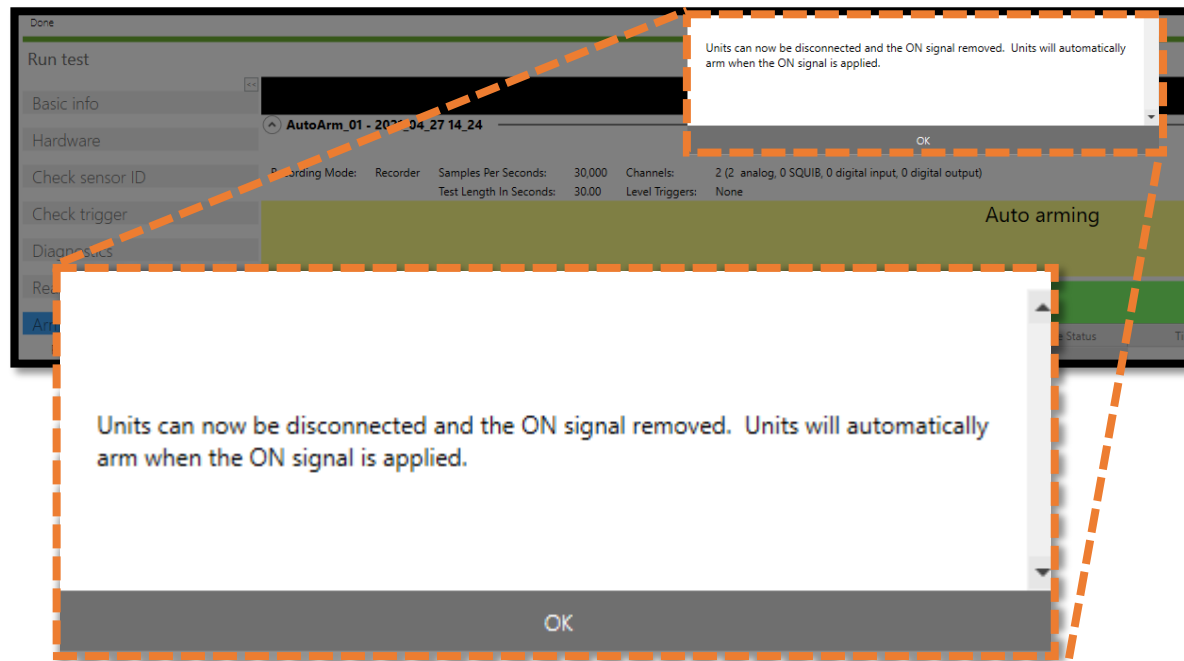

Test with Auto-Arm | Arming Pre-Power Cycle



- 2. Disconnect DAS. Either close DataPRO or leave open depending on your connection:**
 - › USB Connection: Select Done and Close DataPRO
 - › Ethernet Connection: You can leave DataPRO open in the Run Test page or click Done and close DataPRO.
- 3. Power OFF your DAS until time for test, then proceed to Step 4**



Run Test Boot System





Run a Test with Auto-Arm | Run Test





4. **To Arm DAS:** Turn the DAS on, either by connecting power (if ON signal already shorted to ground) or short ON signal to ground (if power already supplied)
5. **Wait for DAS to Boot.** The boot sequence will take at least 20 seconds. The system will load its firmware, and then self-configures per the test setup during arming as well as running some basic diagnostic checks. At system power up, the STATUS LED cycles from red to green to blue followed immediately by the POWER LED boot-up sequence.

ACTION	DAS	STATUS LED (STS)	STATUS LED (PWR)
BOOT SEQUENCE	NANO/MICRO & SLICE6 AIR		

Run a Test with Auto-Arm | Run Test

6. The boot sequence will take at least 20 seconds. Once the sequence is complete, the LED's will indicate the system is ready to begin capturing data.

ACTION	DAS	CONNECTED TO PC	STATUS LED (STS)	STATUS LED (PWR)
BOOT COMPLETE ARMED RECORDER MODE	NANO/MICRO & SLICE6 AIR	YES		
		NO		

ACTION	DAS	CONNECTED TO PC	STATUS LED (STS)	STATUS LED (PWR)
BOOT COMPLETE ARMED CIRCULAR BUFFER	NANO/MICRO & SLICE6 AIR	YES		
		NO		

ACTION	DAS	CONNECTED TO PC	STATUS LED (STS)	STATUS LED (PWR)
BOOT COMPLETE NOW STREAMING	SLICE6 AIR	YES		





Run Test

Multiple Power Cycles

Run a Test with Auto-Arm | Multiple Power Cycles



If your test will only use one Power Cycle, skip to Step 8

7. Multiple Power Cycle

- › If the DAS reaches fully armed state and then the ON signal is removed, the unit will remain ON and ARMED until the mission is complete
- › If the Power Supply is removed, the DAS will Power OFF (**see exception below**)
 - › **Stack Battery (NANO Only):** If this battery is connected, the unit will remain ON and ARMED until the battery is depleted
- › If the Power Supply is re-applied the DAS will Boot and Arm again (assuming the Enable repeat when auto arm/streaming check box was checked in System Settings)



Run Test







Collect Data

Test with Auto-Arm | Collect Data | Recorder Mode

8. To Begin Recording: Supply **START** Signal. LED's will confirm signal received.

- › Optional: Supply EVENT/TRIGGER Signal. LED's will confirm signal received.

 For **Circular Buffer**, see next slide

ACTION	DAS	STATUS LED (STS)				POWER (PWR) LED	
		ARMED – WAITING FOR START SIGNAL <i>(Not Taking Data)</i>	START SIGNAL RECEIVED <i>(Recording Data)</i>	EVENT SIGNAL RECEIVED <i>(Remains on until collection complete)</i>	COLLECTION COMPLETED <i>(OFF)</i>	CONNECTED TO PC	
DATA CAPTURE RECORDER MODE	NANO/MICRO & SLICE6 AIR					YES	
						NO	

9. Wait for DAS to complete Data Collection, using the steps below to confirm:

- › Ensure the TOTAL time you requested for data capture has passed.
- › LED's will confirm signals received and capture completion (see above)

Test with Auto-Arm | Collect Data | Circular Buffer

8. To Begin Recording: Supply **EVENT/TRIGGER** Signal. LED's will confirm signal received.



For Recorder Mode, see previous slide

ACTION	DAS	STATUS LED (STS)			POWER (PWR) LED	
		ARMED – WAITING FOR EVENT SIGNAL <i>(Collecting Data)</i>	EVENT SIGNAL RECEIVED <i>(Remains on until collection complete)</i>	COLLECTION COMPLETED <i>(OFF)</i>	CONNECTED TO PC	
DATA CAPTURE CIRCULAR BUFFER	NANO/MICRO & SLICE6 AIR				YES	
					NO	

9. Wait for DAS to complete Data Collection, using the steps below to confirm:

- › Ensure the TOTAL time you requested for data capture has passed.
- › LED's will confirm signals received and capture completion (see above)



REMINDER: In **Circular Buffer**, the DAS is constantly capturing data until the memory is full. Your total Data to be saved is simply the sum of both your Pre and Post Trigger time. Your TRIGGER/EVENT signal, therefore, is critical to retrieve your data.

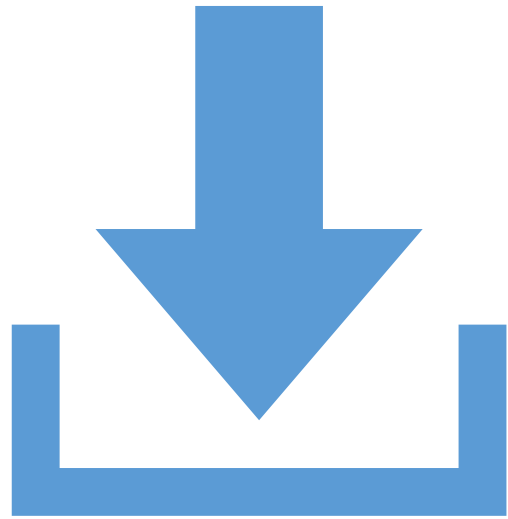

Run Test

Download Data

Download Data

- › **Connect DAS to PC to resume communication and download data based on connection:**
 - › **USB Connection** › Open DataPRO and select the Download Data tab. Proceed through the steps on the left to download the data

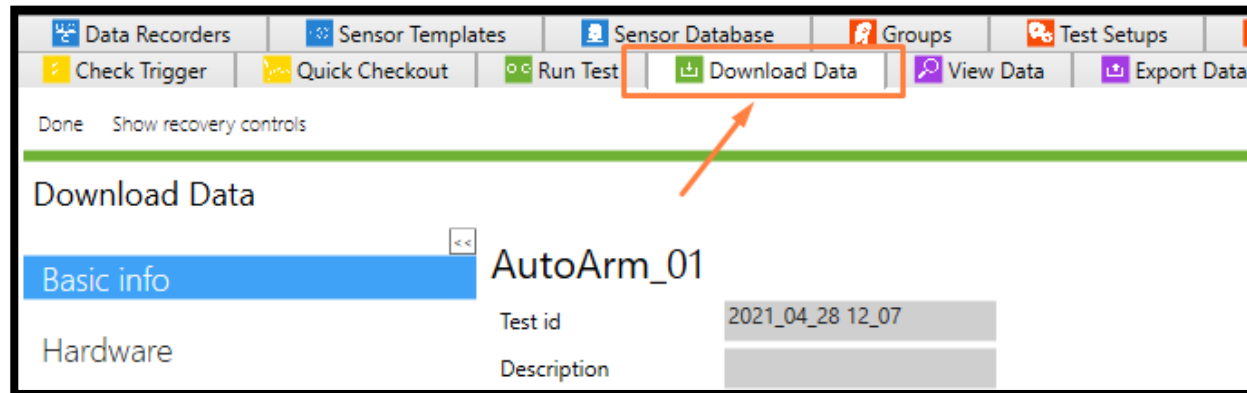

- › **Ethernet Connection** › If DataPRO still open and in the Run Test page, select Start Monitoring. You can then proceed with downloading data. If for some reason DataPRO was closed, use the USB Connection method above



Automatically Record On Boot-Up

Automatically Record on Boot-Up

- › For the system to begin recording as soon as it boots, the START signal can be shorted and appropriate settings need to be changed

- › **Please reach out to DTS so that we can confirm the settings are ideal for your setup**



Click here to Submit a ticket on the Help Center

- › **If an event signal is applied to the event input or a level trigger is met, the time will be realigned to zero.**



Click here for our article on Data Collection Modes



START and EVENT signals may be provided by an external sequencing device or via software commands such as those available in the DTS API. Please reach out to DTS if you would like to pursue this method





Need More Help?

Need More Help?

- › We have support engineers in multiple time zones with various backgrounds who can assist. Registering creates a profile for your setup and keeps your records/requests organized going forward. You don't need to be registered to submit a Help Ticket, but it keeps all your info in one place.
 - › Here's how to get started. [The buttons below will take you directly to the specific web pages.](#)
1. Head to our Help Center main page for support resources.
 2. Register as a new user.
 3. Submit a Help Ticket. You can CC members of your organization, attach files, and add any helpful links.
 4. Feel free at any time to check out our Knowledge Base. It has articles, videos, and breakdowns of our hardware and software, as well as general information and best practices. We're frequently updating this library to keep users informed.
 5. Our Video Library has Webinar Recordings, Product Overviews, and Training. If you'd like to join a future webinar, let us know!

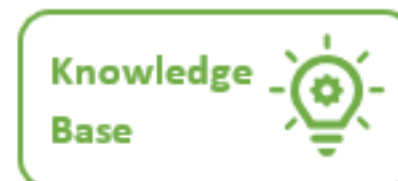

THANK YOU

