



DataPRO User Manual



Version 4.4

April 2025

Contents

DTS Support	7
Introduction	8
PC Requirements	8
Software Installation	9
Database Configuration	10
Local Database	10
Centralized Database	12
Both Local and Centralized Databases	13
Launching DataPRO	14
Licensing	15
Data Collection Concepts	17
Data Collection Modes	17
Circular Buffer Mode.....	18
Recorder Mode	18
Hybrid Recorder Mode.....	18
Multiple-Event Modes	18
Continuous Recorder Mode	18
Circular and Stream Mode	19
Recorder and Stream Mode.....	19
Hybrid and Stream Mode	19
Active Mode	19
Scheduled Mode	19
UART Modes	20
Record on Boot Mode.....	20
Auto Arm.....	20
Streaming	21
Sampling Rates	22
How to Calculate Maximum Recording Time	24
SLICE Circular Buffer Limitations	26
Navigating DataPRO	27

Tab Options.....	28
Status Bar.....	31
Hamburger Menu.....	31
Quick Start.....	32
Physical Hardware	33
Data Recorders	33
Detect.....	33
Add.....	37
Hardware Usage Report	43
Sensor Templates	46
Add.....	46
Sensor Database.....	52
Import.....	53
Add.....	56
Export.....	64
Prepare.....	66
Groups	66
Add.....	66
Import	77
Export	79
Test Setups	83
Add.....	83
Import	113
Export.....	116
Quick Build.....	118
Change Test Setup.....	121
Refresh.....	121
Layout Report	122
Additional Details.....	123
Lab Details.....	123
Customer Details.....	124
Engineer Details.....	125
Channel Code Details.....	125
Diagnostics	127

Check Channels	128
Realtime - Level Triggers Off	133
Realtime - Level Triggers On	138
Check Trigger	140
Quick Checkout	144
Record	148
Run Test	148
Download Data	173
Review	175
View Data	175
Viewer Layout	175
Selection Pane.....	182
Chart Pane.....	190
Modification Pane.....	193
Generate Reports.....	197
Export Data	198
Copy & Trim.....	203
Copy & Rename.....	205
Administrative	206
Manage Users	206
System Settings	210
Test Settings	210
Test Setup Settings	219
Test History Settings	230
Realtime Settings	231
Channel Code Settings.....	234
UI Settings	235
Power Settings.....	237
Sensor Settings.....	238
Advanced Settings	243
Database	245
Restoring, Importing, and Exporting System Settings.....	247
Appendix A: Common Sensor Types and Bridge Connections	249

Accelerometer	249
Upper Neck Load Cell	249
ARS – Angular Rate Sensors	250
Linear Potentiometer.....	250
Non-linear Devices	250
INTRACC for WorldSID and THOR dummies	251
Digital Input/Output Options	251
Squib Options	251
Sensors with External Conditioning Modules.....	251
Appendix B: Sensor Database Import	262
Command Line Import.....	263
Syntax	263
Parameters	263
Example.....	263
File Format.....	264
Log File Format.....	265
Appendix C: Discover Hardware	266
Appendix D: Quick Arm.....	272
Appendix E: DataPRO File Structure	275
Appendix F: DataPRO .dts File Format	279
Appendix G: DataPRO Binary File Format.....	286
Appendix H: SQL Server Setup	288
SQL Server Express Installation	288
Windows 11 Support	296
SQL Server Management Studio Installation	297
Firewall Configuration.....	302
SQL Server Configuration Manager	305
SQL Server Management Studio.....	308
Connecting to the DataPRO Database	313
Using SQL Server for the DataPRO Database	317
Backing Up the Centralized (SQL Server) DataPRO Database	318

Restoring the Centralized (SQL Server) DataPRO Database	323
Appendix I: SLICE6 AIR Setup	327
Hardware Settings.....	327
DataPRO Settings.....	328
Test Setup Configuration	329
Record In Place with Analog and UART data.....	331
Streaming Data with SLICE6 AIR.....	332
Running a SLICE6 AIR Streaming Test.....	334
Streaming Data via UART.....	342
Appendix J: TSR AIR Setup	344
Test Setup Configuration	344
Info.....	344
Channels	345
Parameters	346
Level Triggers.....	347
Diagnostics	348
Appendix K: Device Fault IDs	349
Appendix L: Test Setup Import	351
Test Setup Table	351
Sensor Table	353
Clock Settings Table	359
DAS Settings Table	362
Appendix M: Unipolar Sensors	363
Document Revision History	366

DTS Support

DTS systems are designed to be reliable and simple to operate. If you ever need assistance, DTS has support engineers worldwide with extensive product knowledge and test experience ready to help.

- Registered users can access the DTS Help Center web portal: support.dtsweb.com

Registration also gives you access to additional self-help resources and non-public support information. To register, go to support.dtsweb.com/registration.

Introduction

This manual supports the DataPRO software application, part number 10920-04010.

DataPRO is a comprehensive software application that supports SLICE PRO, SLICE 6, SLICE6 AIR, SLICE MICRO/NANO and legacy TDAS PRO and TDAS G5 hardware. DataPRO allows seamless integration of SLICE and TDAS systems in a single test setup. Suitable for both small facility and multi-user lab settings, DataPRO includes extensive diagnostics and hardware checks, a customizable user interface with access control, support for sensor templates and group templates, an off-line test builder, and multiple data export formats.

Please contact DTS Support for the latest software information.

PC Requirements

DataPRO is a Windows®-based program. Minimum PC specifications are:

- Windows 8 and later (64-bit). *Please note that support for Windows 8 ended on January 12, 2016, and support for Windows 8.1 ended on January 10, 2023, so Windows 10 is highly recommended. 32-bit systems are no longer supported as of DataPRO version 4.0.*
- Microsoft .NET Runtime version 4.5.2
- Microsoft SQL Server 2014 Express or later
- Intel-compatible processor with minimum speed of 1.6 GHz; 1.8 GHz recommended
- 8 GB RAM; 16 GB recommended (more RAM is important for high channel counts and longer/higher sample rates)
- 2 GB disk space for DataPRO, plus 4.2 GB for SQL Server 2014 Express, plus additional storage as needed for test data
- 1366 x 768 minimum screen resolution; 1920 x 1080 recommended

Additionally, DTS recommends a network that supports gigabit Ethernet (GbE).

NOTE: DTS recommends setting the PC power plan to High or Max Performance for best response when in Realtime.

NOTE: Later versions of SQL Server Express may have different minimum requirements. Refer to Microsoft's documentation for details.

Software Installation

During installation, DataPRO can be configured to work with a local database, a centralized SQL server database, or both. If installing with a local database, the existing database can be migrated during installation. It may be necessary to contact facility IT in order to install a centralized SQL server database.

Initial installation steps, as well as completing installation and launching the software are the same regardless of database configuration.

1. Locate the installation files (e-media or downloaded from the Help Center).
2. Run the setup file to install DataPRO.

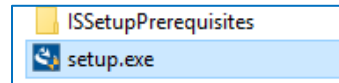

3. Follow the prompts to:
 - a. Start InstallShield Wizard for DataPRO.
 - b. Install drivers if necessary.
 - c. Change the install directory if desired.

NOTE: The default installation location for DataPRO is C:\DTS\DTS.Suite\ and is organized in folders by version number.

NOTE: The configuration file DataPRO.exe.config will be automatically updated from the previous installed version. To install DataPRO with a non-migrated config file, simply rename the config file in the previous installation before running the installer.

4. If a DataPRO license was included with the installer, or if you are upgrading from a previous version which contains a license, the license will be copied automatically. Otherwise, you will see a message indicating that no license was found. Click OK to proceed.

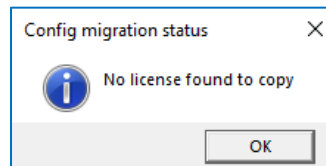

Database Configuration

Next, choose whether DataPRO will use a local database, centralized database, or both.

Local Database

5. Select **Local database**.

The following database properties will be used:

- Local database
- Centralized database
- Both

The following database properties will be used:

- Copy data from previous Local database to new Local database
 - Copy configuration from previous installation
- Initialize database to Aero settings
- Initialize database to Crash settings
- Initialize database to TSR AIR settings
- Start with blank database

Database hostname:

Database name:

Use NTLM authentication

Database user:

Database password:

Show password

OK Abort

6. Choose whether to copy data from a previous local database, initialize the database to Aero, Crash lab, or TSR AIR settings, or start with a blank database.
- Copy data from previous Local database to new Local database** will migrate the database from the previous version of DataPRO for use with the version being installed.
 - Initialize database to Aero settings** will set up the database with settings common for SLICE 6 AIR streaming and aerospace tests. The user “AeroUser” (default password: “AeroUser123”) should be used to log in and stream or collect data.

- c. **Initialize database to Crash settings** will set up the database with settings common for crash lab use. The user “CrashUser” (default password: “CrashUser123”) should be used to log in and collect data.
- d. **Initialize database to TSR AIR settings** will set up the database to use and record data with TSR AIR devices. The user “TSRAIRUser” (default password: “TSRAIRUser123”) should be used to log in and collect data.
- e. **Start with blank database** will not initialize the database at all, and the installation will have a blank database.

NOTE: See [Manage Users](#), page 206, for more information on these user roles.

- 7. When starting with a new database (blank or pre-initialized for Aero, Crash, or TSR AIR) you may optionally check the box to **copy configuration from previous installation**. This will migrate only the configuration settings from the previous database. Configuration settings are always copied when copying a previous local database.

NOTE: It is advised to use “DataPro” as the Database name.

- 8. Select **OK**, then **Finish** to complete DataPRO installation.

Centralized Database

NOTE: SQL Server must be set up and connected to a database prior to installation. See [Appendix H: SQL Server Setup](#), page 288, for additional information on SQL Server initial setup.

5. Select **Centralized Database**.

DataPRO Database Information

The following database properties will be used:

Local database

Centralized database

Both

Copy data from previous Local database to new Local database

Copy configuration from previous installation

Initialize database to Aero settings

Initialize database to Crash settings

Initialize database to TSR AIR settings

Start with blank database

Database hostname:
your db host here

Database name:
DataPro

Use NTLM authentication

Database user:
DataPROUser

Database password:
●●●●●●●●

Show password

OK Abort

- a. Enter Database hostname.
 - b. Select the option to use NTLM authentication, or enter user login credentials.
6. Optionally, check the box to **copy configuration from previous installation**. This will migrate only the configuration settings from the previous database.
7. Select **OK**, then **Finish** to complete DataPRO installation.

Both Local and Centralized Databases

NOTE: SQL Server must be set up and connected to a database prior to installation. See [Appendix H: SQL Server Setup](#), page 288, for additional information on SQL Server initial setup.

See [System Settings](#), page 238, for information on database connection when using “Both”.

5. Select **Both**.

The following database properties will be used:

- Local database
- Centralized database
- Both

Copy data from previous Local database to new Local database

- Copy configuration from previous installation
- Initialize database to Aero settings
- Initialize database to Crash settings
- Initialize database to TSR AIR settings
- Start with blank database

Database hostname:
your db host here

Database name:
DataPro

Use NTLM authentication

Database user:
DataPROUser

Database password:
••••••••

Show password

OK Abort

a. Enter **Database hostname** and **Database name**.

b. Select to use NTLM authentication or enter user login credentials.

6. Choose whether to copy data from a previous local database or start with a blank database.

a. **Copy data from previous Local database to new Local database** will migrate the local database from the previous version of DataPRO for use with the version being installed.

b. **Start with blank database** will not initialize the local database at all, and the installation will have a blank database.

7. Select “OK”, then “Finish” to complete DataPRO installation.

NOTE: You can change the Database type at any moment. See [Database](#), page 245, for more information.

Launching DataPRO

8. When installation is complete, open DataPRO using the desktop icon or Start menu:

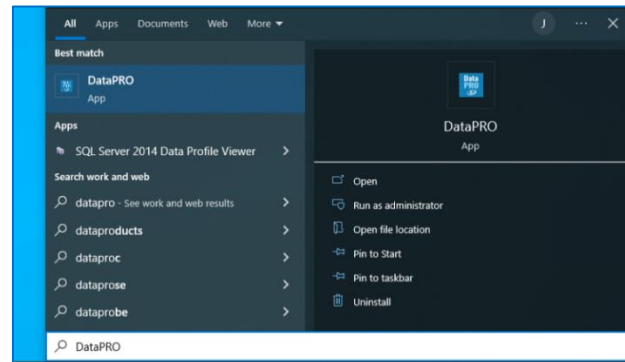

NOTE: Windows may ask you to reinstall the hardware driver each time you connect a SLICE Stack to a different USB port.

The splash screen will briefly display when launching DataPRO. This screen shows both the build version of DataPRO as well as the corresponding database version that is native to that build. With LTS (Long Term Support) DataPRO 4.x versions can operate with both older and newer databases. The actual version of the attached database can be viewed after the application starts.



NOTE: DataPRO 4.1 can operate with any database version in the 4.0 LTS life cycle. This manual assumes you are using a database version designed for the current version of DataPRO. Some features may not be available when using an older database.

9. Log in as the Administrator (Admin). The default Admin password is “DTSAAdmin” (without the quotes). *This password can be changed in the System Settings tab after logging in.*
 - a. If the database was migrated during installation, all user profiles will be available with the same passwords and settings. All previously stored sensors, test setups, and system settings will also be available.
 - b. Features and functions available to all other users are controlled by the DataPRO Administrator (see [Manage Users](#), page 206).



Licensing

DataPRO requires a license to receive support and maintenance updates. A variety of different license forms are available, including seat licenses and site licenses. Contact DTS Sales and support to obtain a license.

NOTE: Licenses may be packaged with the installer for new installations. When upgrading to a new version of DataPRO, the license is automatically copied from the existing install when upgrading from a version which contains a license.

- The current license level and status is shown in the status bar at the bottom of the application.

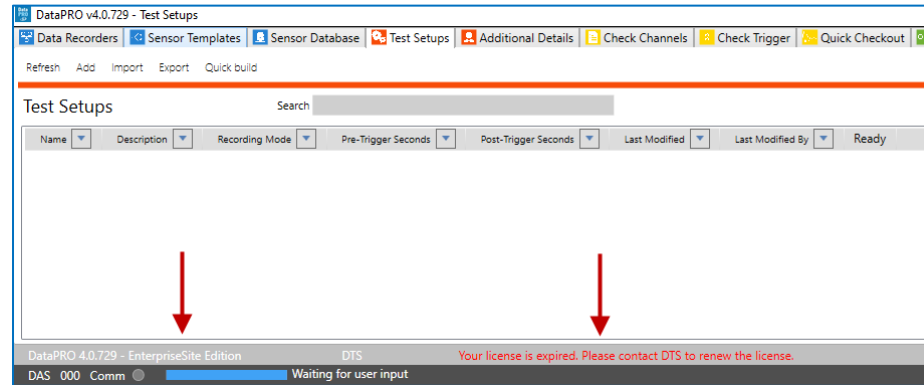

- DataPRO can still be used with a local database without a license, or as normal with an expired license.
- Users will see an information prompt when logging in to DataPRO with an expired license. This prompt can be dismissed and prevented from reappearing.

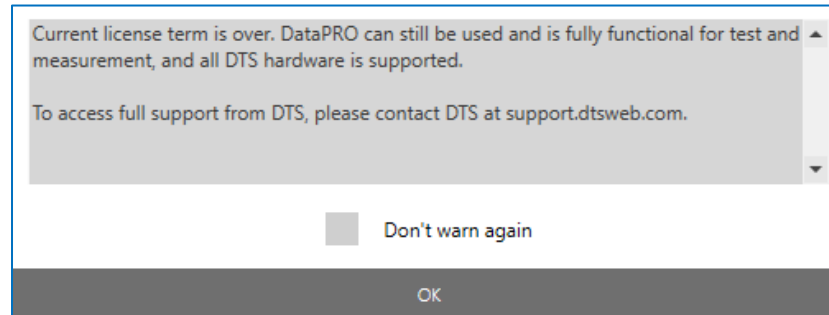

- The license warnings may be disabled or reenabled in System Settings -> UI Settings.

Data Collection Concepts

SLICE and TDAS DAS are standalone data loggers. Once the DAS is armed, the PC may be disconnected. However, DAS must remain powered throughout data collection. Power can be supplied from internal batteries when available, or from an external power supply. After receiving a Start Record or Event (trigger) signal, the DAS autonomously collects data, storing it to memory with no user interaction. After the test, the user can reconnect the PC to download the data.

DataPRO includes a Realtime mode that allows the user to check channel inputs on an oscilloscope-style screen. Realtime also includes an optional audible beep that can be used to help complete polarity checks on systems (See [Realtime - Level Triggers Off](#), page 133, for more information).

NOTE: DataPRO is capable of logging real-time data at a low sample rate but cannot simultaneously display the data while the system is recording (See [Check Channels](#), page 128, for more information).

DataPRO supports a Streaming Mode for use with SLICE6 AIR DAS (See [Appendix I: SLICE6 AIR](#), page 327).

Data Collection Modes

By default, four data collection modes are available: 'Circular buffer', 'Recorder', 'Circular buffer multiple-events', and 'Recorder multiple-events'.

Additional modes can be enabled in in [System Settings](#) -> [Test Setup Settings](#):

- If 'Allow advanced recording modes' is checked, 'Hybrid recorder', 'Continuous recorder', 'Circular and stream', 'Recorder and stream', 'Hybrid and stream', and 'Record on boot' are enabled.
- If 'Allow TSR AIR recording modes' is checked, 'Active' and 'Scheduled' are enabled.
- If 'Allow UART recording modes' is checked, 'Circular buffer + UART' and 'Recorder + UART' are enabled.
- If both 'Allow advanced recording modes' and 'Allow UART recording modes' are checked, 'Continuous recorder + UART' and 'Record on boot + UART' are enabled.

NOTE: Only Circular Buffer and Recorder modes are available for TDAS PRO, TDAS G5 and SLICE PRO Gen2 hardware. Circular Buffer + UART, Recorder + UART, Circular and stream, Recorder and stream, and Hybrid and stream modes are only supported by SLICE6 AIR DAS. Only Active and Scheduled modes are supported by TSR AIR DAS.

Circular Buffer Mode

In Circular buffer mode, the user can program the DAS to record pre- and post-trigger data. Time Zero (T=0) is marked when the trigger signal is received. An Event (T=0) signal is required to record data in Circular Buffer Mode.

Recorder Mode

Recorder mode starts recording data when a Start Record signal is received and continues for the time specified in the test setup. If a trigger signal is received some time after Start Record, this is marked as T=0.

Hybrid Recorder Mode

Hybrid recorder mode starts recording data when a Start Record signal is received and continues until the unit receives a trigger signal, after which it records for the post-trigger time specified by the test setup. The trigger signal marks Time Zero (T=0) and all data recorded is available for download.

Multiple-Event Modes

To record multiple events, choose the desired multiple-event recording mode (Circular buffer, Recorder, Hybrid recorder, Continuous recorder, Record on boot, Circular buffer + UART, Recorder + UART, Continuous recorder + UART, or Record on boot + UART). In these modes, the maximum number of events is specified, and the DAS is re-armed after each event has completed. The DAS may be disarmed at any time before the final event has been collected, but will disarm automatically if the maximum number of events specified has been reached.

Continuous Recorder Mode

The Continuous recorder and Continuous recorder + UART modes record for as long as the start button is held. The trigger event is the stop indication, and it will disarm instead of marking the event. Continuous recorder modes also support multiple event recording.

If the Record on boot checkbox is enabled, recording starts immediately when the DAS is rebooted, and it will record continuously until the next reboot or until the memory is full. It will continue to record after each reboot until either it is disarmed or the maximum number of events has been reached.

Circular and Stream Mode

SLICE6 AIR DAS only. Record on the device in Circular Buffer mode while also streaming the same information out. Information can be recorded on the DAS at a higher rate than it can be streamed out, so the streaming rate may not match the recording sample rate. Supports multiple event recording.

Recorder and Stream Mode

SLICE6 AIR DAS only. Record on the device in Recorder mode while also streaming the same information out. Information can be recorded on the DAS at a higher rate than it can be streamed out, so the streaming rate may not match the recording sample rate. Supports multiple event recording.

Hybrid and Stream Mode

SLICE6 AIR DAS only. This recording mode is a hybrid recording mode that also streams while recording. The hybrid recording portion behaves just like regular hybrid recording. Supports multiple event recording.

Active Mode

Only supported by TSR AIR DAS. Enables the TSR AIR to record as soon as it is armed, and will also arm on boot if power or the On signal are removed and then later reapplied. This mode supports recording pre- and post-event data. Time Zero (T=0) is marked when the event signal is received. The maximum pre-event data is .0512s. There are three options for this mode:

- Level triggers: Only available when “start recording with event line” is not used.
- Start recording with event line: Pre-event data is not available with this option. This is the lowest power option.
- Wake up with motion: The TSR AIR will wake up when sensing motion. Does not work when there are level triggers less than or equal to 5g.

Scheduled Mode

Only supported by TSR AIR DAS. Enables the TSR AIR to wake and record at a scheduled time (UTC) or interval (in minutes). The TSR AIR will remain in very low power mode until the scheduled time and will then arm and begin recording. Pre-event data is not available when using this mode.

UART Modes

SLICE6 AIR DAS supports single- and multiple-event Circular buffer + UART, Recorder + UART, Continuous recorder + UART, and Record on boot + UART modes. When one of these modes is used, data is also recorded on a UART channel. These data collection modes allow for simultaneous sampling from analog (bridge, IEPE, and thermocouple) sensors and recording data streaming from a UART device (ex: UART GPS). When collecting data in these modes, half of the internal flash memory is available for analog data and half is available for UART data. Note: analog sensor sample rates are limited when simultaneously recording UART data. When UART is configured for 9600bps and below, analog sample rates are limited to 30000sps. When UART is configured for 14400bps and above, analog sample rates are limited to 10000sps.

Record on Boot Mode

SLICE6 AIR DAS only. Record on the device immediately upon rebooting. Record on boot mode also supports multiple event recording (100 event maximum). Each power cycle creates an individual event. The device will not re-arm after a power cycle when either the specified number of events has been reached, or if the device was disarmed prior to powering down.

- At boot up, the system will take 30 seconds to perform diagnostics. This can be shortened by selecting the “Preserve run test diagnostics for auto-arm/streaming” option under System Settings > Test Setup Settings > Test info.
- The recorded data length depends on the time until power off via switch or hard power. When switched off, the last sample address is saved, and no extra data is padded. When powered off via hard power, the entire memory block is saved, and data is padded to fill the memory block.
- Recording will stop when the memory is full, indicated by the STS status indicator flashing red (5hz).

Auto Arm

DataPRO is also capable of configuring DAS in Auto Arm mode, which will cause the unit to arm automatically after being power cycled. This mode is useful when the unit needs to be configured before being placed in a location with limited access.

Here are the steps to use the Auto Arm mode:

1. Once the recording mode and settings (pre-/post-trigger times, test ID, etc.) are chosen, you can Auto Arm the DAS;
2. Remove power (or the ON signal);

3. Place the DAS in test location – it does not matter how long the DAS stays unpowered, it will keep the arming settings in its internal memory, ready to be configured at the next boot;
4. Reapply power (or the ON signal) – the unit will boot;
5. The unit will either arm directly or perform Diagnostics on all channels (see [Test Setups](#), page 83, for more details on how to enable the Diagnostics when using the Auto Arm mode and how to configure the delay before performing the Diagnostics);
6. Depending on the LED scheme of the DAS, the LED will indicate that the DAS is armed and ready to record data – it will still need either a Start Record or a Trigger signal to record data.

Streaming

DataPRO is capable of configuring SLICE6 AIR DAS for streaming data applications. In this mode, no data will be recorded to the internal flash memory and all data will be streamed to a third-party application for viewing and analysis. See [Appendix I: SLICE6 AIR Setup](#), page 327, for more information.

Sampling Rates

DataPRO allows collecting data from DAS configured with different sample rates in the same test. Sample rates can be set per DAS; each SLICE PRO Module can be configured with a different sample rate, each TDAS PRO Rack must have the same sample rate, each SLICE Nano/Micro stack must have the same sample rate.

SLICE and TDAS equipment support different sampling rates. Additionally, TDAS G5 DAS, TDAS PRO TOM and all SLICE DAS will record all channels even if they are not programmed, so these unused channels must be included when calculating recording time.

Number of Channels*	Maximum Sampling Rate (per channel)				SLICE6/ SLICE6 AIR
	SLICE MICRO/NANO		SLICE PRO		
	Base	Base+	SIM (Gen 2/3), DIM	TOM	
3	120,000 sps	500,000 sps	1,000,000 sps		
4				1,000,000 sps**	
6	60,000 sps	400,000 sps	1,000,000 sps		400,000 sps
9	40,000 sps	300,000 sps	1,000,000 sps		
12	30,000 sps	200,000 sps	500,000 sps		
15	24,000 sps	200,000 sps	500,000 sps		
18	20,000 sps	200,000 sps	500,000 sps		
21	17,000 sps	200,000 sps			
24	15,000 sps	200,000 sps			

* All channels are recorded even if they are not programmed.

** Records current and voltage for each channel (i.e., records 8 channels).

Number of Channels	Maximum Sampling Rate (per channel)			
	TDAS G5 DAS*	TDAS PRO SIM (16 MB)	TDAS PRO SIM (4 MB)	TDAS PRO TOM*
4				38,000 sps**
8		38,000 sps	38,000 sps	
32	100,000 sps			

* All channels are recorded even if they are not programmed.

** Records current and voltage for each channel (i.e., records 8 channels).

How to Calculate Maximum Recording Time

SLICE MICRO/NANO, SLICE PRO, SLICE 6, TDAS G5 and TDAS PRO have different data storage capacities.

	SLICE MICRO/ NANO Base	SLICE MICRO/NANO Base+, SLICE PRO SIM (Gen 2/3), SLICE6/SLICE6 AIR	SLICE PRO TOM	SLICE PRO Trig Dist
Data Capacity*	6.48 GB	15 GB	15 GB	15 GB
Samples Available**	3,240,000,000	7,500,000,000	7,500,000,000	7,500,000,000

* Running a SLICE6 AIR in a UART recording mode will reserve half the memory for recording UART data. With 15 GB of memory on a SLICE6 AIR, 7.5 GB will be reserved for UART data and 7.5 GB will be reserved for recording data from connected sensors.

** 1 sample = 2 bytes

	TDAS G5 DAS*	TDAS G5 DAS*	TDAS PRO SIM*	TDAS PRO SIM*	TDAS PRO TOM
Data Capacity	100 MB (RAM)	50 MB (RAM)	16 MB**	4 MB**	16 MB
Samples Available	50,000,000	25,000,000	8,000,000	2,000,000	8,000,000

* Contact DTS if you need help determining the capacity of your unit.

** Flexibly allocated to programmed channels only.

To determine the recording time possible, use the equation below:

Samples available

$$\frac{\text{Samples available}}{\text{Sampling rate (sps) X number of channels}} = \text{number of seconds}$$

Sampling rate (sps) X number of channels

Example 1: 10,000 sps using a 9-channel SLICE NANO/MICRO stack

$$\frac{3,240,000,000}{10,000 \times 9} = 36,000 \text{ sec (10 hours)}$$

Example 2: 25,000 sps using an 18-channel SLICE PRO SIM

$$\frac{7,500,000,000}{25,000 \times 18} = 16,667 \text{ sec (4.63 hours)}$$

Example 3: 20,000 sps using 6 channels of a 16 MB TDAS PRO SIM

$$\frac{8,000,000}{20,000 \times 6} = 66 \text{ sec}$$

SLICE Circular Buffer Limitations

Due to the nature of flash memory, SLICE systems cannot be armed in Circular Buffer mode indefinitely. To determine the maximum time available in Circular Buffer mode, use the equation below:

$$0.8 * \text{recording time} = \text{maximum time available in Circular Buffer mode}$$

Example:

$$0.8 * 16,667 \text{ sec} = 13,333.6 \text{ sec (222.227 minutes)}$$

In this example, the test must occur within 222 minutes, after which time the unit stops recording data.

Navigating DataPRO

DataPRO's user interface color-codes tabs by function. Not all tabs will be available to all users. Account Administrators can configure DataPRO to allow access to certain tabs and functions within tabs as necessary.

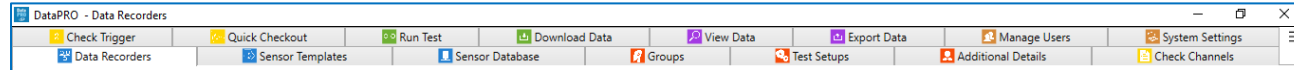

Tabs with blue icons contain Physical Hardware information:

- Data Recorders
- Sensor Templates
- Sensor Database

Tabs with orange icons contain Preparation information:

- Groups
- Test Setups
- Additional Details; Channel Codes, Customer/Engineer/Lab Details

Tabs with yellow icons perform Diagnostic routines:

- Check Channels
- Check Trigger
- Quick Checkout

Tabs with green icons perform Data Collection routines:

- Run Test/Data collection
- Download Data

Tabs with purple icons perform Data Review routines:

- View Data
- Export Data

Tabs with brown icons contain Administrative functions:

- Manage Users
- System Settings

Tab Options

Within tabs, most screens have menus along the left side (navsteps), along the top (page buttons), or both. Some screens have additional options (action buttons, radio buttons) that allow for quickly filtering tables or manipulating data. In general, proceed from top to bottom when using the navsteps; if there are no navsteps, use the page buttons. Not all navsteps or page buttons need to be completed on each menu. Use the Done button to return to the tab home screen. On most pages DataPRO will alert if changes have been made and not saved. However, it is recommended to save early and often.

Page buttons

Navsteps

Radio buttons

Action buttons

Sensors Available

Serial Number	Name	IEPE	Capacity (EU)	Units	Out Of Date	In Warning Per
2kg034	Little load cell		2,000.00	g		
2KG035	This is a sample DTS Load Cell entry		2,000.00	g		
6DXG20055-A1	Head ACX		2,000.00	g		
6DXG20055-A2	Head ACY		2,000.00	g		
6DXG20055-A3	Head ACZ		2,000.00	g		

Sensors Found

Measure Bridge	Data Recorders	Channel	IEPE	ID	Serial num
	SPE00150:SPS00331	CH-01		760000075066DD2D	BP01 (Bridge Plug 1)
	SPE00150:SPS00331	CH-02		CB000007508CEC2D	BP02 (Bridge Plug 1)
	SPE00150:SPS00331	CH-03		220000075066312D	BP03 (Bridge Plug 3)
	SPE00150:SPS00331	CH-04		No Id found	---
	SPE00150:SPS00331	CH-05		No Id found	---
	SPE00150:SPS00331	CH-06		No Id found	---
	SPE00150:SPS00331	CH-07		E70000075082312D	BP04 (Bridge Plug 4)
	SPE00150:SPS00331	CH-08		2B000007508D2A2D	BP05 (Bridge Plug 5)
	SPE00150:SPS00331	CH-09		60000007508DA22D	BP06 (Bridge Plug 6)

Up and down arrows indicate menus that can be expanded or collapsed. Required fields are indicated in red.

Collapsed menu
Expanded menu

Serial number	<input type="text"/>
Property	Axis 1
Display	
Physical	
Sensor type	Full bridge
Supported excitation	2V <input type="checkbox"/> 5V <input checked="" type="checkbox"/> 10V <input type="checkbox"/>
Sensor Offset (mV)	Check <input checked="" type="checkbox"/> Low <input type="text" value="-100.000"/> High <input type="text" value="100.000"/>
Shunt	Emulation <input type="checkbox"/> Resistance (Ω) <input type="text" value="350.00"/>
Sensor ID	<input type="text"/>
Calibration	
Calibration	Proportional to Excitation <input checked="" type="checkbox"/>
	Remove offset <input checked="" type="checkbox"/>
	Based on Output at Capacity <input type="checkbox"/>
	Non-Linear <input type="checkbox"/>
	Software zero Method
	Avg over time

Required field

When viewing test data, available channels are listed on the left side. The modification pane offers on-the-fly customizable data views, filter options and the ability to modify a data channel (These features are explained in more detail in [Review](#), page 175).

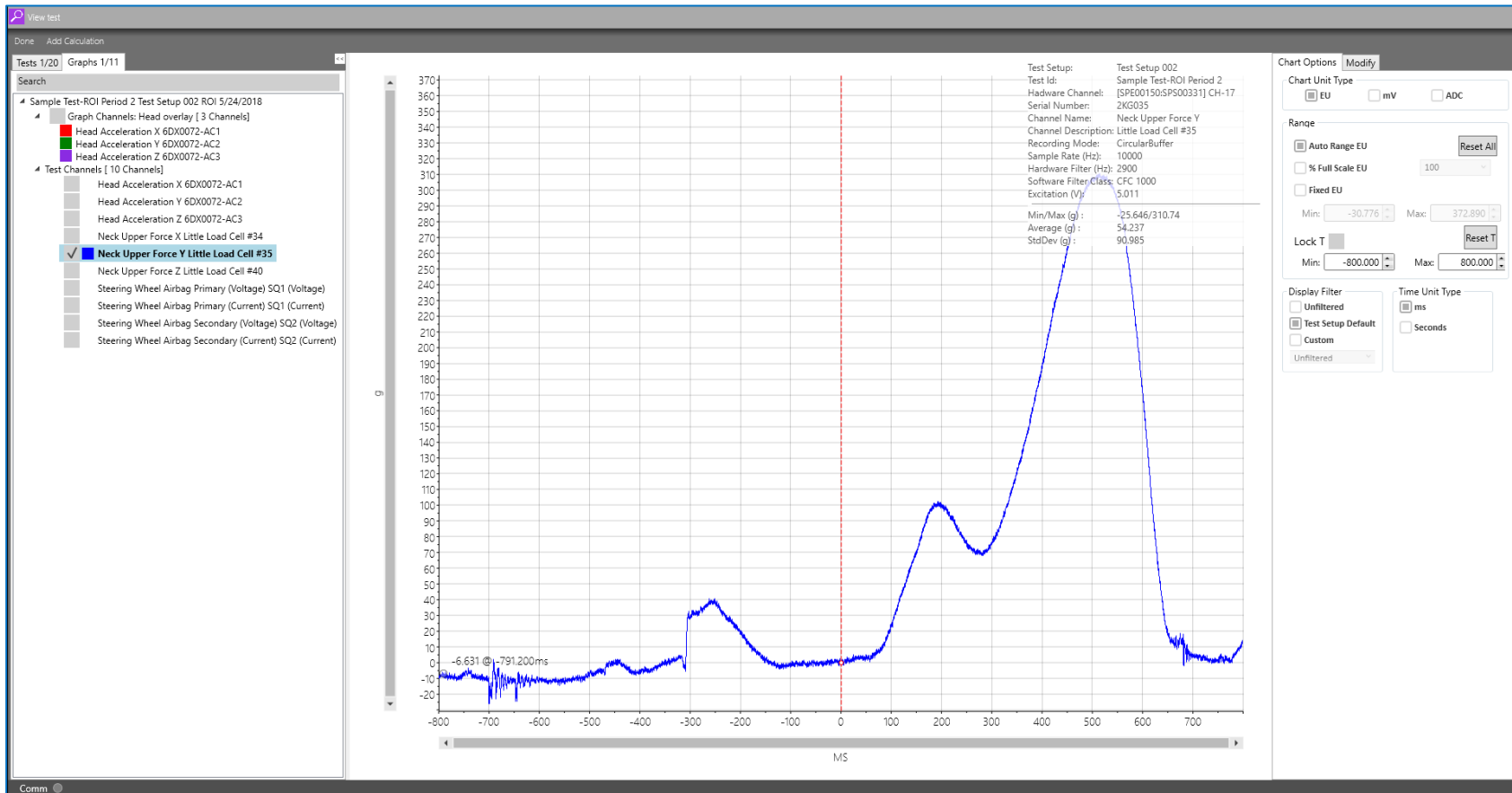

Status Bar

The status bar at the bottom of DataPRO displays various information relating to the DataPRO version and license, account details, status information, and recent actions.

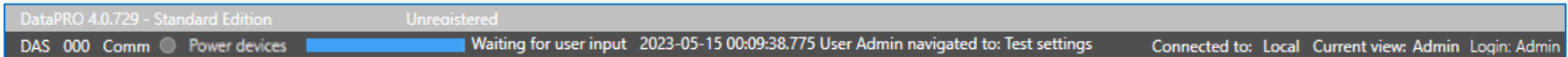

If a POWER PRO or SLICE Distributor is connected, a **Power devices** button will be available next to the **Comm** LED in the lower right. Clicking this button launches the configuration webpage where you can change device settings. For more information on the available settings, refer to the [POWER PRO User's Manual](#) or [SLICE Distributor User's Manual](#).

Hamburger Menu

The hamburger menu in the upper right of DataPRO gives you quick access to certain actions and information:

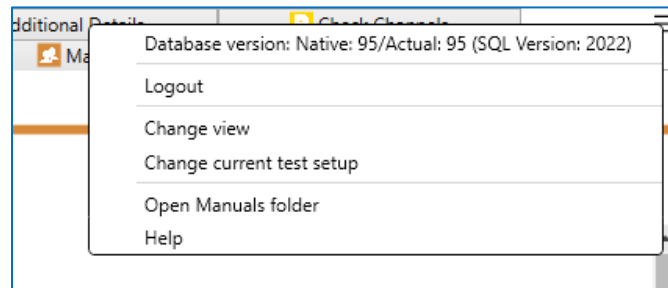

- **Database version:** Lists both the native database version which the application client will try to target if it is available, and the actual database version in use.
- **Logout:** Log out of DataPRO without closing the application.
- **Change view:** Switch the available view to that of a different user role.
- **Change current test setup:** Quickly select which test setup is the active one.
- **Open Manuals folder:** Open the folder containing product documentation.
- **Help:** Launch DataPRO help.

Quick Start

DataPRO allows for the use of ISO Codes, User Codes, or both. To select which code type to use, go to “System Settings → Channel Code Settings” and enable the appropriate options. This manual was written with only ISO Codes enabled (See <https://www.iso-mme.org/> for more information on using ISO Codes).

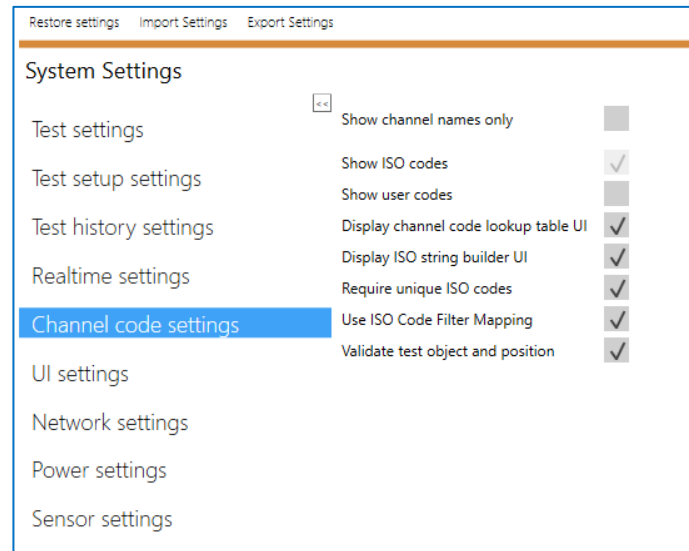

To collect data with the least amount of setup, complete the following steps:

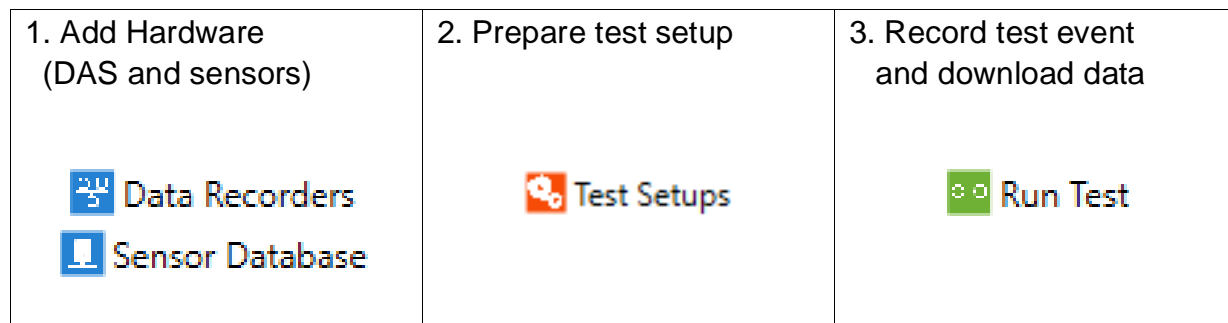

While this may be the quickest way to begin testing, DTS highly recommends implementing a documented test procedure and using the diagnostic functions available to provide the most reliable and consistent testing experience.

Physical Hardware

The tabs in the Physical Hardware group manage and maintain configurations and parameters for all DAS and sensors.

Data Recorders

- To detect (auto-discover) DAS, start at step 1.
- To update hardware configuration, go to step 8.
- To add DAS manually, go to step 9.
- To edit DAS, go to step 13.
- To delete DAS, go to step 14.
- To export DAS, go to step 15.
- To import DAS, go to step 16.
- To generate a DAS hardware usage report, go to step 18.

NOTE: Detecting DAS and updating hardware configuration can also be done from the Groups and Test Setups tabs while adding or editing groups and test setups.

Detect

1. To detect DAS, power up and connect the DAS to the PC (Windows may install a device driver to support USB communication and ask to reinstall the driver each time a SLICE Stack is connected to a different USB port):

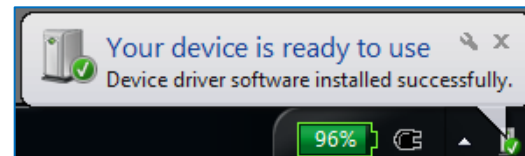
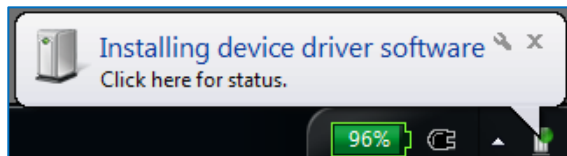

2. Select the "Data Recorders" tab:

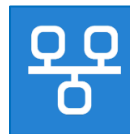

3. From the Data Recorder home screen, select “Discover Hardware” to find all connected DAS:

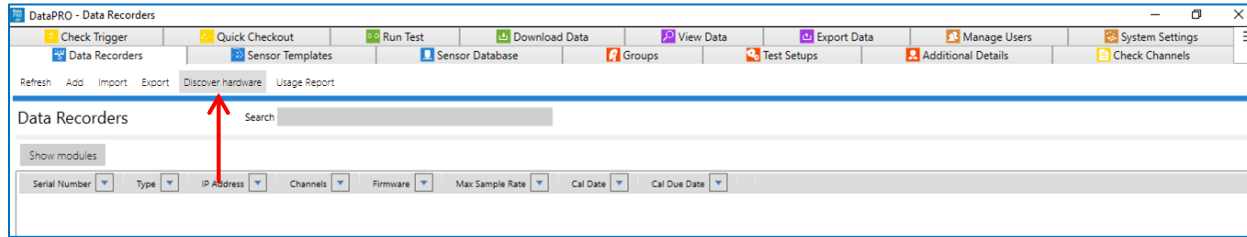

4. If IP address(es) of connected DAS is known, enter IP address(es) for Ethernet DAS and select “Add”. IP address(es) will populate the Add/Update DAS table. *Note: AutoDiscovery must be toggled off in order to enter IP addresses.*

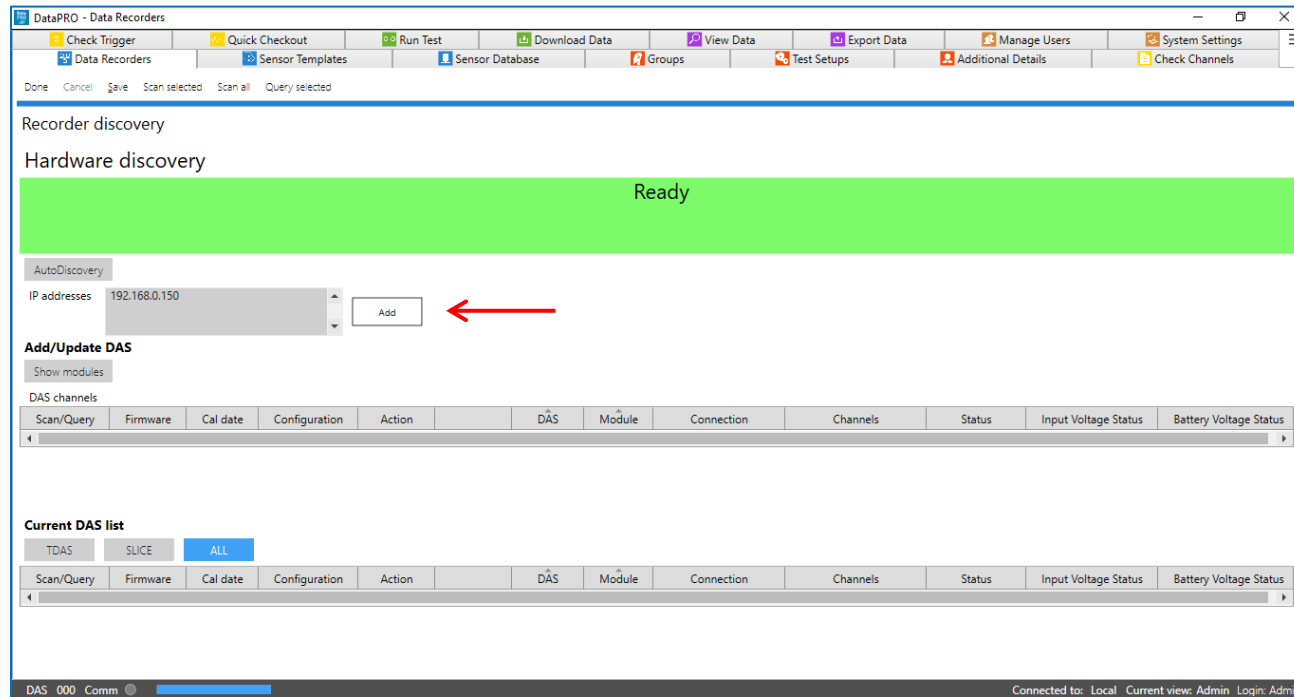

a. If IP address(es) are not known, enable AutoDiscovery to ping all available IP addresses in the compatible range.

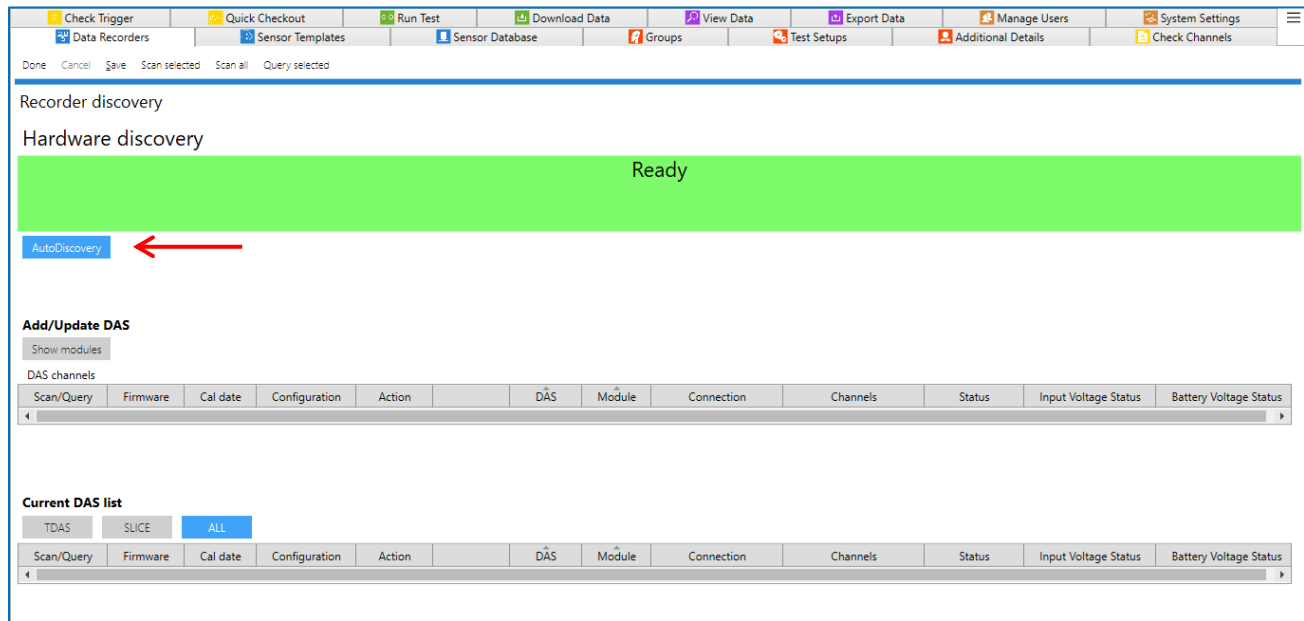

- Optionally, you may specify a range of IP addresses by including a list of start/end pairs in a file named *HWIPRanges.txt* in the *C:\DTS\DTS.Suite\<version>\DataPRO* folder, as follows:

```
192.168.1.85, 192.168.1.93
192.168.3.1, 192.168.5.99
etc.
```

- Select "Scan all" or "Scan selected" to confirm IP address(es) and to discover USB connected DAS:
 - Scan all will attempt to confirm communication with all DAS in the database, or in the compatible range if AutoDiscovery is enabled.
 - Scan selected will attempt to confirm communication only with selected DAS

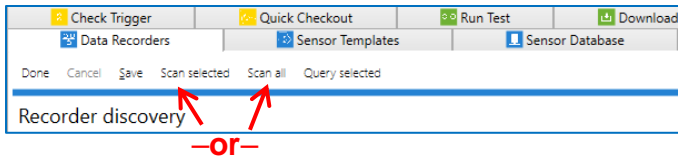

- Select “Query Selected” to establish communication and query the hardware configuration of discovered or selected DAS:

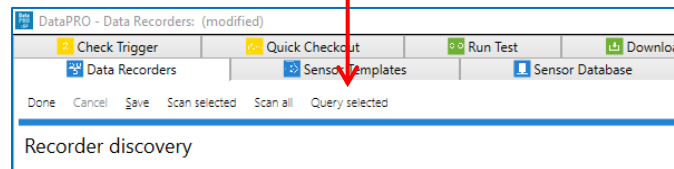

- Select “Show Modules” to display modules connected to each discovered DAS:

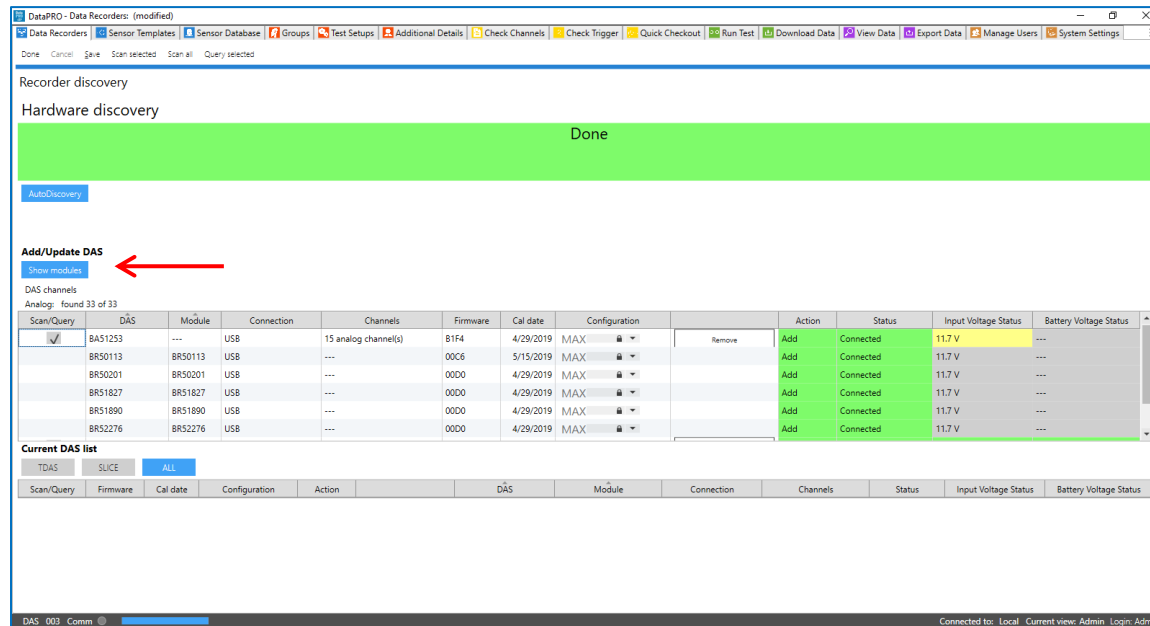

- Select “Save” to add DAS to the database:

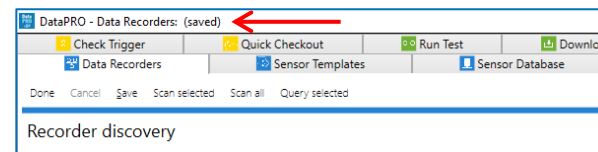
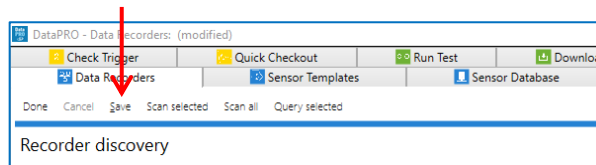

Update

- To update the configuration of DAS that has already been added to the database, select the desired DAS from the table and follow steps 6 and 7.

Add

- To add DAS manually, select “Add” from Data Recorder home screen:

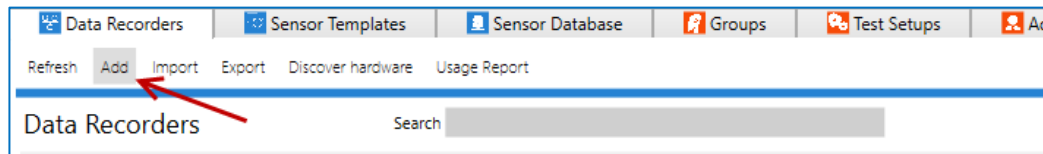

- Select DAS type from the dropdown:

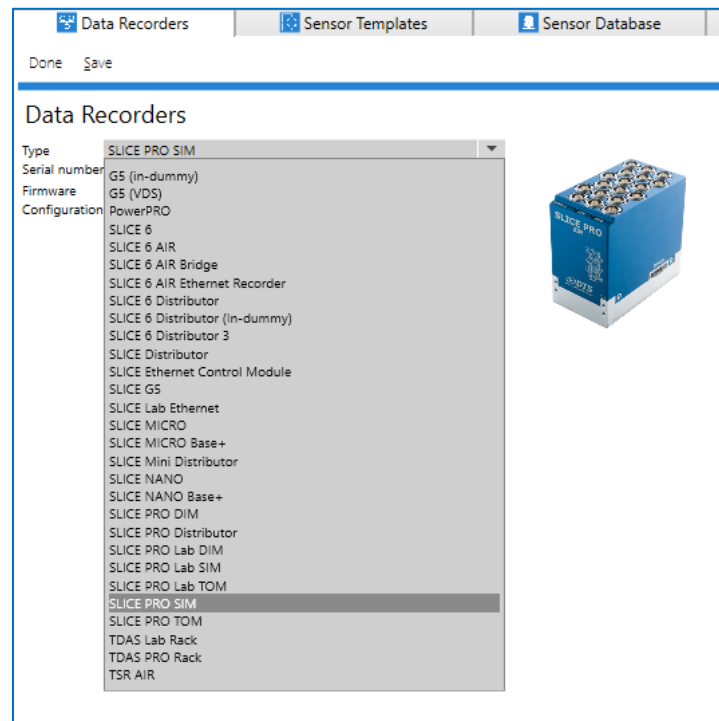

11. Select “Save” to add DAS to the database:

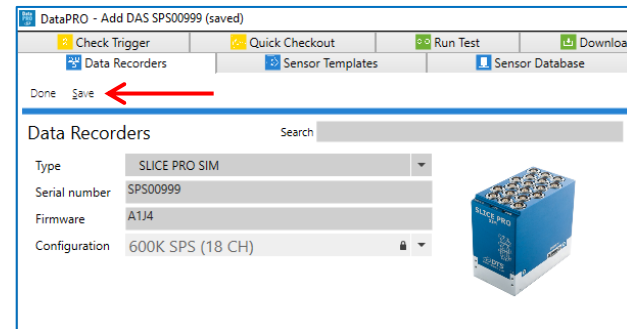
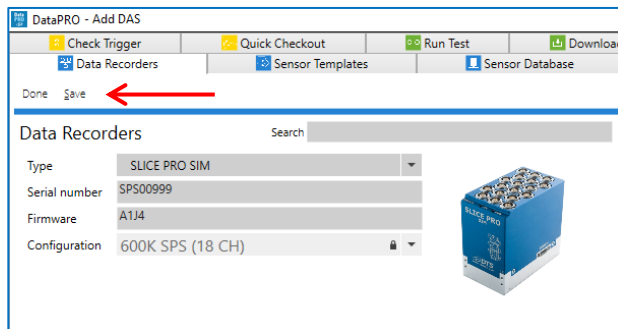

NOTE: *Firmware and calibration date (if supported by the DAS/firmware) will be updated upon establishing communication with the hardware.*

12. Select “Done” to return to the Data Recorder tab Home screen:

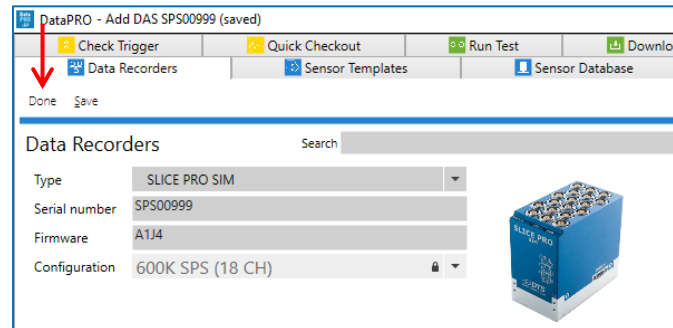

Edit

- To edit DAS information (IP address, Firmware), select the DAS from the “Data Recorders” home screen. Select “Edit” to change the information. Select “Save” to record the changes to the database.

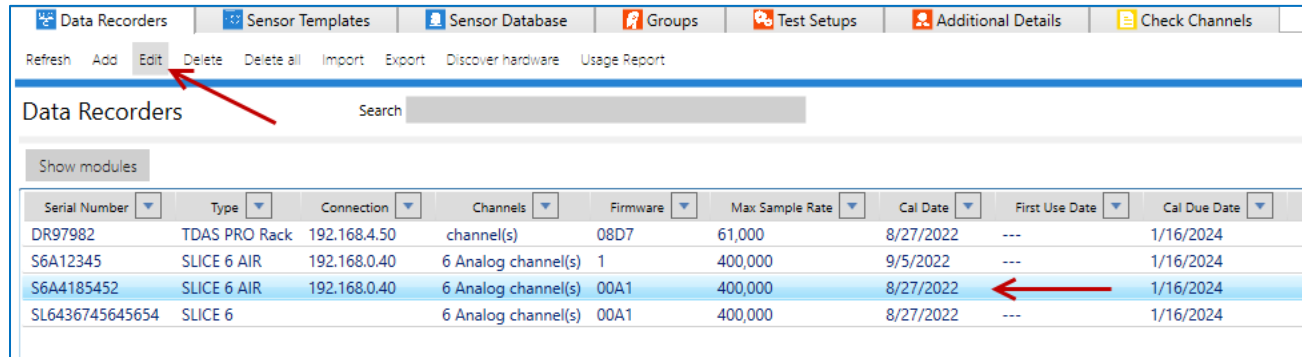

Serial Number	Type	Connection	Channels	Firmware	Max Sample Rate	Cal Date	First Use Date	Cal Due Date
DR97982	TDAS PRO Rack	192.168.4.50	channel(s)	08D7	61,000	8/27/2022	---	1/16/2024
S6A12345	SLICE 6 AIR	192.168.0.40	6 Analog channel(s)	1	400,000	9/5/2022	---	1/16/2024
S6A4185452	SLICE 6 AIR	192.168.0.40	6 Analog channel(s)	00A1	400,000	8/27/2022	---	1/16/2024
SL6436745645654	SLICE 6		6 Analog channel(s)	00A1	400,000	8/27/2022	---	1/16/2024

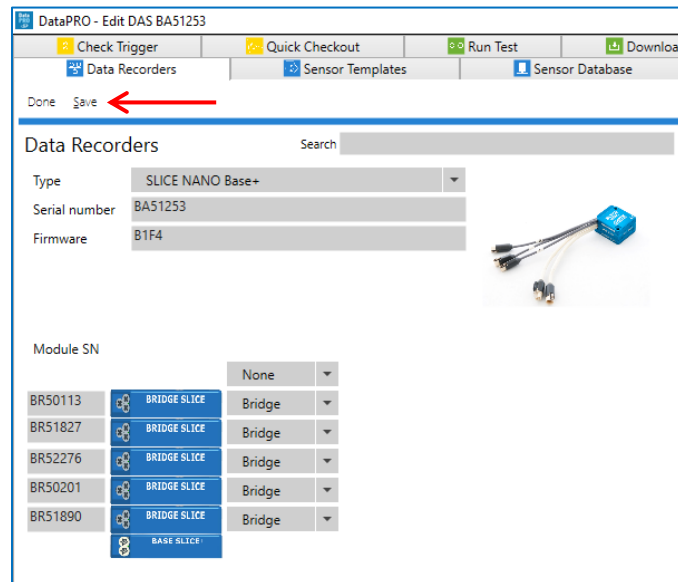

Done Save

Data Recorders

Type: SLICE NANO Base+

Serial number: BA51253

Firmware: B1F4

Module SN

Module SN	Module Name	Status
BR50113	BRIDGE SLICE	Bridge
BR51827	BRIDGE SLICE	Bridge
BR52276	BRIDGE SLICE	Bridge
BR50201	BRIDGE SLICE	Bridge
BR51890	BRIDGE SLICE	Bridge
	BASE SLICE	

Delete

14. To delete a DAS from the database, select the DAS, select “Delete” and then “Yes” to confirm:

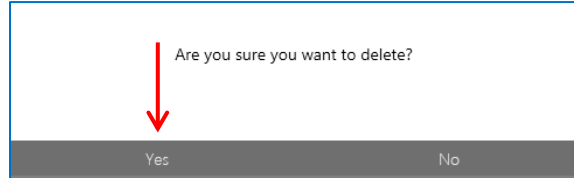
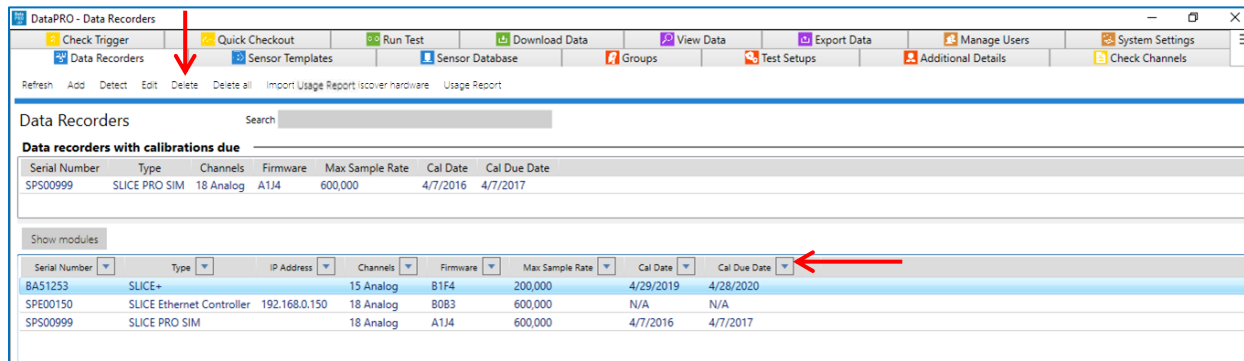

- Select and delete multiple DAS by using Shift or CTRL.
- Delete all DAS using the Delete all menu option.

Export

- To export DAS information to an XML file, select “Export”. Select one or more DAS and browse to the desired location to save the file. Enter a file name and select “Save”. Select “Export” to export the DAS, then select “Done” when finished:

The screenshots illustrate the following steps:

- Step 1:** The user clicks the **Export** button in the top menu bar of the **Data Recorders** window.
- Step 2:** The interface shows a **Waiting** state. The **Export File** field is populated with `C:\DTS\DTS.Suite\3.3.609\DataPRO\ExampleDAS.xml`. A red arrow points to the **Browse** button.
- Step 3:** The interface shows a **Done** state with a green banner. A red arrow points to the **Export** button in the top menu bar. Below the banner is a table of data recorder details.

Serial Number	IP Address	Type	Channels	Firmware	Max Sample Rate	Cal Date	First Use Date	Cal Due Date
✓ DR97982	192.168.4.50	TDAS PRO Rack	channel(s)	08D7	61,000	8/27/2022	---	1/16/2024
✓ S6A12345	192.168.0.40	SLICE 6 AIR	6 Analog channel(s)	1	400,000	9/5/2022	---	1/16/2024
✓ S6A4185452	192.168.0.40	SLICE 6 AIR	6 Analog channel(s)	00A1	400,000	8/27/2022	---	1/16/2024
✓ SL6436745645654		SLICE 6	6 Analog channel(s)	00A1	400,000	8/27/2022	---	1/16/2024

Import

16. To import DAS information from an XML file, select “Import”. Browse to select the file and then select “Import”. Select one or more DAS to import and select “Save”. Select “Done” when finished:

The screenshots illustrate the following steps:

- Clicking the **Import** button in the **Data Recorders** application.
- The application enters a **Waiting** state. The **Import File** field shows `C:\DTS\DTS.Suite\3.3.609\DataPRO\ExampleDAS.xml`. A **Browse** button is visible.
- The application enters a **Done** state. A table of imported data recorders is displayed:

Included	Serial number	Type	Number of channels	Firmware version	Max sample rate
✓	BA51253	SLICE NANO Base+	15 analog channel(s)	B1F4	200,000
✓	BR50113	Bridge	---	00C6	---
✓	BR50201	Bridge	---	00D0	---
✓	BR51827	Bridge	---	00D0	---
✓	BR51890	Bridge	---	00D0	---
✓	BR52276	Bridge	---	00D0	---
✓	SPE00150	SLICE PRO Ethernet Controller	18 analog channel(s)	80B3	---
✓	SPE00150:SPS00331	SLICE PRO SIM	18 analog channel(s)	A1Q1	600,000
✓	SPS00999	SLICE PRO SIM	18 analog channel(s)	A1J4	600,000

Refresh

17. Select Refresh to update the display with any updates made while connected to a SQL Server Database.

Hardware Usage Report

18. To generate an XML report for the DAS in the database, select “Usage Report”. The report will include DAS usage as outlined in the below table.

DAS Type	Group/Test Setup
TDAS G5	G5 module only
TDAS PRO	Rack and modules with channels assigned
SLICE Micro/Nano/IP68	Base and Bridges with channels assigned
SLICE PRO	All Modules
SLICE G5	All modules
SLICE6/SLICE6 AIR	All modules
SLICE/SLICE6/SLICE6 AIR Distributor	All modules

- a. Select Usage Report from the Data Recorder tab.

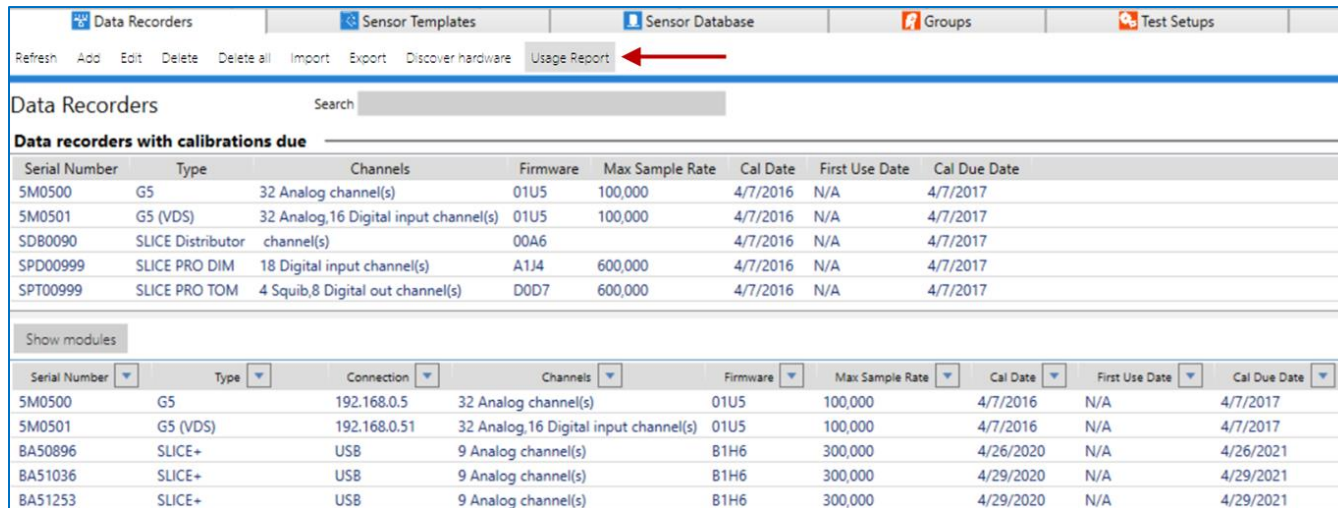

The screenshot shows the 'Data Recorders' tab selected in the top navigation bar. Below the navigation bar, the 'Usage Report' menu item is highlighted with a red arrow. The main content area displays a table of data recorders with calibrations due, and a 'Show modules' button is visible below the table.

Serial Number	Type	Channels	Firmware	Max Sample Rate	Cal Date	First Use Date	Cal Due Date
SM0500	G5	32 Analog channel(s)	01U5	100,000	4/7/2016	N/A	4/7/2017
SM0501	G5 (VDS)	32 Analog, 16 Digital input channel(s)	01U5	100,000	4/7/2016	N/A	4/7/2017
SDB0090	SLICE Distributor	channel(s)	00A6		4/7/2016	N/A	4/7/2017
SPD00999	SLICE PRO DIM	18 Digital input channel(s)	A1J4	600,000	4/7/2016	N/A	4/7/2017
SPT00999	SLICE PRO TOM	4 Squib, 8 Digital out channel(s)	D0D7	600,000	4/7/2016	N/A	4/7/2017

Serial Number	Type	Connection	Channels	Firmware	Max Sample Rate	Cal Date	First Use Date	Cal Due Date
SM0500	G5	192.168.0.5	32 Analog channel(s)	01U5	100,000	4/7/2016	N/A	4/7/2017
SM0501	G5 (VDS)	192.168.0.51	32 Analog, 16 Digital input channel(s)	01U5	100,000	4/7/2016	N/A	4/7/2017
BA50896	SLICE+	USB	9 Analog channel(s)	B1H6	300,000	4/26/2020	N/A	4/26/2021
BA51036	SLICE+	USB	9 Analog channel(s)	B1H6	300,000	4/29/2020	N/A	4/29/2021
BA51253	SLICE+	USB	9 Analog channel(s)	B1H6	300,000	4/29/2020	N/A	4/29/2021

b. Select DAS to include in the report.

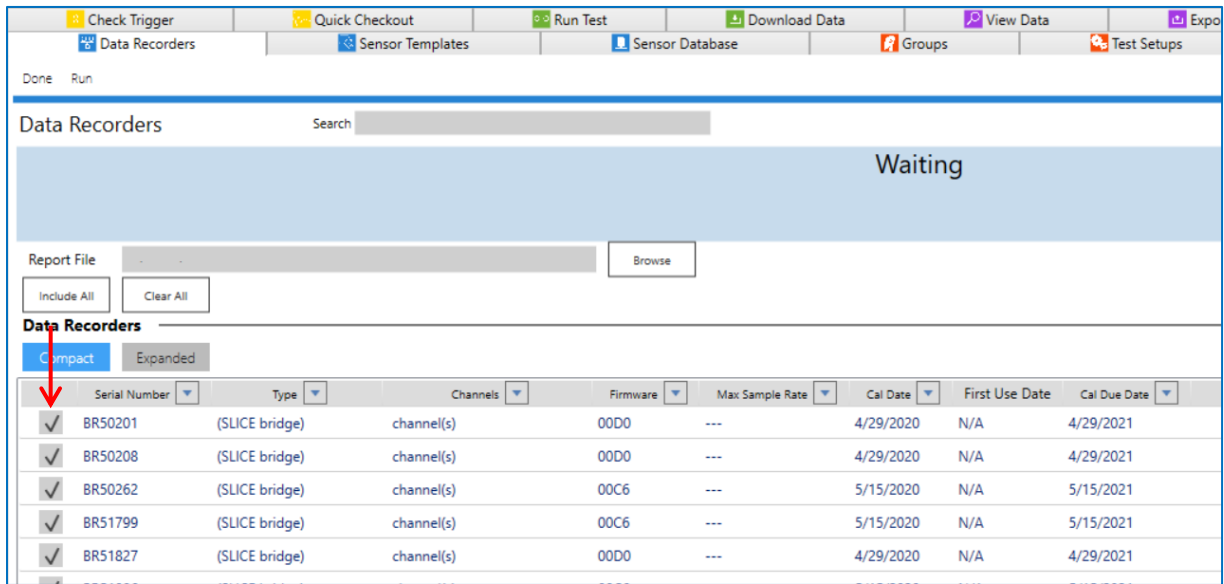

c. Navigate to/enter file path and name.

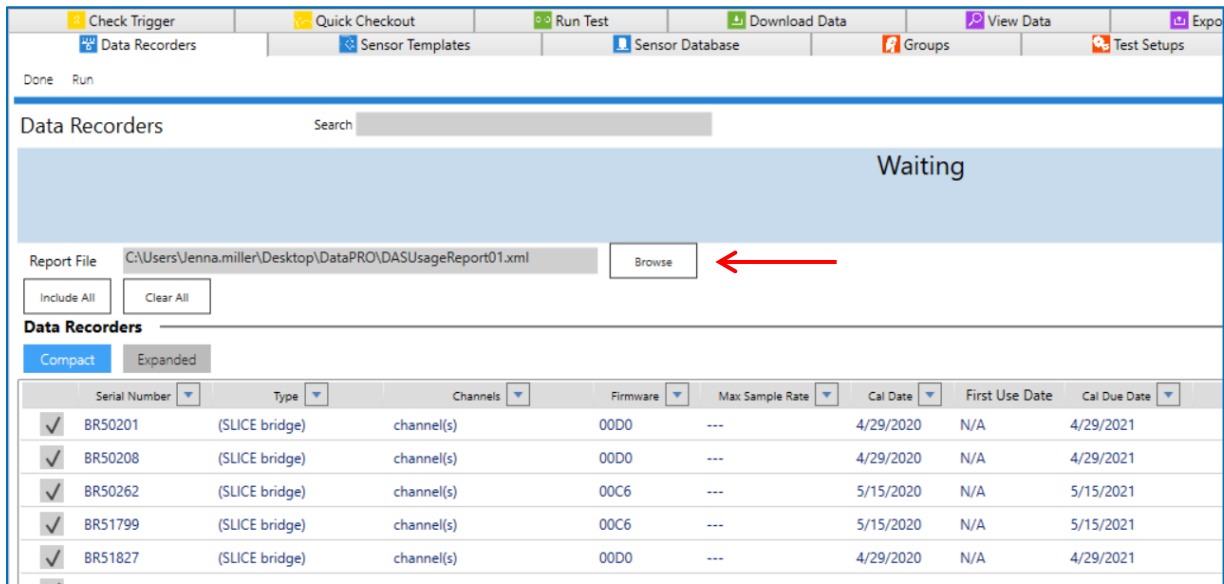

d. Select Run.

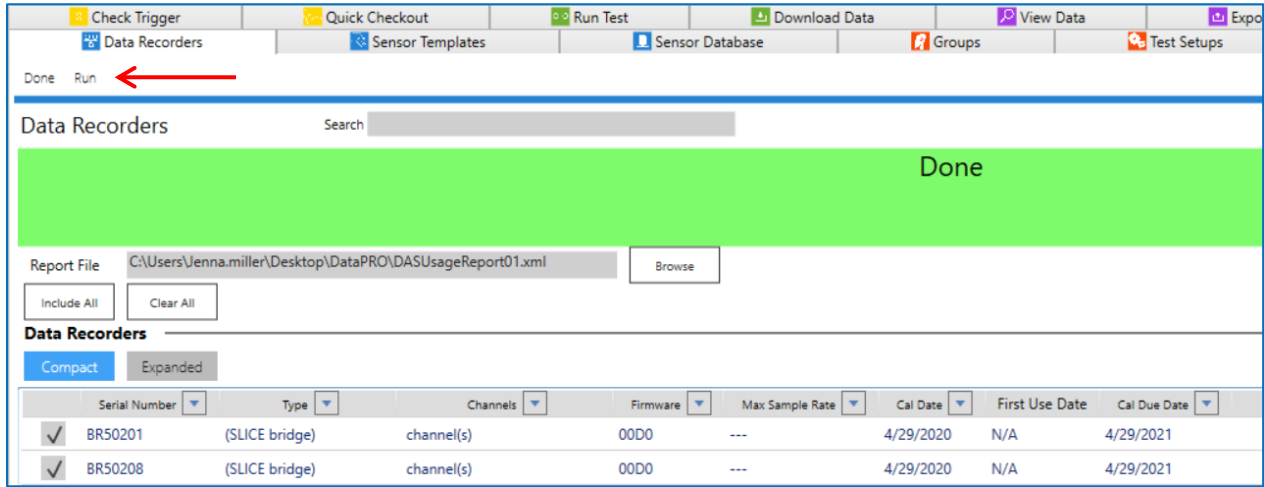

e. Excerpt from example Usage Report:

```

1  <?xml version="1.0"?>
2  <UsageReport xmlns:xsd="http://www.w3.org/2001/XMLSchema" xmlns:xsi="http://www.w3.org/2001/XMLSchema-instance">
3  <SelectedDevices>
4  <DeviceSelected>
5  <Type>DAS</Type>
6  <SerialNumber>5M0500</SerialNumber>
7  <CalDueDate>2017-04-07T16:03:30.017</CalDueDate>
8  <Groups />
9  <TestSetups />
10 </DeviceSelected>
11 <DeviceSelected>
12 <Type>DAS</Type>
13 <SerialNumber>5M0501</SerialNumber>
14 <CalDueDate>2017-04-07T16:03:30.017</CalDueDate>
15 <Groups />
16 <TestSetups />
17 </DeviceSelected>
18 <DeviceSelected>
19 <Type>DAS</Type>
20 <SerialNumber>BA50896</SerialNumber>
21 <CalDueDate>2021-04-26T00:00:00</CalDueDate>
22 <Groups />
23 <TestSetups>
24 <UsedIn>
25 <Type>Test Setup</Type>
26 <Name>Example Test Setup 2</Name>
27 </UsedIn>
28 </TestSetups>

```

19. To return to the **Quick Start** steps, go back to page 32.

Sensor Templates

Create an optional sensor template to support commonly used sensors and to speed up sensor entry and promote accuracy. A template is easily applied when creating a new sensor and the sensor specifics (S/N, calibration data, etc.) can be added or modified for each unique sensor.

- To add a sensor template, start at step 1.
- To edit a sensor template, go to step 5.
- To delete a sensor template, go to step 6.

NOTE: In the below screenshots, both ISO Codes and User Codes are enabled. To enable only ISO Codes or User Codes, see [System Settings](#), page 210.

Add

1. Select the “Sensor Templates” tab:

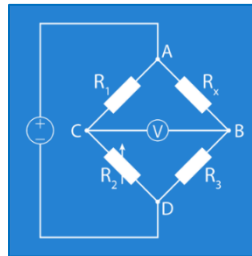

2. To add a sensor template, select “Add”:

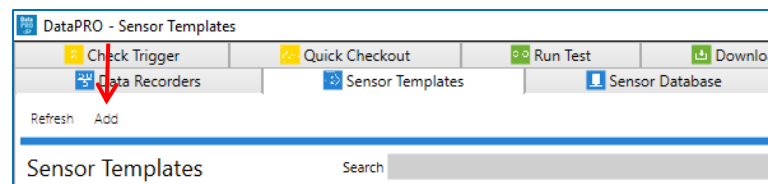

3. Only the Manufacturer and Model must be completed, however completing more fields in the template will help with sensor setup and avoid the need to revisit this information during sensor creation. It is useful to have a transducer data sheet available to complete sensor template entry:

The screenshot shows the 'Add Sensor Model' form with the following fields and values:

- Manufacturer:** (new)
- New Manufacturer Name:** (empty)
- Model:** (empty)
- Info Section:**
 - Sensor max range:** 2,400.00
 - Units:** g
 - Polarity:** +
 - Sensor type:** Full bridge
 - Non-Linear:**
 - Proportional to Excitation:**
- Display Section:**
 - ISO Code:** ??????????????????A
 - ISO Name:** (empty)
 - Default Filter:** 1650 (CFC1000)
- Physical Section:**
 - Supported excitation:** 2V 5V 10V
 - Sensor Offset:** Check
 - Low (mV): -100.000
 - High (mV): 100.000
 - Shunt:** Emulation Resistance (Ω): 350.00
 - Use AC coupling:**
- Calibration Section:**
 - Sensitivity change tolerance (%):** 5.00
 - Has been used since calibration:**
 - Initial Offset:** (empty)
 - Offset type:** None
 - Offset value:** + EU

- **Manufacturer:** Use to select from list of existing sensor manufacturers.
- **New Manufacturer Name:** Use to enter new manufacturer name if not available in above list.
- **Model:** Enter new model number/name.

- **Sensor max range:** Maximum measurable range of sensor in Engineering Units (EU).
 - **Units:** Engineering Units for the sensor.
 - **Polarity:** Negative (-) value indicates output from sensor will be inverted before converting to engineering units.
 - **Sensor Type:** Select IEPE, Quarter bridge, Half bridge or Full bridge (See [Appendix A: Common Sensor Types and Bridge Connections](#), page 249 for more details).
-
- **User Code:** Optional code used to identify measurement channel.
 - **User Name:** Optional description for measurement channel.
 - **ISO Code:** Optional code used to identify measurement channel. Can be restricted/required to 16-character length.
 - **ISO Name:** Optional description for measurement channel. See <https://www.iso-mme.org/> for more information on using ISO Codes.
 - **Default Filter:** The default frequency of a software filter to be applied to the data when viewing. This only affects the viewed data as all data stored will be collected with the hardware anti-alias filter.

NOTE: Channel full scale capacity, polarity and filter can be changed once a sensor is added to a Group or a Test Setup. Any changes to the Group or the Test Setup will not affect the settings in the sensor database.

- **Supported Excitation:** Select one or more options. DataPRO can support multiple active calibration entries for each sensor entry.
 - DataPRO will apply the first entered calibration record that is supported. For example:
 - A SLICE PRO SIM can support 2 V, 5 V and 10 V excitation.
 - An accelerometer was calibrated at 2 V, 5 V and 10 V excitation.
 - The 10 V record was entered first, followed by the 2 V record, followed by the 5 V record.
 - When supported, the 10 V record will be the calibration factor used.
 - If 10 V excitation is not supported, 2 V excitation will be applied.
 - If neither 10 V nor 2 V excitation are supported, the calibration record with 5 V excitation will be applied.
- **Sensor Offset:** Enable “Check” to measure average output during Diagnostics and compare against the low/high values entered.
- **Shunt:** Select Emulation to perform a shunt check (verify sensor impedance and signal path from sensor to analog-

to-digital converter).

- Shunt check requires accurate bridge resistance value.
- Select None or enter Bridge Resistance value of 0 to bypass shunt check.

NOTE: *Shunt checks are unreliable at over 4kΩ. If using sensors with a high bridge resistance, the shunt tolerance may have to be expanded.*

- **Use AC coupling:** Enable AC coupling for low g sensors. Only supported for TSR AIR devices.
- **Based on output at sensor max range:** Used to indicate sensor output is based on the capacity of the sensor. If enabled, capacity of sensor must be entered.
- **Capacity (EU):** Capacity of sensor in engineering units.
- **Initial Offset:** Used to indicate the EU that should be offset by a constant value to account for the starting point or value of the sensor. Can be entered as either EU or EU @ mV.
 - Select EU, EU at mV, LHS, RHS, or Frontal to define the offset type. Select Offset type in Parameters navstep when configuring a Group or Test Setup.

NOTE: *Use the plus (+) sign to add additional calibration entries for different excitation voltages.*

4. Select “Save” to record sensor template to database:

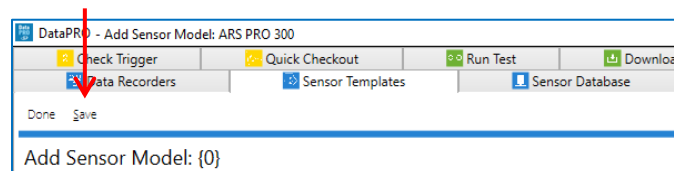

Edit

5. To edit a sensor template, select the sensor template from the list. Select “Edit” to change the information. Select “Save” to record the changes to the database:

DataPRO - Sensor Templates

Check Trigger Quick Checkout Run Test Download Data View Data Export D

Data Records Sensor Templates Sensor Database Groups Test Setups

Refresh Add Edit Delete

Sensor Templates Search

Manufacturer	Model	Sensor max range (EU)
DTS	ARS PRO 300	
DTS	ARS PRO 1500	

Delete

6. To delete a sensor template from the database, select the sensor template, select “Delete” and then “Yes” to confirm:

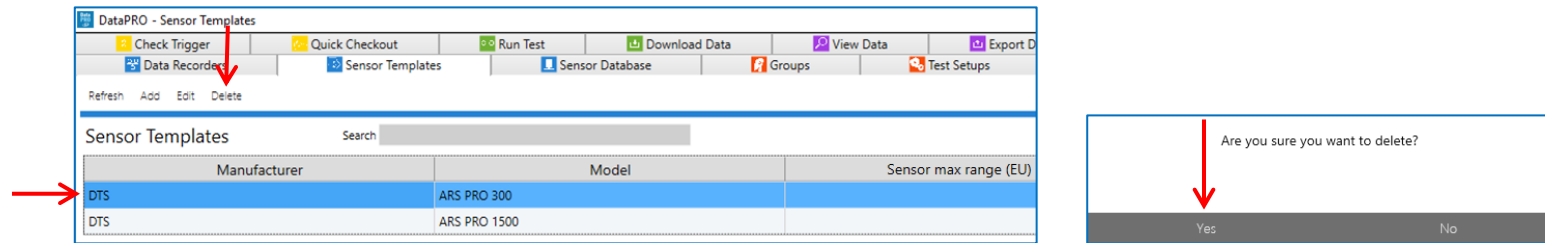

7. To return to the Quick Start steps, go back to page 32.

Sensor Database

- To import an existing database (DataPRO *.xml, SLICEWare *.xml, TDAS Control CSV or SIF files, EQX (.e2x), or TDAS Manager CSV) start at step 1.
- To add sensors manually, go to step 7.
- To edit sensors, go to step 10.
- To export sensors, go to step 11.
- To delete sensors, go to step 13.

Sensors in the Sensor Database will be shaded based on their calibration status. Sensors shaded orange have a calibration due date that is within the Warning Period; Sample Sensor 1 in below image. Sensors that are shaded red have a calibration that is past due; Sample Sensor 2 in below image. See [System Settings](#), page 210, for more information on Sensor Calibration Policies.

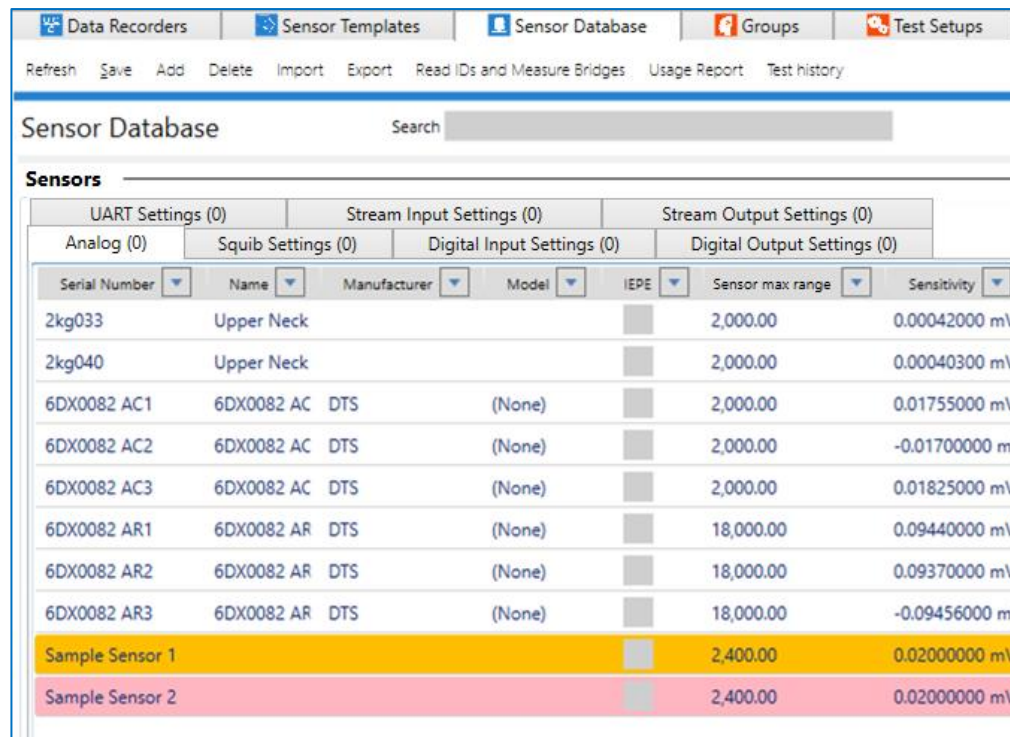

The screenshot shows the 'Sensor Database' interface with a search bar and a table of sensors. The table has columns for Serial Number, Name, Manufacturer, Model, IEPE, Sensor max range, and Sensitivity. Two sensors are highlighted: 'Sample Sensor 1' (orange) and 'Sample Sensor 2' (red).

Serial Number	Name	Manufacturer	Model	IEPE	Sensor max range	Sensitivity
2kg033	Upper Neck				2,000.00	0.00042000 mV
2kg040	Upper Neck				2,000.00	0.00040300 mV
6DX0082 AC1	6DX0082 AC	DTS	(None)		2,000.00	0.01755000 mV
6DX0082 AC2	6DX0082 AC	DTS	(None)		2,000.00	-0.01700000 mV
6DX0082 AC3	6DX0082 AC	DTS	(None)		2,000.00	0.01825000 mV
6DX0082 AR1	6DX0082 AR	DTS	(None)		18,000.00	0.09440000 mV
6DX0082 AR2	6DX0082 AR	DTS	(None)		18,000.00	0.09370000 mV
6DX0082 AR3	6DX0082 AR	DTS	(None)		18,000.00	-0.09456000 mV
Sample Sensor 1					2,400.00	0.02000000 mV
Sample Sensor 2					2,400.00	0.02000000 mV

Import

1. Select the “Sensor Database” tab:



2. Select “Import” from the menu:

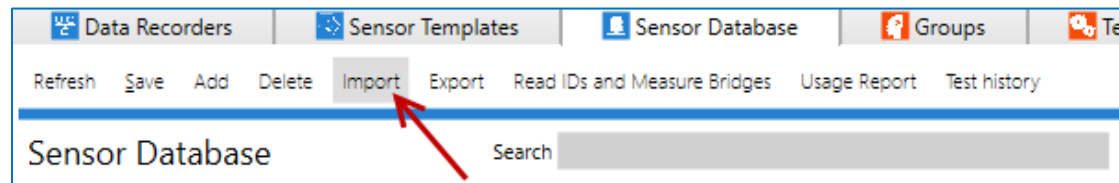

3. Select database format and browse to select the file to import. Select “Open” to continue:

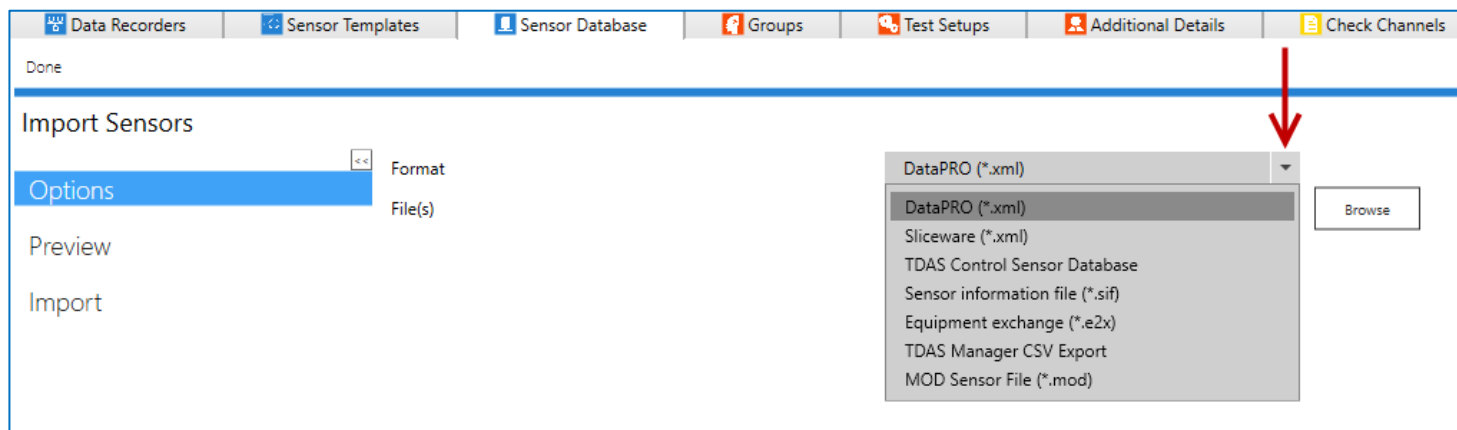

4. The **Preview** navstep lists the sensors available for import (Other import options such as Models may be available to include or remove from the import):

The screenshot shows the 'Import Sensors' window with the 'Preview' tab selected. The window title is 'Done' and the main title is 'Import Sensors'. Below the title, there are navigation options: 'Options', 'Preview' (selected), and 'Import'. The main content area shows a table of sensors with the following columns: 'Included', 'Serial number', 'Name', 'Manufacturer', 'Model', 'IEPE', 'Sensor max range (EU)', 'Sensitivity', 'Resistance (Ω)', and 'Excitati'. The table contains 8 rows of sensor data, all with 'Included' checked. Below the table, there are expandable sections for 'Models', 'Sensor groups', and 'Test Setups'.

Included	Serial number	Name	Manufacturer	Model	IEPE	Sensor max range (EU)	Sensitivity	Resistance (Ω)	Excitati
<input checked="" type="checkbox"/>	17089949	17089949	Humanetics	String Pot	<input type="checkbox"/>	36.00	23.19600000 mV/V/EU (5V)	350.00	5.0
<input checked="" type="checkbox"/>	17100383	17100383	Humanetics	String Pot	<input type="checkbox"/>	36.00	23.23460000 mV/V/EU (5V)	350.00	5.0
<input checked="" type="checkbox"/>	6DX05046-AC1		unknown		<input type="checkbox"/>	1,000.00	1.01474000 mV/V/EU (5V)	3,024.00	5.0
<input checked="" type="checkbox"/>	6DX05046-AC2		unknown		<input type="checkbox"/>	1,000.00	-1.01442000 mV/V/EU (5V)	3,024.00	5.0
<input checked="" type="checkbox"/>	6DX05046-AC3		unknown		<input type="checkbox"/>	1,000.00	1.01393000 mV/V/EU (5V)	3,024.00	5.0
<input checked="" type="checkbox"/>	6DX05046-ARS1		unknown		<input type="checkbox"/>	1,000.00	1.19990000 mV/EU	3,024.00	5.0
<input checked="" type="checkbox"/>	6DX05046-ARS2		unknown		<input type="checkbox"/>	1,000.00	1.22330000 mV/EU	3,024.00	5.0
<input checked="" type="checkbox"/>	6DX05046-ARS3		unknown		<input type="checkbox"/>	1,000.00	-1.19810000 mV/EU	3,024.00	5.0

NOTE: Sensors with critical exceptions (including no excitation, no calibration record, no sensitivity, duplicate EID) will not be imported.

5. Select sensors to import and select **Import** navstep:

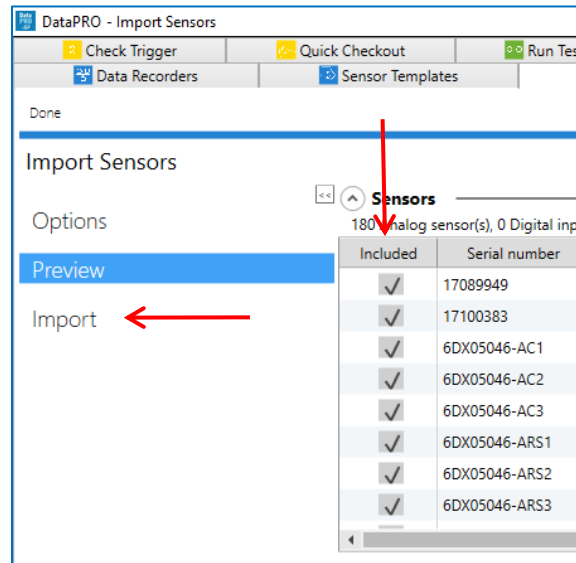

6. Select “Done” to return to the sensor table or “Import another” to continue (back to step 3):

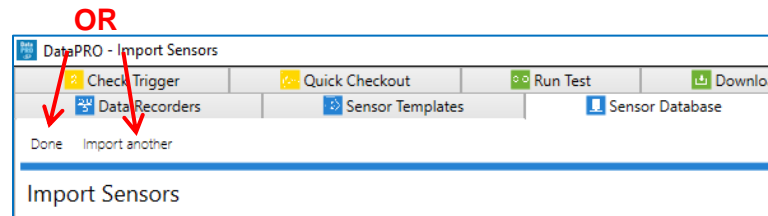

NOTE: Sensors can also be imported from a CSV file using the command line. See [Appendix B: Sensor Database Import](#), page 262, for more information on this option.

Add

7. Select “Add” to add a sensor manually:

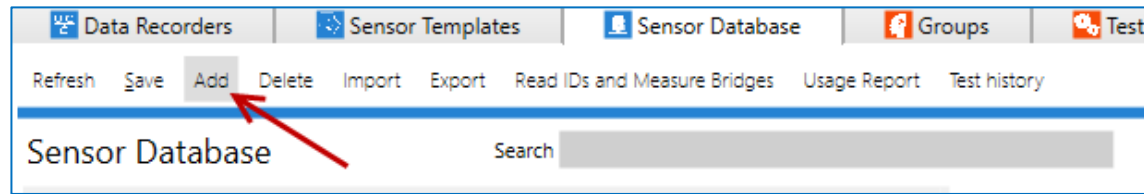

- a. Only fields noted below as Required must be completed, however having correct information in the sensor database is critical to ensuring the accuracy of collected data. It is useful to have calibration documentation available to complete sensor entry.
- b. Generic sensor fields are completed if using a Sensor Template. Some generic sensor fields are optional, but all unique sensor fields must be completed in the sensor database (Refer to [Sensor Templates](#), page 46, for generic sensor fields).

Analog channel type:

- **Assembly:** Optional field used to link sensors together. This allows sensors that are not in a Test Setup, but still part of a destructive test to have their usage counted.
- **Serial Number (Required):** Used to identify the sensor; each sensor serial number must be unique. The default display of the sensor database is sorted by sensor serial number.
- **Name:** Used as a secondary identifier of the sensor.
- **Bypass AAF:** Enable to bypass/remove the hardware anti-alias filter (AAF) (Not available for all DAS types).
- **Tags:** Used for Meter Mode display in Realtime. See [Check Channels](#), page 128, for more information on using Meter Mode display.
- **Unipolar:** Used to indicate that a sensor's output is 0 → Sensor max range, not +/- Sensor max range.
- **User Value 1, 2, 3:** Additional descriptor fields for sensors.
 - If enabled, these fields are also available in Groups and Test Setups.
 - Values entered will be included in the *.dts export.
- **Sensor ID:** Unique 16-character sensor identifier. No sensor ID may be associated with more than one active sensor at a time.
- **Last Calibration Date (Required):** Date sensor was last calibrated.

- **Non-Linear:** Used to indicate a sensor's output is not linear and will use an IR-TRACC or Cubic Polynomial equation for the sensitivity. A non-linear sensor can have an additional linear sensitivity value entered. This can be collected as a separate channel.
- **Proportional to Excitation:** Used to indicate sensor output is proportional to applied excitation.
 - If selected, actual excitation voltage applied will be used in calculating EU values.
 - If not selected, desired excitation voltage (2 V, 5 V, 10 V) will be used in calculating EU values.
- **Valid for excitation:** If "Proportional to Excitation" is selected the excitation voltage for which the sensitivity is valid must be selected.
- **Sensitivity (Required):** Enter nominal sensitivity value for the sensor type, select appropriate sensitivity units and excitation voltage.
- **Sensitivity Units:** Select mV/V/EU or mV/EU based on sensitivity value entered.
- **Remove offset:** Enable to attempt to zero ADC offset measured during diagnostics. This option is not available for all sensor types, notably non-linear sensors.
- **Software zero method:** The type of post-download software zeroing to perform before displaying engineering units.
 - **Average over time:** Used in conjunction with Start (sec)/End (sec), the average EU value during the defined window will be used to zero the collected data. The Start/End window must be included in the collected data. If using a window pre-T=0, the recording time specified in the Test Setup must include this time window.
 - **Diagnostic level:** The Zero Measured Output (ZMO) of the sensor during diagnostics will be used to set the EU zero of the downloaded data.
 - **Absolute zero:** For SLICE hardware, the actual recorded input will not be adjusted or compensated for zero level. This setting can be used to show the actual mV offset. An example may be to record a logic level signal and see the actual on/off state. For TDAS and SLICE PRO hardware, a calibrated signal of 0mV is directly injected and measured to be removed via software.
- **Calibration Interval:** Number of days in each valid calibration cycle.
- **Sensitivity change tolerance (%):** Used to require sensor inspection if the sensitivity value deviates more than the allowed tolerance. Defaults to 5%. Only visible when [System Settings](#) > [Sensor Settings](#) > Sensor Calibration Policies > **Inspect before use** is checked.
- **Has been used since calibration:** If manually entering a First Use Date (see below), check this box to indicate that the sensor has been used since it was last calibrated. This option is only available when [System Settings](#) > [Sensor Settings](#) > Sensor Calibration Policies > **Calibration interval starts after sensor's first use** is checked.

- **First use date:** You can enter the First Use Date for a sensor manually, or let it populate automatically when a destructive test (see Run Test, page 148) is run.
- **Usage count:** The number of times this sensor has been used. Only visible when [System Settings](#) > [Sensor Settings](#) > Sensor calibration policies > **Do not allow data collection if sensor is overused** is enabled.
- **Maximum usage:** The maximum number of times this sensor can be used. Only visible when [System Settings](#) > [Sensor Settings](#) > Sensor calibration policies > **Do not allow data collection if sensor is overused** is enabled.
- **Documents:** Link to calibration (or other) documents.
- **Calibration note:** Allows users to add a calibration note when adding a calibration history. The note will be shown in the history after saving.

NOTE: DataPRO stores the link, not the document. If the document is moved, DataPRO will not be able to retrieve it to view.

- **Calibration History:** This will populate when the sensor is saved as it is updated.

Digital Input channel type:

- **Name:** Used as a primary identifier of a Digital Input sensor.
- **Mode:** How the signal will be generated.
 - Transition Low-to-High
 - Transition High-to-Low
 - Contact Closure Normally Open
 - Contact Closure Normally Closed
- **Default/Active value:** The expected values for the Digital Input signal in a default/rest state and the active/signaled state.
- **Sensor ID:** Unique 16-character sensor identifier. No ID may be associated with more than one active sensor at a time.
- **Tags:** Used for Meter Mode display in Realtime. See [Check Channels](#), page 128, for more information on using Meter Mode display.

Squib channel type:

- **Name:** Used as a primary identifier of a Squib sensor.
- **Define delay in test:** If enabled, the delay time can only be defined in a Test Setup.

- **Delay (ms):** Time after T=0 for squib to fire.
- **Limit Duration:** Yes/No
- **Duration:** If enabled, time limit for signal sent to squib.
- **Low/High tolerance:** Min/Max allowable resistance values for squib.
- **Firing Mode:** How the signal will be generated.
 - Capacitor Discharge
 - Constant Current
- **Sensor ID:** Unique 16-character sensor identifier. No ID may be associated with more than one active sensor at a time.
- **Tags:** Used for Meter Mode display in Realtime. See [Check Channels](#), page 128, for more information on using Meter Mode display.

Digital Output channel type:

- **Name:** Used as a primary identifier of a Digital Output sensor.
- **Mode:** How the signal will be generated.
 - Five Volt Low-to-High Transition
 - Five Volt High-to-Low Transition
 - Contact Closure Normally Open
 - Contact Closure Normally Closed
- **Delay (ms):** Time after T=0 for signal to be sent.
- **Limit Duration:** Yes/No
- **Duration:** If enabled, time limit for signal sent to Digital Output.
- **Tags:** Used for Meter Mode display in Realtime. See [Check Channels](#), page 128, for more information on using Meter Mode display.

UART channel type:

- **Name:** Used as a primary identifier of a UART device.
- **Baud rate:** Rate that information is transferred, in bits per second.
- **Data bits:** Number of bits used to represent device commands, readings, or error messages. Note: Most serial ports use between 5 and 8 data bits. Binary data is typically transmitted as 8 bits.
- **Stop bits:** Number of bits used to indicate the end of a byte (1, 1.5, or 2).
- **Parity:** Parity bit setting used to determine transmission errors (None, Odd, Even, Mark, or Space).

- **Data format:** The format in which data should be stored (Binary, Text, or National Marine Electronics Association [NMEA]). UART data is downloaded in the Download All step of Run Test. Only recording modes which include UART will download UART data.

Stream Input channel type:

- **Name:** Used as a primary identifier of a Stream Input ethernet listening device.
- **UDP address:** Location that UDP packets should be received on. This can be a broadcast address or an IPv4 address and port on the listening device itself.

Stream Output channel type:

- **Name:** Used as a primary identifier of a Stream Output sensor like a SLICE 6 air.
- **Stream profile:** Format of the stream. Additional fields will be configurable based on the selected format.
 - Ch10 Analog Time Format 2
 - Ch10 128bit PCM Time Format 2

The following additional stream profiles will be available if Use advanced streaming profiles is enabled in System Settings -> Sensor Settings:

- Ch10 Analog
- Ch10 128bit PCM
- TmNS 144bit PCM
- TmNS Supercom (4xADCscan) PCM
- IENA Positional Message Format
- DTS Reserved
- ADC-to-UART stream
- **UDP address:** Address to which UDP packets will be streamed. This can be a broadcast or IPv4 address.
- **Time channel id:** Numeric id of a time channel for streaming profiles that contain a time channel (CH10).
- **Data channel id:** Numeric id of an ADC data channel for streaming profiles that contain a data channel (CH10).
- **TmNS config:** Additional configuration options for TmNS. Contact DTS for more information and help.
- **IRIG time packet interval (ms):** Interval at which time packets should be sent (default 500ms). Check the On box to enable the time packet interval.
- **Subframe Id:** Package id sent over in stream packets.
- **Message Id:** Message id sent over in stream packets.
- **Minor per major:** Number of minor frames per major frame in packets (default 60).
- **TMATS port:** Allows sending TMATS (Telemetry Attributes Transfer Standard) on a separate port (can be

same port). Only used in TMNS; CH10 modes always send on the same port.

- **TMATS interval (ms)**: Interval between sending TMATS information, for streaming modes which support it. (default 1000ms). Check the On box to enable the TMATS interval.
- **Source port**: IENA source port device will stream from.
- **IENA key**: Key id in IENA packets.

8. See [Appendix A: Common Sensor Types and Bridge Connections](#), page 249, for more information on entering common sensor types.

9. If needed, check or verify additional options for **Broken**, **Do not use**, or **Inspect before use**.

The screenshot shows a configuration form for a sensor. At the top, there are three checkboxes: 'Broken', 'Do not use', and 'Inspect before use', all of which are currently unchecked. To the right of these checkboxes is a button labeled 'Approve sensor for use'. Below the checkboxes are five input fields: 'Channel type' (with a dropdown arrow and the value 'Analog'), 'Manufacturer', 'Model', 'Assembly', and 'Serial number'. The 'Serial number' field is highlighted with a red border. At the bottom left of the form is an 'Info' icon and label.

- **Broken** or **Do not use** sensors are unavailable for use and can not be configured while marked as broken or do not use.
- **Inspect before use** is a read-only field that indicates an analog sensor needs inspection because its sensitivity value is deviated from the factory sensitivity value based on the specified Sensitivity change tolerance (%) field. This checkbox will be checked automatically if required based on the calibration record when saving changes to the sensor, and the user will be warned about the need for inspection. Once the sensor is manually inspected and approved, the box can be cleared by clicking the **Approve sensor for use** button. The checkbox can also be reset by entering any sensitivity once the sensor is flagged for inspection. Sensors marked as Inspect before use will be flagged in the sensor database and Channels/Test Setup, and the user will get a warning on running the test setup and cannot run the test.

10. Select "Save" to record sensor to database:

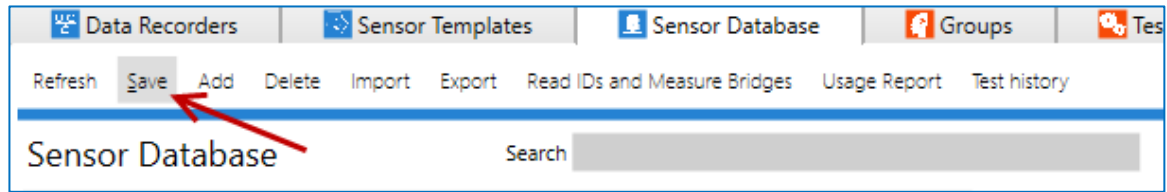

Edit

- To edit a sensor, select the sensor from the list. Edit the information on the right side of the screen (see step 7). Select “Save” (step 9) to record the changes to the database:

The screenshot shows the DataPRO v3.3.770 interface. The title bar indicates "DataPRO v3.3.770 - Edit: 2kg033 (modified)". A red arrow points to the word "modified" in the title bar, with a note: "modified" = sensor has been changed but not saved. The main window is divided into two panes. The left pane, titled "Sensor Database", contains a table of sensors. The right pane, titled "Info", shows the configuration for the selected sensor, 2kg033. The "Info" pane is highlighted with a red box. The "Sensors" table has the following data:

Serial Number	Name	Manufacturer	Model	IEPE	Sensor max range	Sensitivity	Resistance (Ω)	Excitation (V)
2kg033	Upper Neck				2,000.00	0.00042000 mV/V/EU	350	5
2kg040	Upper Neck				2,000.00	0.00040300 mV/V/EU	350	5
6DX0082 AC1	6DX0082 AC1	DTS			2,000.00	0.01755000 mV/V/EU	350	5
6DX0082 AC2	6DX0082 AC2	DTS			2,000.00	-0.01700000 mV/V/EU	350	5
6DX0082 AC3	6DX0082 AC3	DTS			2,000.00	0.01825000 mV/V/EU	350	5
6DX0082 AR1	6DX0082 AR1	DTS			18,000.00	0.09440000 mV/V/EU	350	5
6DX0082 AR2	6DX0082 AR2	DTS			18,000.00	0.09370000 mV/V/EU	350	5
6DX0082 AR3	6DX0082 AR3	DTS			18,000.00	-0.09456000 mV/V/EU	350	5
Sample Sensor 1					2,400.00	0.02000000 mV/V/EU	350	5
Sample Sensor 2					2,400.00	0.02000000 mV/V/EU	350	5

The "Info" panel for sensor 2kg033 shows the following settings:

- Sensor max range: 2,400.00
- Units: g
- Polarity: +
- Sensor type: Full bridge
- Last Calibration Date: Select a date (15)
- Non-Linear:
- Sensitivity Details:
 - Proportional to Excitation:
 - Sensitivity: 0.00000000
 - Sensitivity Units: mV/EU
- Supported excitation: 2V 5V 10V
- Sensor Offset: Check Low (mV): -100.000

- Different sensor types are managed using separate sensor tabs.
- Select the appropriate sensor tab to view and modify parameters for those sensor types.

NOTE: If multiple users are modifying the sensor database, select “Refresh” to get the latest sensor settings.

This close-up screenshot shows the toolbar of the Sensor Database. The "Refresh" button is highlighted with a red arrow. The toolbar also includes buttons for "Save", "Add", "Delete", "Import", "Export", "Read IDs and Measure Bridges", "Usage Report", and "Test history".

Export

12. To export sensor information, select “Export”:

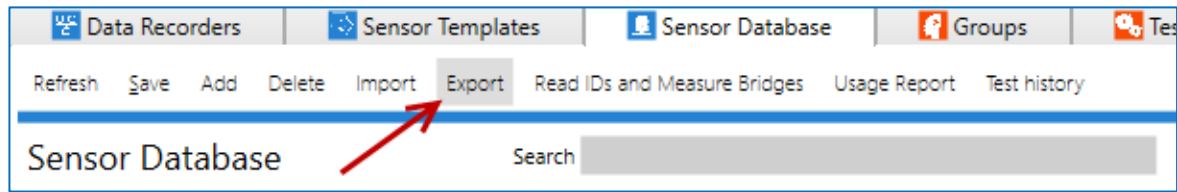

13. Select export format and browse to the desired location to save the file. Supported export file types include: DataPRO XML, SliceWare XML, TDAS Control Sensor Database, or EQX v1.5. (If exporting to TDAS Control Sensor Database format, enable “Export only TDC compatible sensors” to export only sensors compatible with TDAS Control). Browse to the desired location to save database file, and modify the export file name if desired (The default location is *C:\DTS\DTS.Suite\3.0.311\SensorDatabase*). Select the sensors to include in the export. Select “Export” to save. Select “Done” when finished.

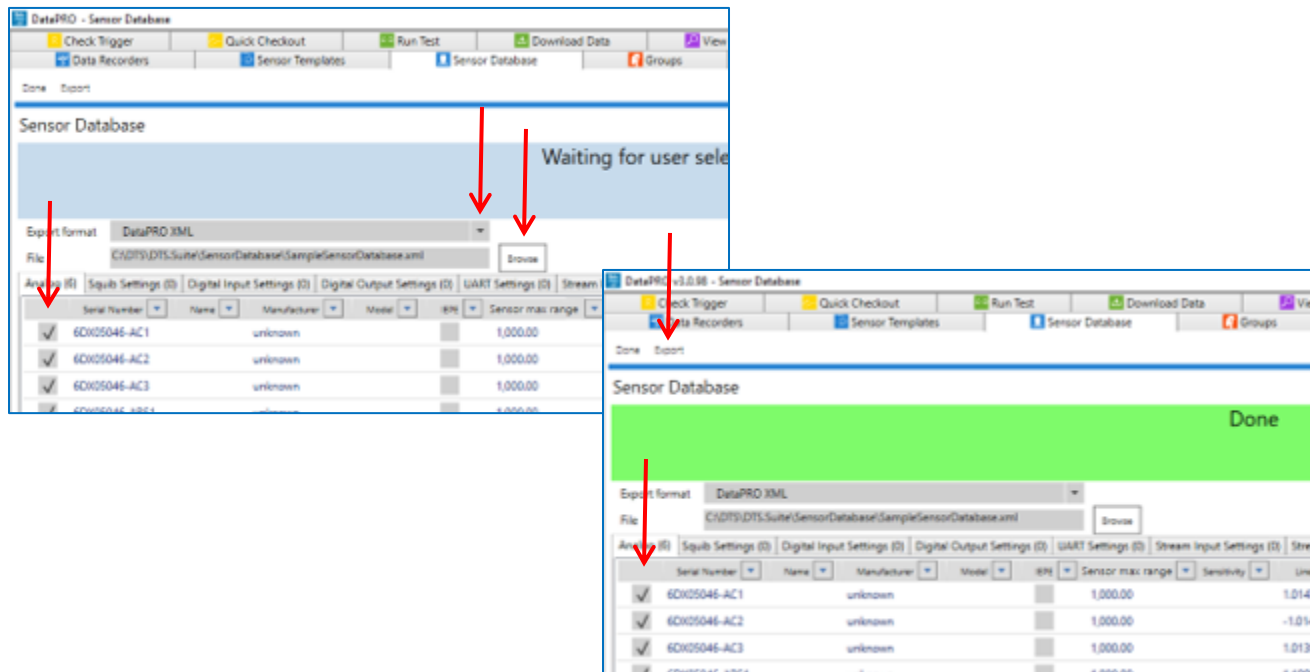

Delete

14. To delete a sensor from the database, select the sensor from the list, select “Delete” and then “Yes” to confirm:

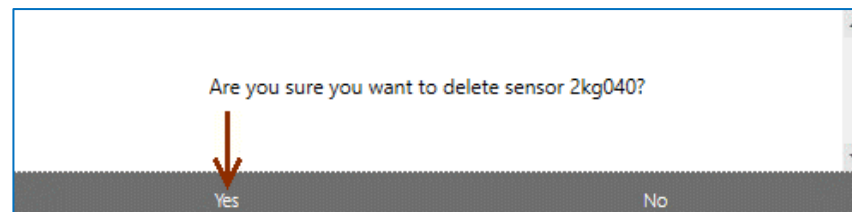
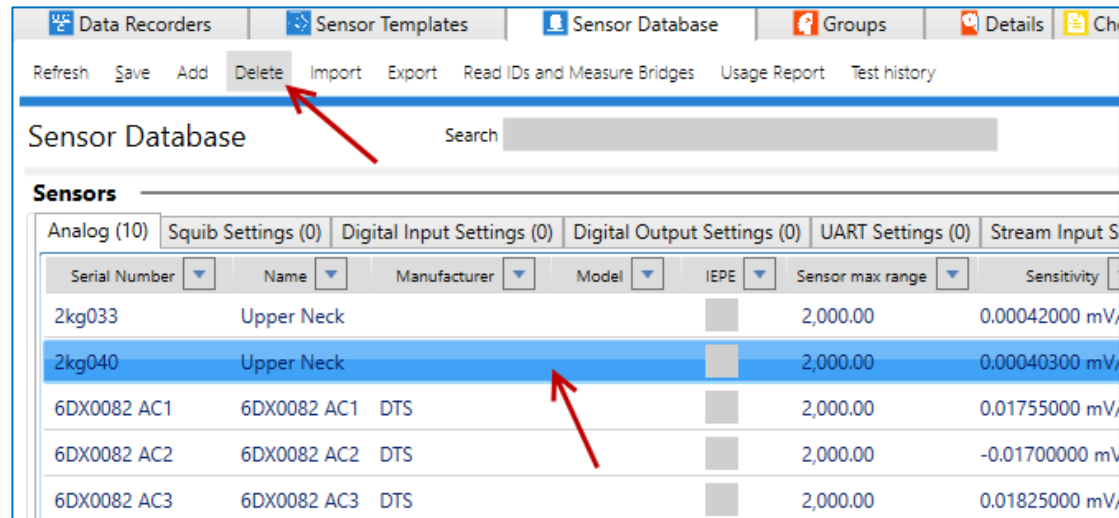

a. Select and delete multiple sensors by using Shift or CTRL.

15. To delete *all* sensors from the database, select “Delete all” and then “Yes” to confirm.

a. The ability to delete all sensors must first be enabled in the *DataPRO.exe.config* file by setting ShowDeleteAllSensorsButton to True.

NOTE: DTS recommends making a backup copy of the database before deleting all sensors.

16. To return to the Quick Start steps, go back to page 32.

Prepare

The tabs in the Prepare group allow for creation and management of commonly used test devices, test setup configurations and records used for certain data export formats.

Groups

Creating a group combines the sensors and (optional) DAS into one operational test device. Groups can be created using sensors, ISO Codes, User Codes, DAS or any combination thereof. Groups can also be imported/exported as *.xml or *.grp files. All sensors must exist in the sensor database in order to import a group file.

- To add a group, start at step 1.
- To import a group, go to step 8.
- To export a group, go to step 12.
- To edit a group, go to step 19.
- To delete a group, go to step 20.
- To copy a group, go to step 21.

NOTE: Only ISO Codes are displayed in the below images. To enable User Codes see [System Settings](#), page 210.

Add

1. Select the “Groups” tab:



2. Select “Add” to create a group:

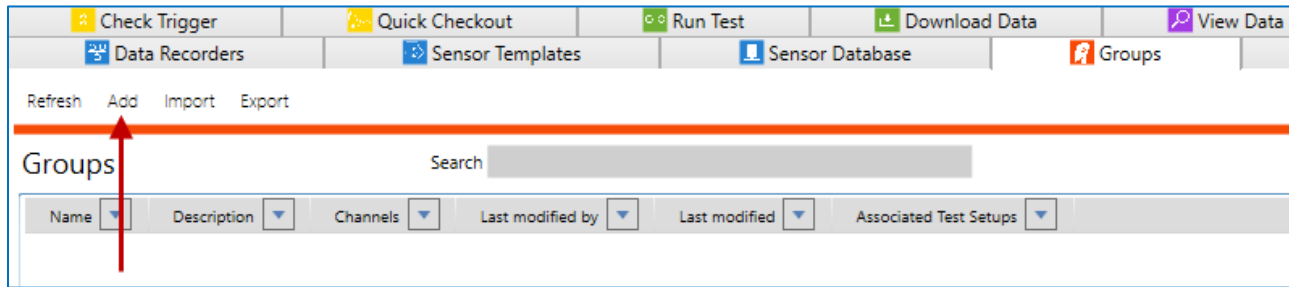

3. Enter a name for the group, and an optional description:

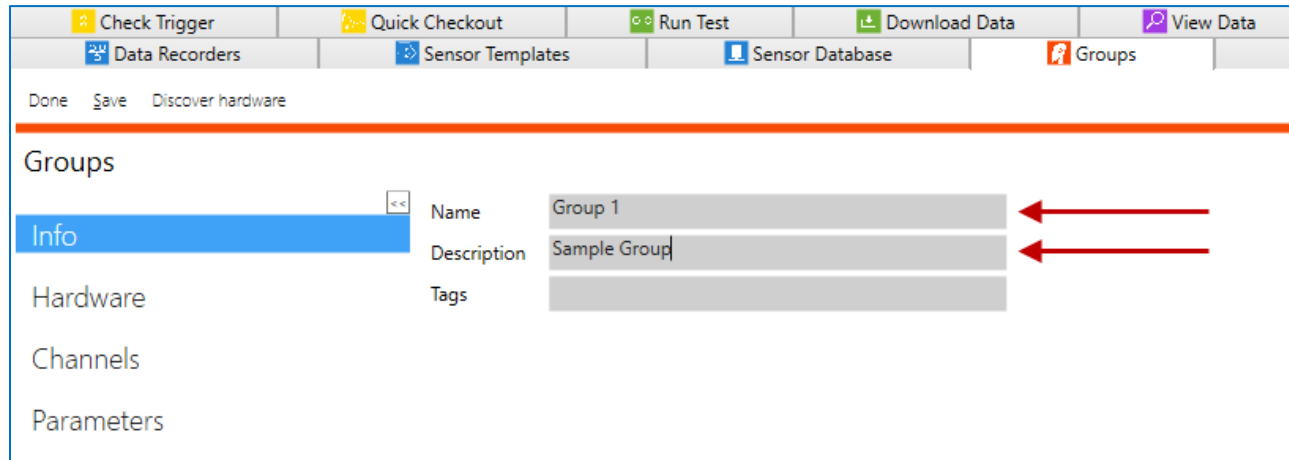

4. Add **Hardware** (optional), otherwise skip to step 5:

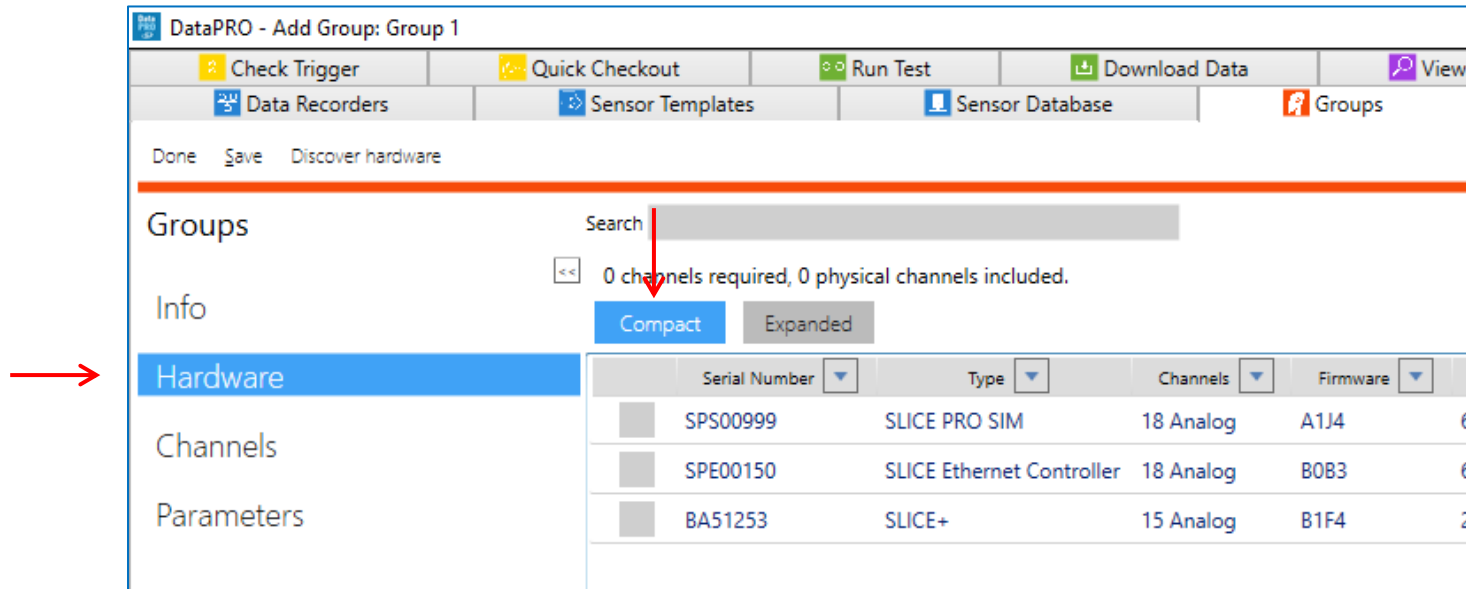

- a. Select Compact or Expanded to configure display of DAS table.
 - i. Expanded will show all selectable DAS units (SLICE PRO modules, SLICE Micro/Nano Base units, SLICE 6/SLICE6 AIR units, Distributors, TDAS PRO Racks and TDAS G5 units).
 - ii. Compact will display the Distributor or Base of configured DAS systems as well as modules that are not currently configured in a DAS system.
- b. If the DAS is known and has been added to the data recorder database, select the appropriate checkboxes.
- c. To add DAS to the list when the DAS is powered on and connected, select "Discover Hardware". See [Appendix C: Discover Hardware](#), page 266, for instructions on how to use Discover Hardware.

5. On the **Channels** navstep, assign channels to groups and (optionally) DAS hardware channels to the group:

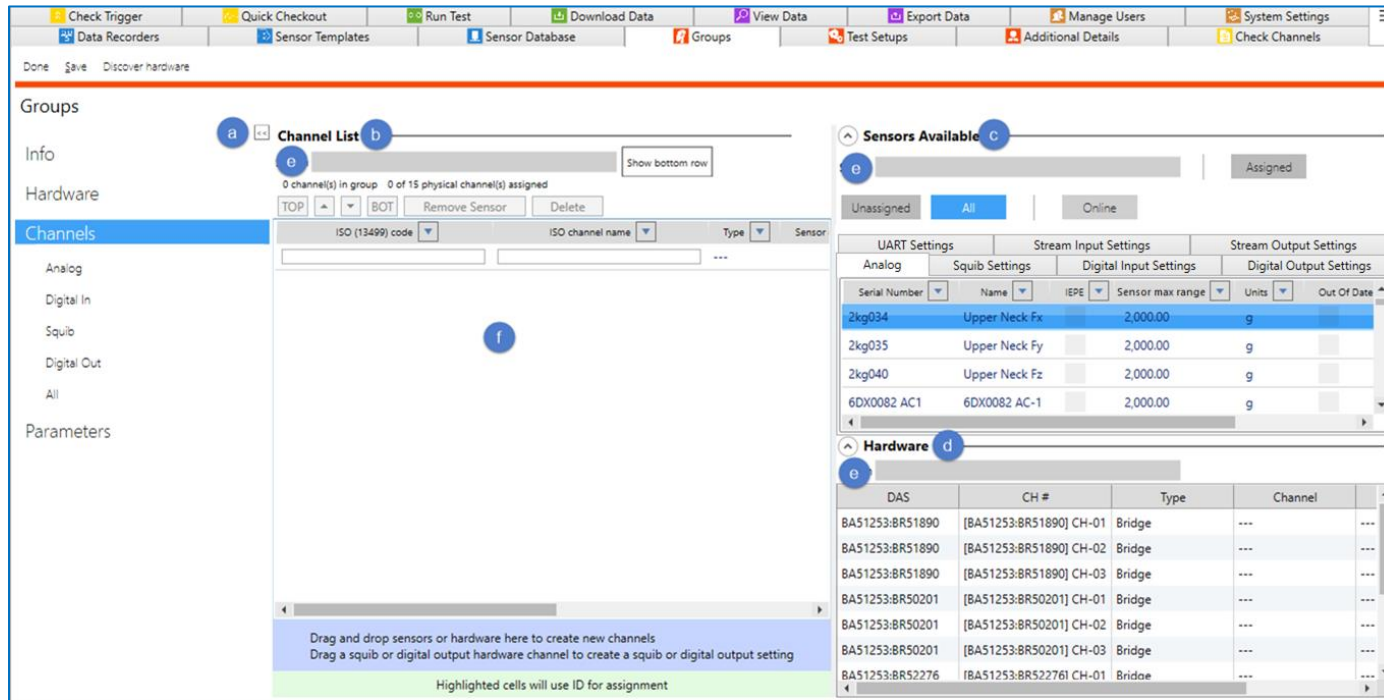

- a. Use the 'Snap Arrows' to collapse the Navigation Pane.
- b. Channel List table displays all channels assigned to the Group.
- c. Sensors Available table displays all sensors in the Sensor Database; use toggle buttons to filter the table.
 - i. "Assigned" - displays only sensors that have been assigned to the group.
 - ii. "Unassigned" - displays only sensors that have not been assigned and are available.
 - iii. "All" - displays all sensors, regardless of assignment.
 - iv. "Online" - displays only sensors that were found during Discover Hardware.
- d. If hardware is included in the group, available DAS channels will be displayed in the Hardware table.
 - i. DAS channels highlighted green indicate channel assignment, either manually or by EID
- e. Use search bar to search within table.

- f. Add channels to the group.
 - i. Select sensors from Sensors Available table and drag to Channel List table to add channels to group:

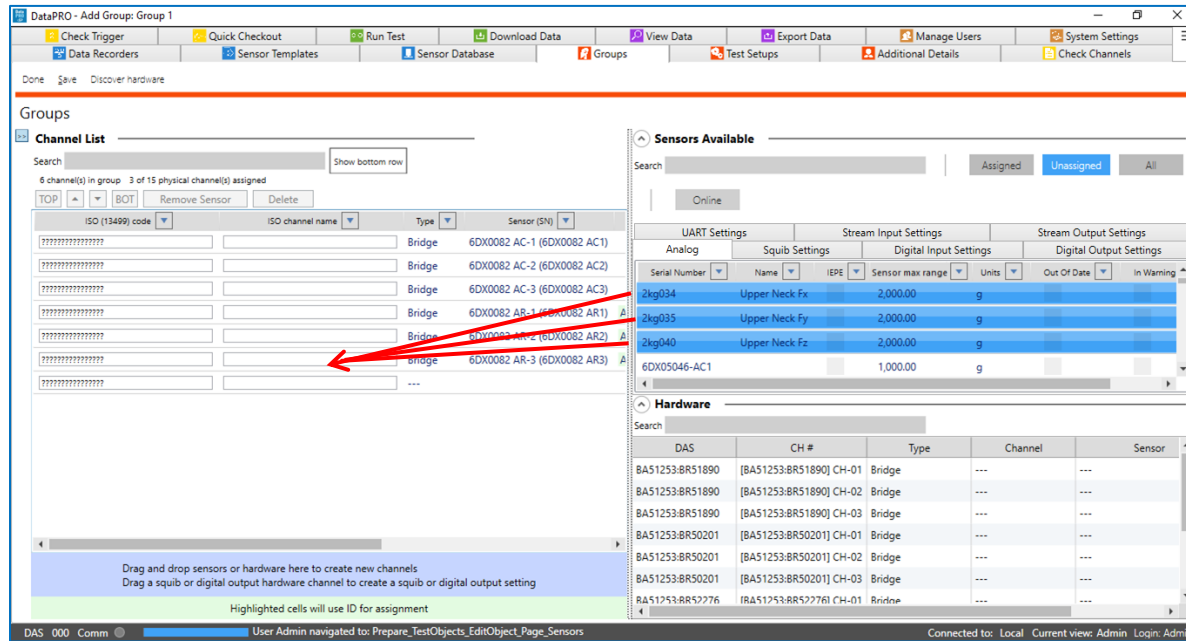

- Sensors that have EIDs will be shaded green in the Hardware column of the Channel List table;
- Sensors that do not have EIDs will have standard grey/white shading and will need to be manually assigned to a hardware channel before collecting data. (This can be done in the group, the Test Setup, or in the Check Sensor ID navstep).

- ii. Select hardware channels from Hardware table and drag to Channel List to add channels to group:

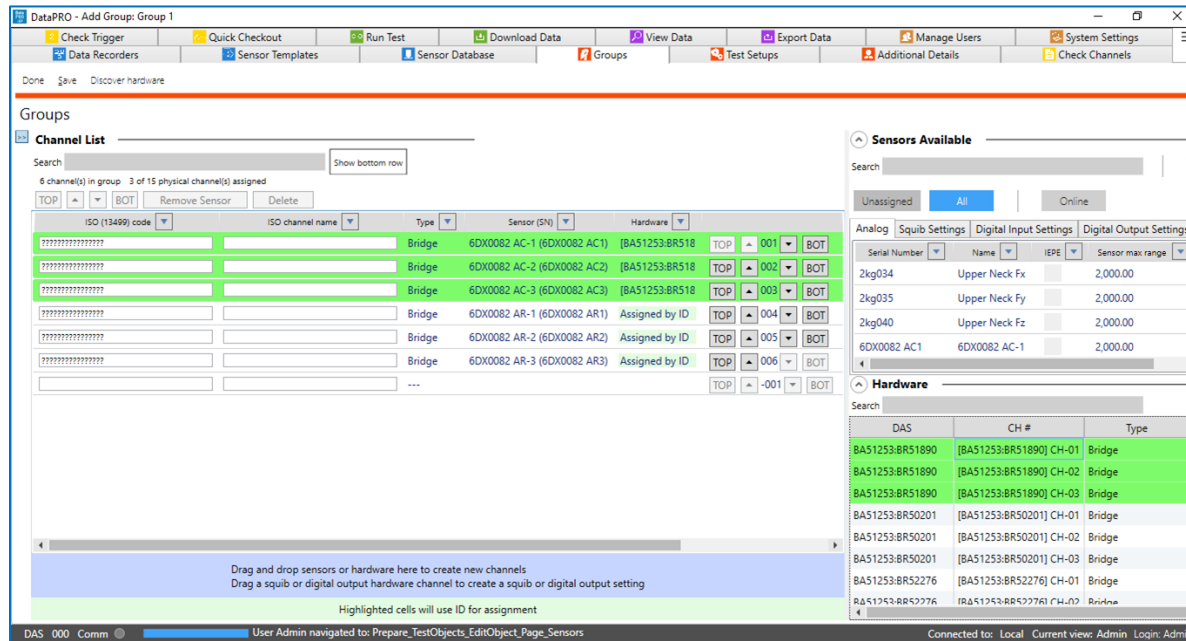

- Group Channels created by adding hardware channels will have default settings as defined in System Settings, page 210;
- All channel types can be created by adding Hardware Channels to Channel List, however, Digital Input and Analog channels require a sensor to be assigned prior to use.

iii. Add ISO Code(s), User Code(s), or Channel Name(s) to add channels to the group:

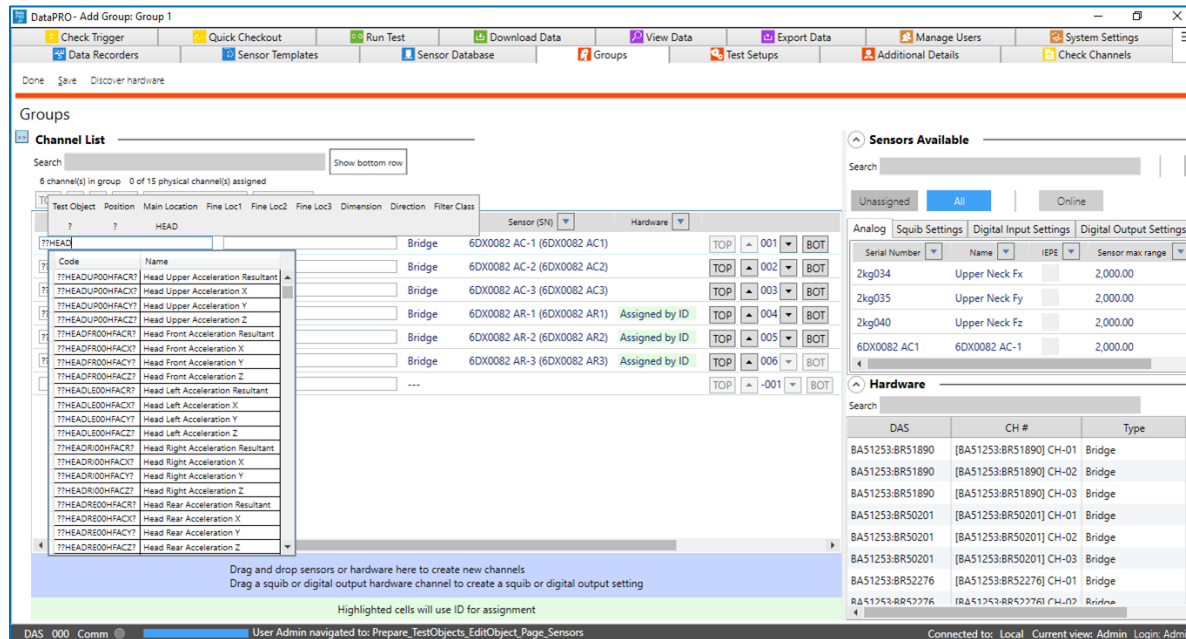

- Manually add ISO/User Code(s) or Chanel Name(s), or copy/paste multiple to create multiple Group Channels;
 - ISO Code Builder and Lookup Table are optional and can be disabled in **System Settings**, page 210;
- g. Select sensors from the Sensors Available table and drag to Channel List to assign to channels.
- i. A Group can be saved with channels added that do not have sensors assigned. These sensor-less-channels must have a sensor assigned once added to a Test Setup.

- h. Manually assign hardware channels to sensors without EIDs by dragging from the Hardware table to the Channel List table:

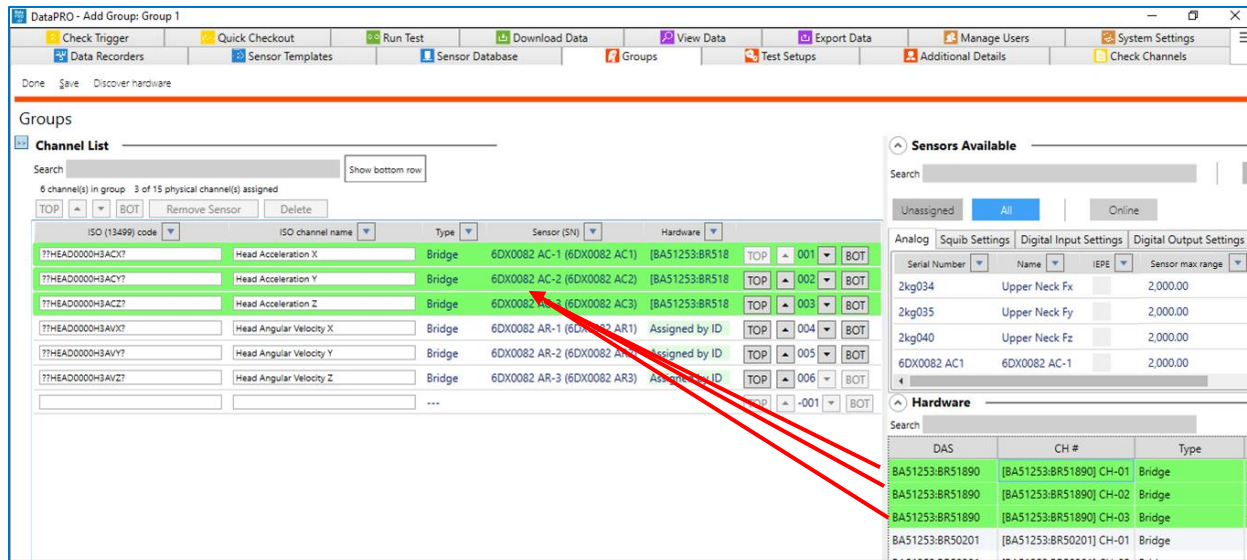

- 6. The **Parameters** navstep allows for modifications to certain channel parameters. These changes apply only to the Group. Select channel type to display parameters for that channel type (See Appendix A: Common Sensor Types and Bridge Connections, page 249, for more information about different sensor types and options during sensor entry).
 - a. Analog Channels:

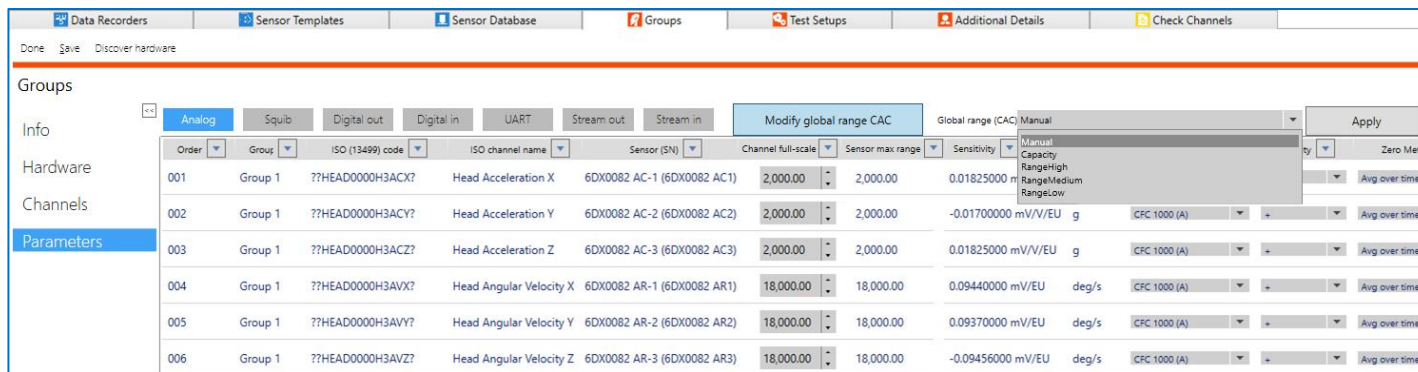

- i. Modify Channel full-scale capacity, Channel Filter Class, Polarity, Software Zero Method, Average Over Time Start/End and Initial Offset for individual Analog channels;
- ii. Select Modify Global Range CAC to modify the range for all Analog Channels based on High, Medium, Low Range and Capacity settings in Sensor Database;

b. Squib Channels:

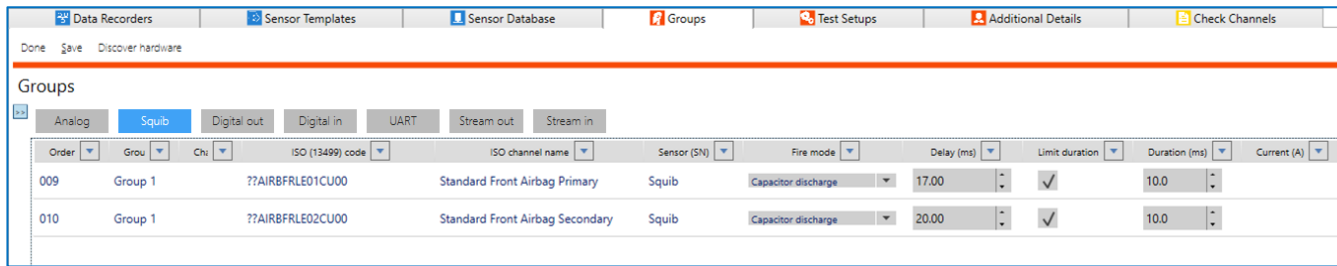

- i. Modify Fire Mode, Delay, Limit Duration, Duration and Current (if Constant Current is the selected Fire Mode).

c. Digital Output Channels:

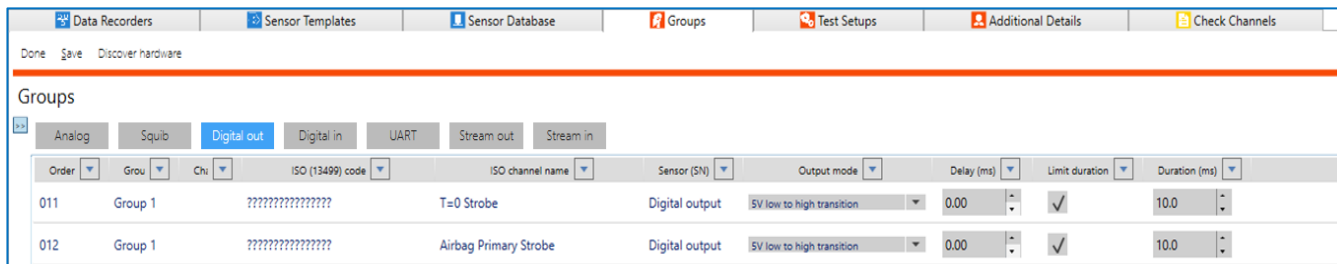

- i. Modify Output mode, Delay, Limit duration and Duration.

d. Digital Input Channels:

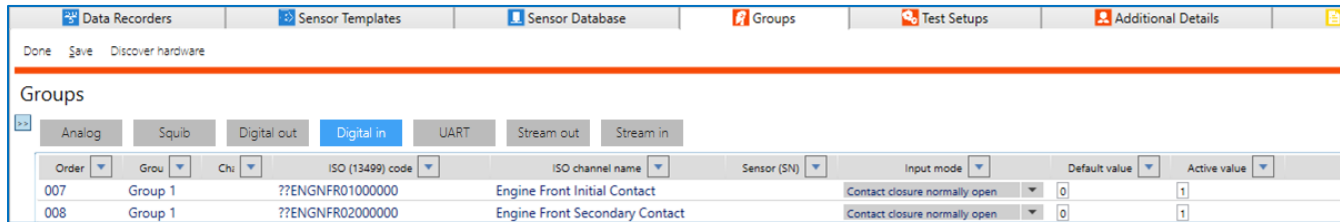

- i. Modify Input Mode, Default Value and Active Value.

e. UART Channels:

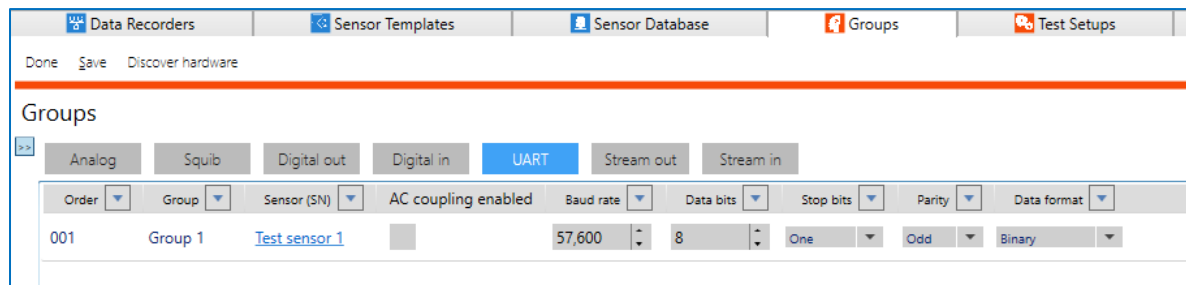

- i. Modify AC coupling enabled, Baud rate, Data bits, Stop bits, Parity, and Data format.

f. Stream Output Channels:

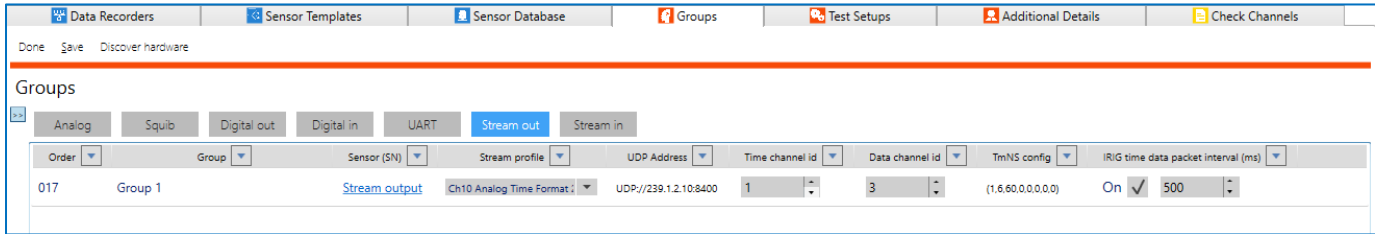

- i. Modify Stream profile and other parameters depending on the selected profile, including UDP Address, Time channel id, Data channel id, TmNS config, IRIG time data packet interval, Subframe Id, Message Id, Minor per major, TMATS port, TMATS interval, Source port, and IENA key.

g. Stream Input Channels:

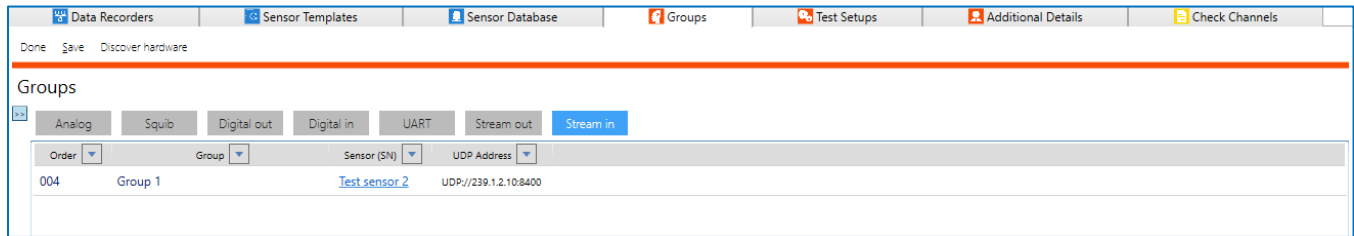

- i. Modify UDP Address.

7. To save the changes to the group, select “Save”:

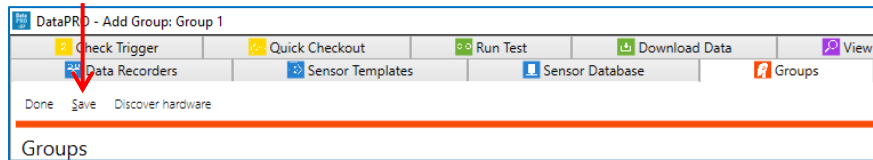

Import

8. To import a group, select “Import”:

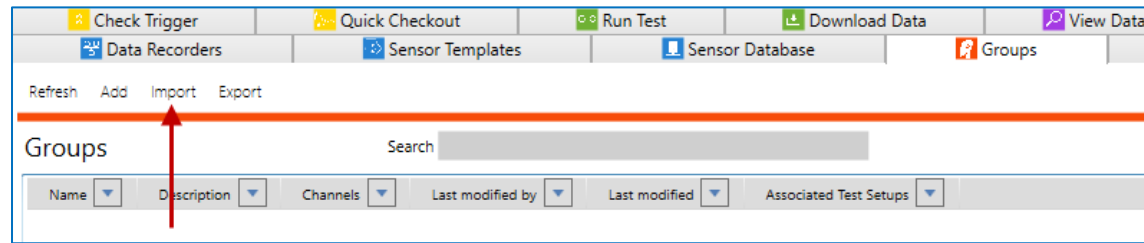

NOTE: Groups can be imported as *.xml or TDAS *.grp files. All sensors must exist in the Sensor Database in order for the group to be imported.

9. Select “Browse” and navigate to and select the *.xml or *.grp file to import:

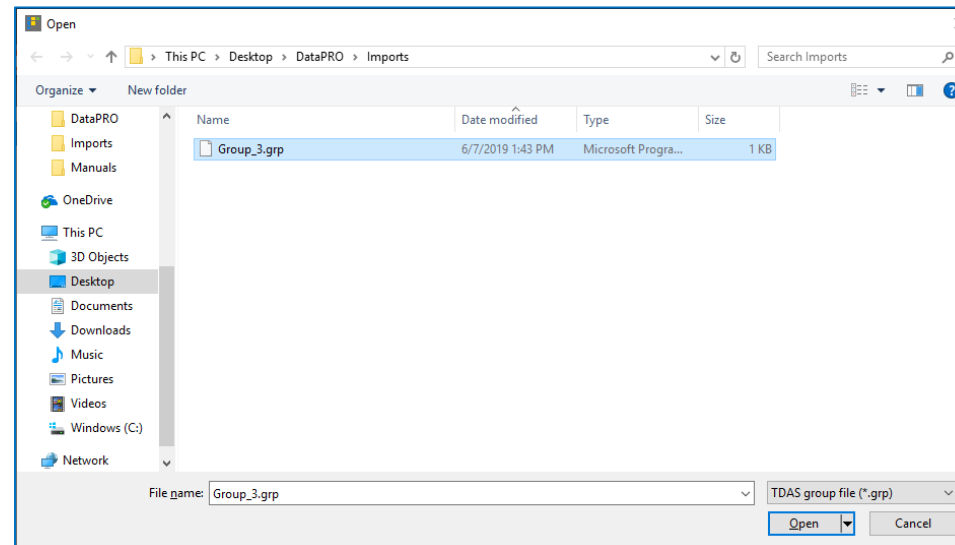

10. Make any necessary modifications in the preview:

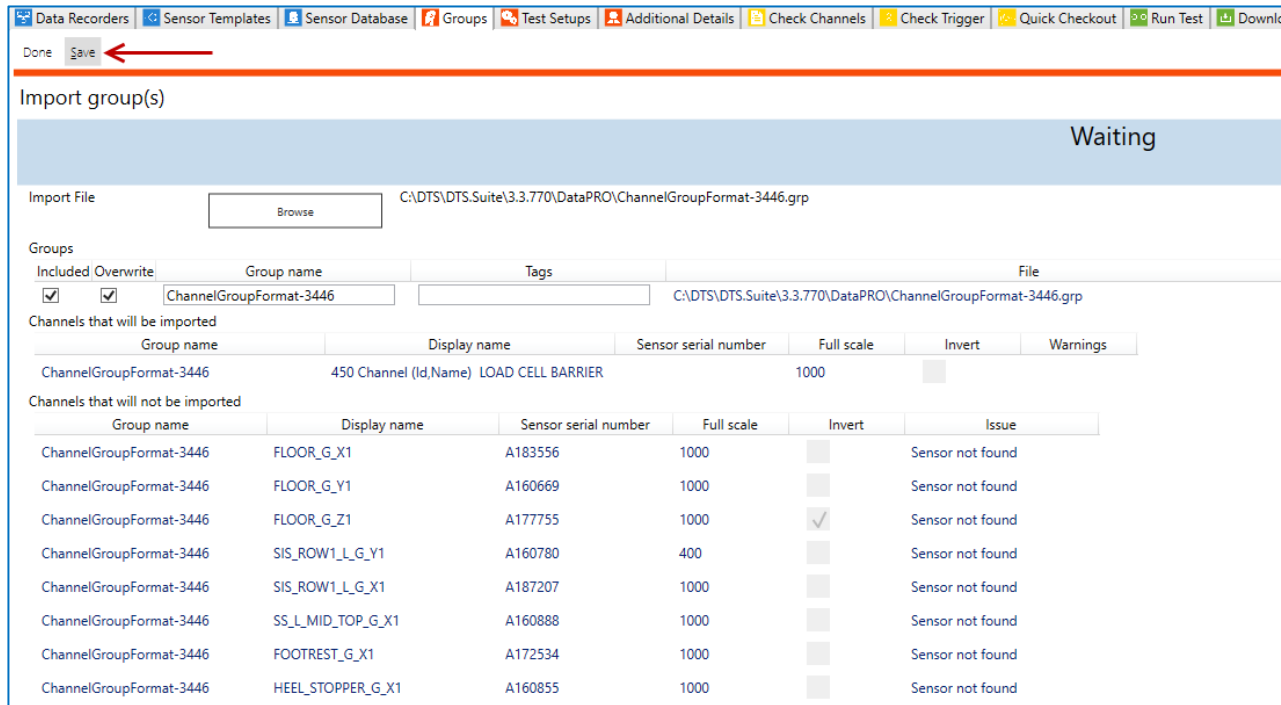

11. Select "Save" to import the group.

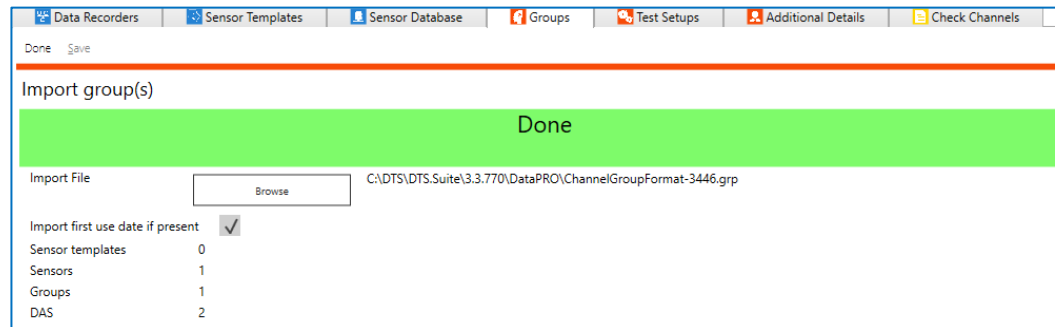

Export

12. To export a group, select “Export”:

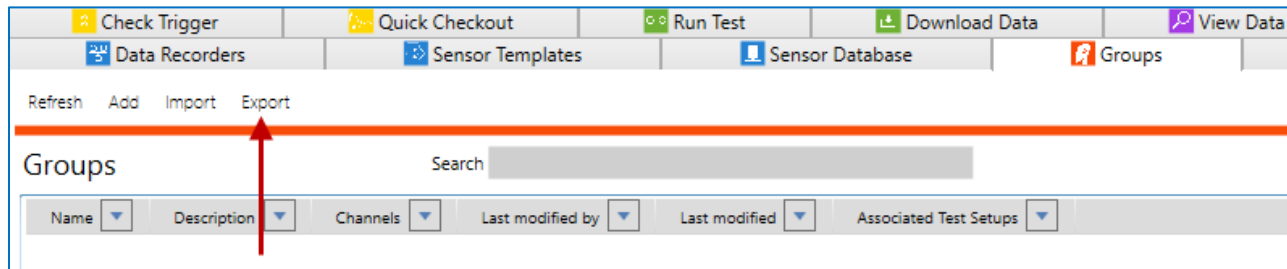

*NOTE: Groups are exported as *.xml files.*

13. Browse for the location you wish to save the export file:

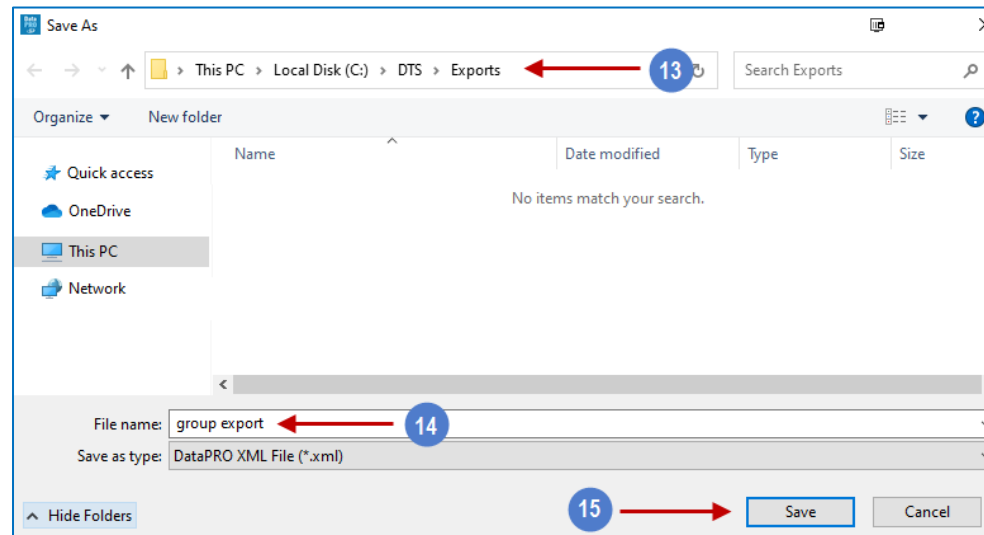

14. Type in the desired filename.

15. Select **Save**.

16. For each group you want to include in the export file, check the **Included** box next to that group.

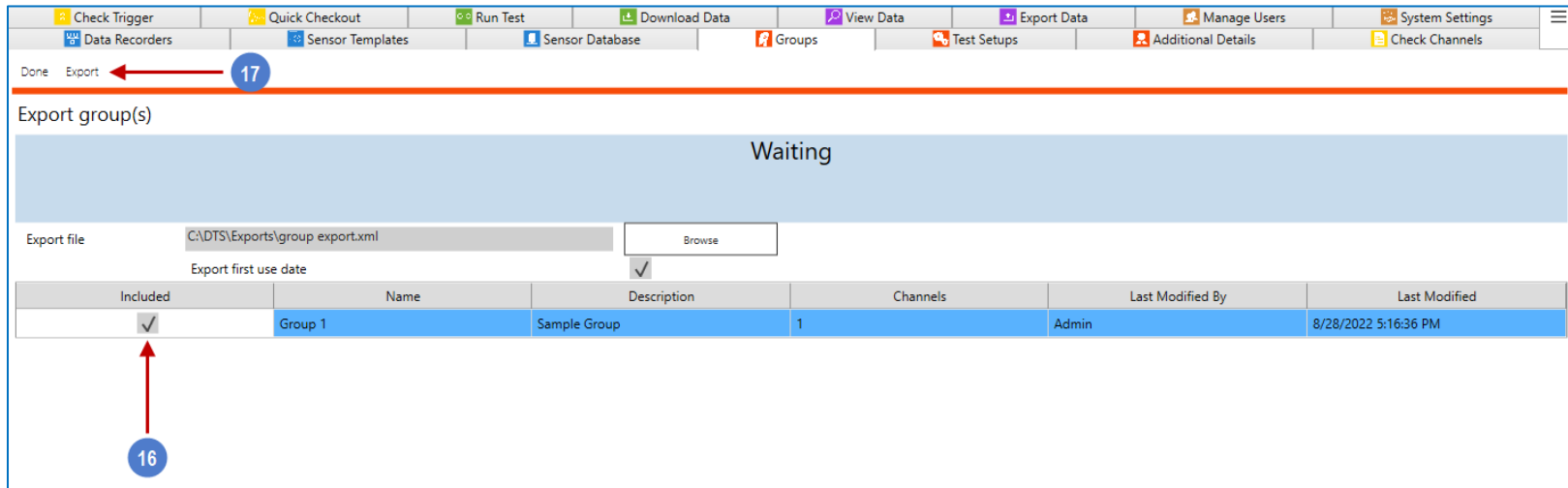

17. Select **Export**. When the export completes, the file will be saved to the location you selected.

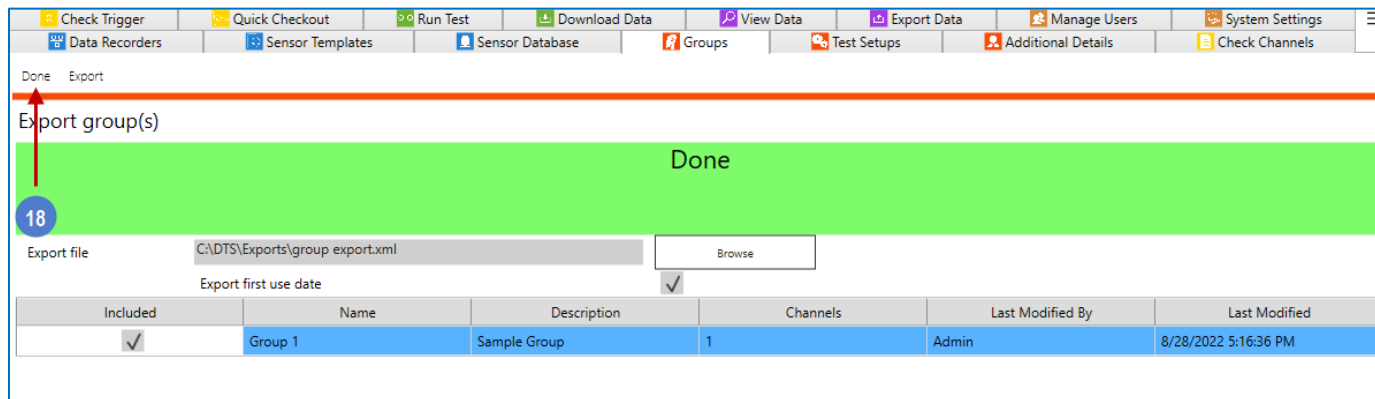

18. Select **Done** to return to the Groups screen.

Edit

19. To edit a group, double-click on the group –or– select the group and select “Edit” (see steps 3-7):

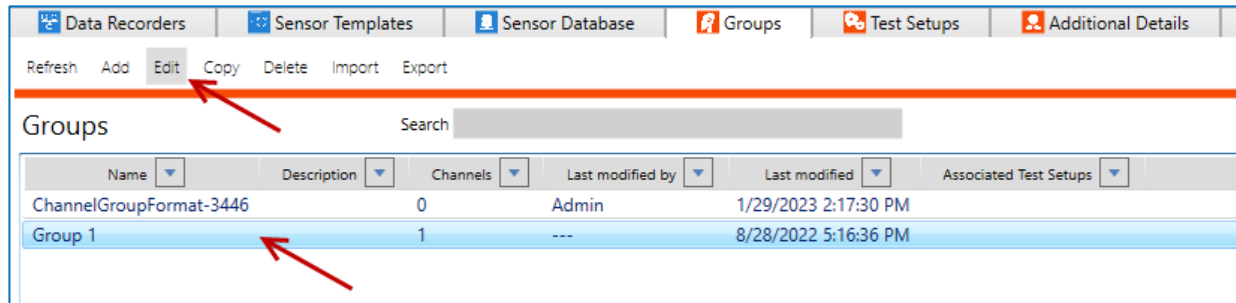

Delete

20. To delete a group from the database, select the group from the list, select “Delete” and then “Yes” to confirm:

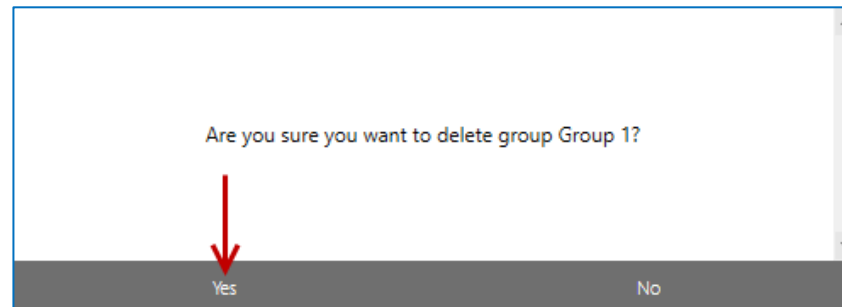
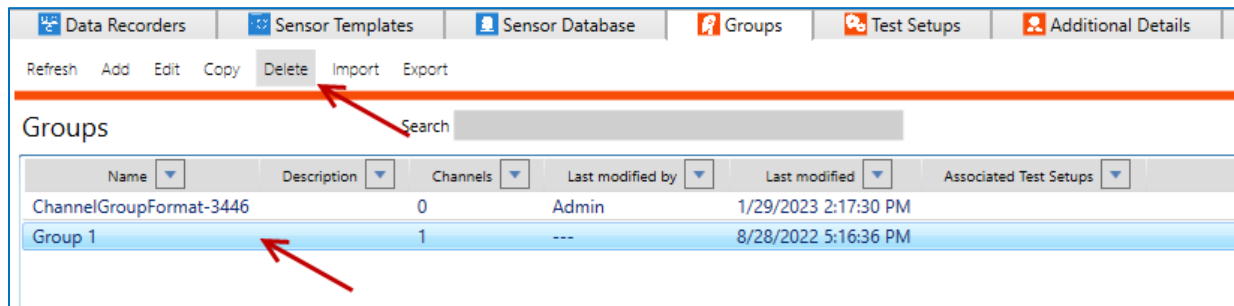

Copy

21. To copy a group, select the group to copy and select Copy:

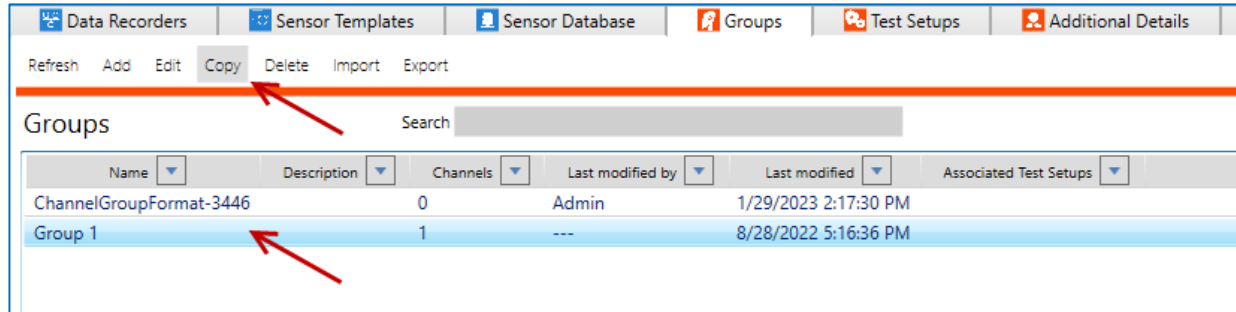

a. Enter a new Name and optionally enter a Description and Tag(s):

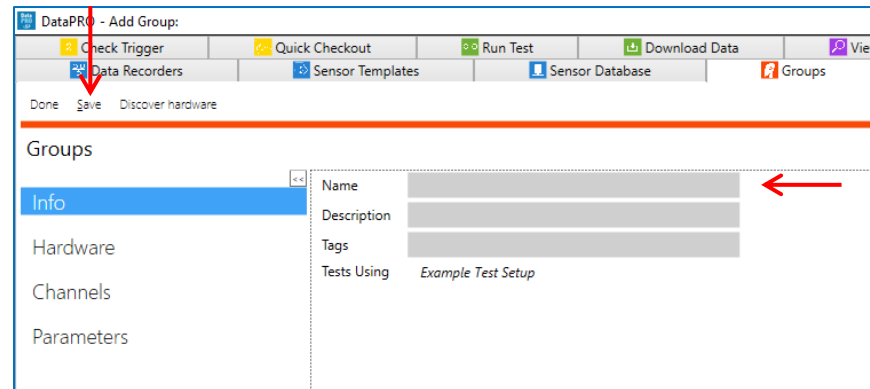

b. Select Save to save the new group to the database.

22. To return to the Quick Start steps, go back to page 32.

Test Setups

Test Setups are collections of measurement channels, hardware, and recording parameters used for data collection. Test Setups can contain existing predefined “Groups” or dynamic groups, or random collections of measurement locations and sensors. Each Test Setup can be used for multiple data collection events. (See [Groups](#), page 66 for instructions on creating a Group).

The steps and images below are for a “Record in Place” test, where data is stored on the internal flash memory of the DAS. For information on configuring SLICE6 AIR DAS for a Streaming test, see [Appendix I: SLICE6 AIR Setup](#), page 327.

- To add a test setup, start at step 1.
- To edit a test setup, go to step 14.
- To copy a test setup, go to step 15.
- To delete a test setup, go to step 16.
- To import a test setup, go to step 17.
- To export a test setup, go to step 18.
- To perform a quick build, go to step 20.
- To change the current/default test setup, go to step 21.
- To update to the latest SQL Server Test Setup settings, go to step 22.
- To generate a Test Setup Layout Report, go to step 23.

Add

1. Select the “Test Setups” tab:

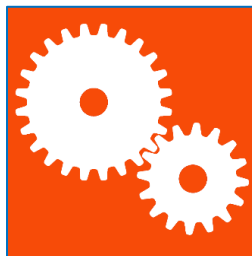

2. Select “Add” to create a new test setup:

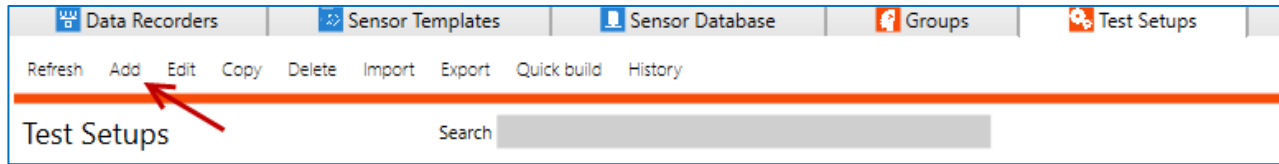

Info

3. The **Info** navstep contains various test details and options. All fields in **red** must be completed:

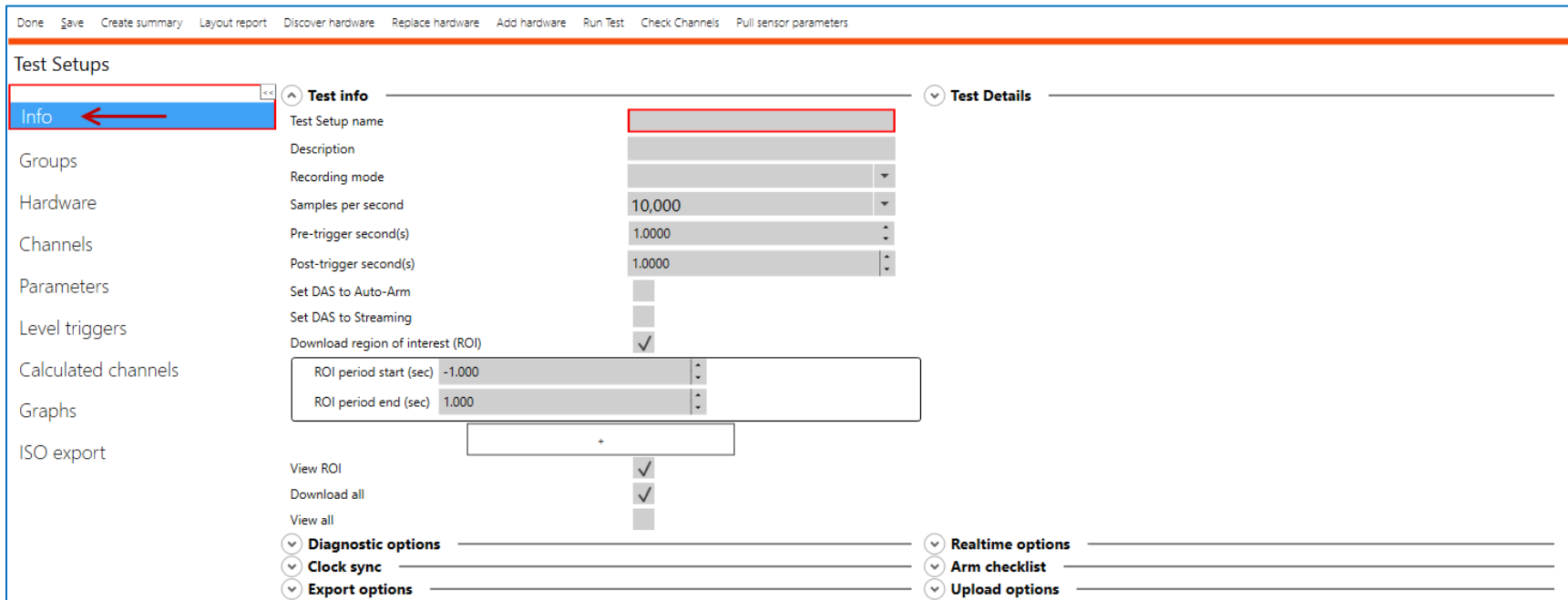

a. The default settings for these values can be configured on the System Settings tab (see page 210).

NOTE: *Level triggers and Calculated channels are optional navsteps that may be enabled by checking the “Enable level-trigger UI” and/or “Allow calculated channels” checkboxes in System Settings -> Test Settings.*

b. Use the arrows to expand/collapse each section menu:

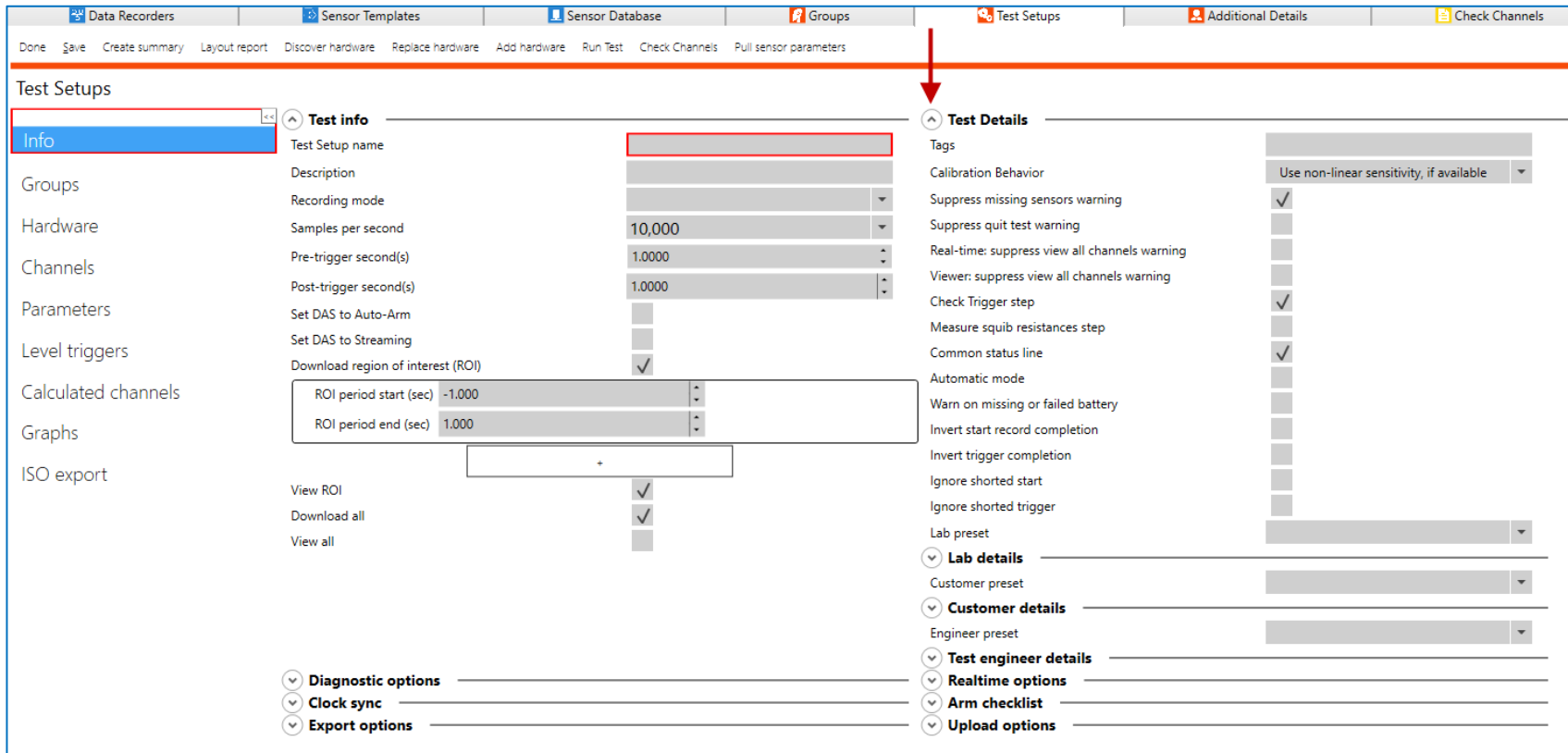

c. Test info:

Test info

Test Setup name: Sample Test

Description:

Recording mode: Continuous recorder

Number of events: 100

Samples per second: 10,000

Available recording time: 0 hrs, 0 mins.

Record on boot:

Set DAS to Auto-Arm: Repeat Auto-Arm:

Set DAS to Streaming:

Download region of interest (ROI):

ROI period start (sec): 0.000

ROI period end (sec): 0.010

View ROI:

Download all:

View all:

- i. **Test Setup name:** Name to identify Test Setup. (Each data collection event will have an additional, unique Test ID).
- ii. **Description:** Optional description of Test Setup.
- iii. **Recording mode:** Default recording mode options are Circular Buffer and Recorder Mode. Optional Hybrid Record and Continuous Recorder modes, and Active/Scheduled modes for TSR AIR devices, can be turned on in System Settings (See [Data Collection Concepts](#) page 17, for more information on recording modes. See [System Settings](#) page 210, to enable Advanced Recording Options).
- iv. **Number of events:** The number of events to record. Only applies to multiple event and continuous recorder modes.
- v. **Samples per second:** Choose from options in list to set one sample rate for all DAS in the Test Setup. If DAS in Test Setup have different sample rates, “Multiple” will be displayed. See

- vi. Hardware, page 98, for more information on selecting multiple sample rates.
- vii. **Pre-trigger second(s)**: The amount of data (in seconds) to be collected pre-trigger. Only applies to Circular Buffer Mode.
- viii. **Post-trigger second(s)**: The amount of data (in seconds) to be collected post-trigger.
- ix. **Event length in seconds**: The length of the event to record. Only available for TSR AIR DAS in Scheduled recording mode.
- x. **RTC Schedule start time (UTC)**: The time at which recording should start, in UTC. Only available for TSR AIR DAS in Scheduled recording mode.
- xi. **Start recording with event line**: Low power option that begins recording when the event is received. Pre-event data is not available with this option. Only available for TSR AIR DAS in Active recording mode.
- xii. **Wake up with motion**: The TSR AIR will wake up when sensing motion. Only available for TSR AIR DAS in Active recording mode. Does not work when there are level triggers less than or equal to 5g.
- xiii. **Available recording time**: When the recording mode is Record on boot or Record on boot + UART, the amount of time available for recording is also displayed. A Test Setup with a UART channel will only have half as much memory available, which affects the maximum test duration.
- xiv. **Record on boot**: If enabled, SLICE6 AIR DAS will begin recording immediately when rebooted.
- xv. **Set DAS to Auto-Arm**: When enabled, devices will be set to auto-arm rather than armed during the Arm step of Run Test. When devices are auto-armed they can be powered off or have the ON signal removed. The device will then arm after booting up when the ON signal is reapplied or the power is turned back on.
- xvi. **Record on Boot**: If enabled, SLICE6 AIR DAS will begin recording immediately when rebooted.
- xvii. **Set DAS to Streaming**: If enabled, SLICE6 AIR DAS will be configured to stream data when armed (See [System Settings](#), page 210, to enable Streaming Mode).
- xviii. **Repeat Auto-Arm/Repeat Streaming**: Only visible when either Set DAS to Auto-Arm or Set DAS to Streaming is checked. If enabled, DAS will automatically boot in an armed or streaming state. Note: when using a centralized database on an earlier version, these checkboxes will be disabled and reference the default value from System Settings -> Test Setup Settings -> Info -> Enable repeat when auto-arm/streaming.
- xix. **Download region of interest (ROI)**: A period of time within the full dataset that contains the dynamic test data. Must be enabled in System Settings. If enabled, DataPRO will download a dataset containing only the time window indicated as the ROI.
 - Use the plus sign (+) to add additional ROI segments to the test setup.
 - Use the minus sign (-) to remove ROI segments from the test setup.

NOTE: *If additional Regions of Interest are added, an “ROI x Channels” navstep will be present to allow the user to select which channels to include in each ROI.*

- xx. **ROI period start (sec)**: Defines the amount of time pre-trigger to begin the ROI.
 - Define ROI period Start for each included segment.
- xxi. **ROI period end (sec)**: Defines the amount of time post-trigger to end the ROI.
 - Define ROI period end for each included segment.
- xxii. **View ROI**: If enabled, data collection process will include a navstep to view the ROI.
- xxiii. **Download All**: If enabled, DataPRO will download a dataset containing the full dataset defined in Recording Options.
- xxiv. **View All**: If enabled, data collection process will include a navstep to view the full dataset.

d. Test Details:

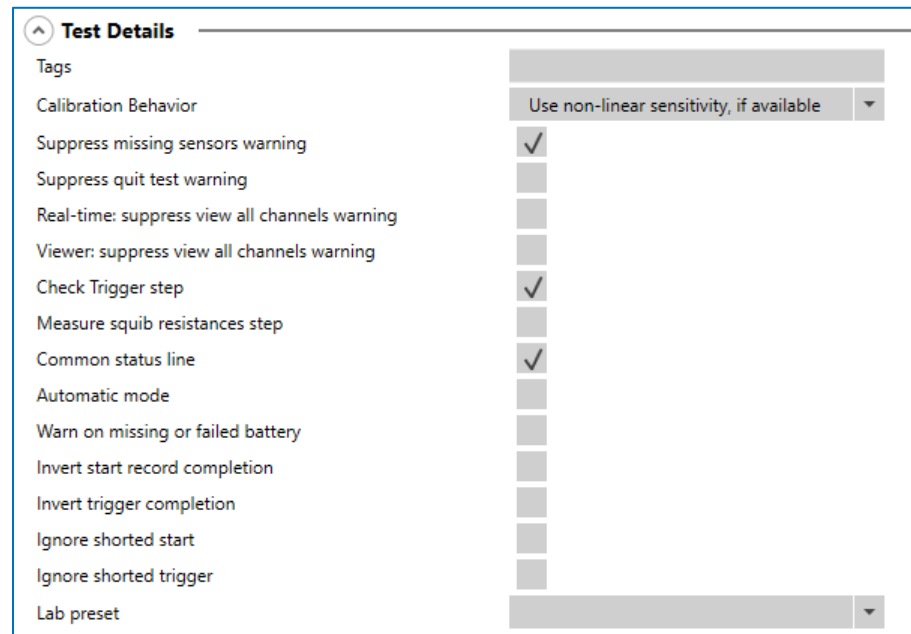

- i. **Tags**: Can be used to filter display/access to Test Setups. Must correspond to tags used in User Profiles.
- ii. **Calibration Behavior**: Select how to collect data from non-linear sensors that also have linear sensitivities.
 - Always use linear sensitivity: Only collect data using the linear sensitivity, regardless of non-linear sensitivity entry.
 - Use non-linear sensitivity, if available: Collect data with the non-linear sensitivity.

- Use both sensitivities, if available, as separate channels: Collect two data channels for each sensor; one for the non-linear sensitivity and one for the linear sensitivity.
- iii. **Suppress missing sensors warning:** If enabled, DataPRO will allow user to progress without warning if not all sensors are found/channels resolved at Check Sensor ID step.
- iv. **Suppress quit test warning:** If enabled, DataPRO will not warn if user selects “Done” before completing all steps of a data collection event.
- v. **Real-time: suppress view all channels warning:** If enabled, DataPRO will not warn if user does not view Realtime output from all channels in a test setup.
- vi. **Viewer: suppress view all channels warning:** If enabled, DataPRO will not warn if user does not review data collected from all channels in a test.
- vii. **Check Trigger step:** Select to include a trigger check during the data collection event.
- viii. **Measure squib resistances step:** Select to include a squib resistance measurement step for TOM channels during the data collection event.
- ix. **Common status line:** Select if all DAS shares same communication path to PC. A typical non-common status line would be a vehicle test that includes a mobile barrier.

NOTE: Tests that have multiple sample rates cannot have a common status line.

- x. **Automatic Mode:** Select to automatically progress through data collection sequence. If selected, define an optional delay before DataPRO progresses to the next step.
- xi. **Warn on missing or failed battery:** If selected, DataPRO will alert user if SLICE Nano DAS battery is missing or if measured voltage is outside thresholds set in System Settings (See [Power Settings](#), page 237).
- xii. **Invert start record completion:**
- xiii. **Invert trigger completion:**
- xiv. **Ignore shorted start:** If enabled, allows a test to continue without failing if the start signal is detected when Diagnostics is run. A use case for this would be to cause a DAS running in Recorder mode to begin collecting data immediately when armed.
- xv. **Ignore shorted trigger:** If enabled, allows a test to continue without failing if the event signal is detected when Diagnostics is run. A use case for this would be to cause a DAS running in Circular Buffer mode to begin collecting data immediately when armed.
- xvi. **Lab preset:** Select Lab Details record from list (See [Lab Details](#), page 123). Lab Details can be modified if a record is selected, or manually entered if no records exist.

- e. **Lab details:** Select Lab Details record from list (See [Lab Details](#), page 123). Lab Details can be modified if a record is selected, or manually entered if no records exist.



The screenshot shows a dropdown menu titled "Lab details" with a downward arrow icon on the left. Below the title, the text "Customer preset" is displayed. To the right of the text is a grey rectangular area with a small downward arrow icon, indicating the current selection.

- f. **Customer details:** Select Customer Details record from list (See [Customer Details](#), page 124). Customer Details can be modified if a record is selected, or manually entered if no records exist.



The screenshot shows a dropdown menu titled "Customer details" with a downward arrow icon on the left. Below the title, the text "Engineer preset" is displayed. To the right of the text is a grey rectangular area with a small downward arrow icon, indicating the current selection.

- g. **Test engineer details:** Select Engineer Details record (See [Engineer Details](#), page 125). Engineer Details can be modified if a record is selected, or manually entered if no records exist.



The screenshot shows a dropdown menu titled "Test engineer details" with a downward arrow icon on the left. Below the title, there is a grey rectangular area with a small downward arrow icon, indicating the current selection.

h. Diagnostic options:

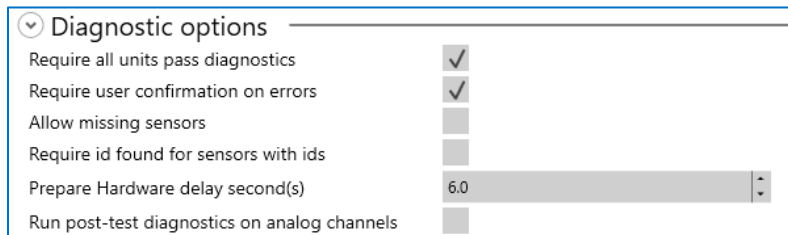

- i. **Require all units pass diagnostics:** If enabled, DataPRO will not advance beyond Diagnostics navstep if any channels fail or if measured DAS voltage is outside thresholds set in System Settings.
- ii. **Require user confirmation on errors:** If enabled, DataPRO will require user confirmation in order to progress if any errors are detected.
- iii. **Allow missing sensors:** If enabled, DataPRO will allow user to progress if sensors in Test Setup still require hardware channel assignments.
- iv. **Require id found for sensors:** If enabled, DataPRO will require the EID to be detected for any sensor that has an EID listed in the sensor database.
- v. **Prepare hardware delay second(s):** Optional delay at the start of Diagnostics for sensor/hardware warm up.
- vi. **Run post-test diagnostics on analog channels:** If enabled, Post-Test Diagnostics will be included as a step in data collection process. For tests that include TDAS G5 DAS, pre-test diagnostics will be displayed.

i. Realtime options:



- i. **Show Realtime:** If enabled, Realtime navstep will be included in data collection process.
- ii. **Number of graphs:** Select to display 1, 3 or 6 separate charts at Realtime landing. This can be changed from Realtime navstep.

- j. **Clock sync:** Choose desired clock sync options for devices which support it, such as SLICE6, SLICE6 AIR, and TSR AIR. This section is only visible if “Enable input and output clock source options” is enabled in System Settings -> Test Settings. More information on the various clock sync options can be obtained from DTS support.



- i. **System grand master type:** Choose from None, PTP IEEE 1588, IRIG B + 1PPS, GPS + 1PPS, IRIG B, or 1PPS. This dropdown works in conjunction with hardware that is selected in the Hardware step, and what hardware is selected (if any) as a clock master to determine the clock source for DAS.
- k. **Arm checklist:** The Arm Checklist is automatically added and required to pass for tests that include a TOM. This behavior can be changed by modifying the configuration file (See the DataPRO Settings manual for information regarding making changes to the config file):

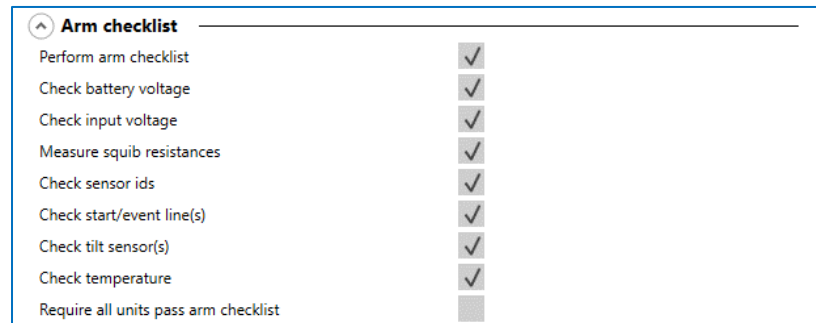

- i. **Perform arm checklist:** If enabled, DataPRO will perform Arm Checklist during data collection. Arm checklist test options will only be displayed if Arm Checklist is enabled.
- ii. **Check battery voltage:** If enabled, Arm Checklist will include battery voltage measurement. Arm Checklist will fail if measured battery voltage is outside thresholds set in System Settings (See page 210).
- iii. **Check input voltage:** If enabled, Arm Checklist will include input voltage measurement. Arm Checklist will fail if measured input voltage is outside thresholds set in System Settings (See page 210).
- iv. **Measure squib resistances:** If enabled, Arm Checklist will include squib resistance check on TOM channels. Arm Checklist will fail if measured squib resistance is outside threshold set in Sensor Database (See page 52).
- v. **Check sensor ids:** If enabled, Arm Checklist will include sensor ID check. Arm Checklist will fail if expected IDs are not found.

- vi. **Check start/event line(s):** If enabled, Arm Checklist will include check of start/event status lines. Arm Checklist will fail if DataPRO detects a short on either.
- vii. **Check tilt sensor(s):** If enabled, Arm Checklist will include check of SLICE6 tilt sensor(s). Measured values will only be displayed.
- viii. **Check temperature:** If enabled, Arm Checklist will include check of SLICE6 temperature. Measured values will only be displayed.
- ix. **Require all units pass arm checklist:** If enabled, DataPRO will not progress to Arm System if any faults are detected in any tests included in Arm Checklist.

NOTE: *Squib resistance failure will prevent progressing to Arm navstep regardless of “Require all units to pass arm checklist” setting.*

I. Export options:

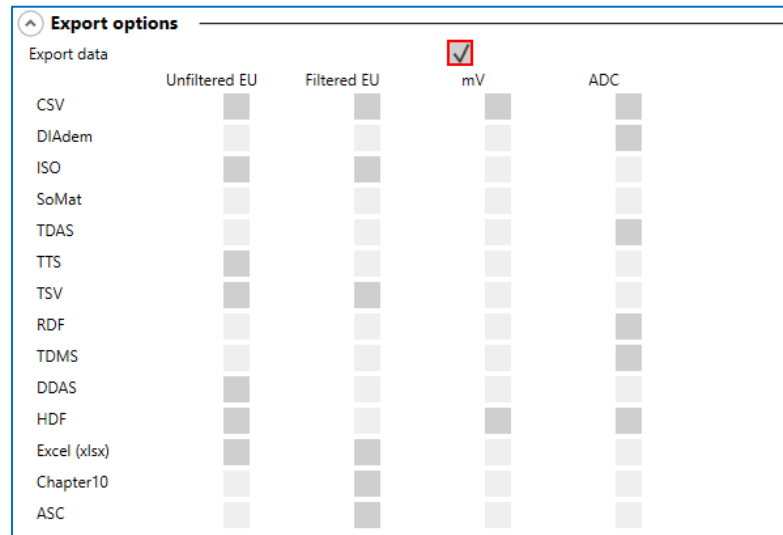

- i. **Export data:** If enabled, DataPRO will export a data set in each of the selected format(s). Raw data is always downloaded.
- ii. **CSV:** All test data is contained in one Comma Separated Variable file.

- iii. **DIAdem**: Data format comprised of one .dat header file for the test and one binary file for each channel in the test.
- iv. **ISO**: Data format that follows the ISO-TS 13499 requirements.
- v. **SoMat**: Data format compatible with SoMat DAQ.
- vi. **TDAS**: Data format compatible with TDAS Control.
- vii. **TTS**: Customer specific data format.
- viii. **TSV**: All test data is contained in one Tab Separated Value file.
- ix. **RDF**: Customer specific data format.
- x. **TDMS**: Data format that follows the TDM Streaming file format.
- xi. **DDAS**: Customer specific data format.
- xii. **HDF**: Hierarchical Data Format; designed to store and organize large amounts of data.
- xiii. **Excel (xlsx)**: Data format compatible with Microsoft Excel.
- xiv. **Chapter10**: IRIG 106 Chapter 10 Digital On-Board Recorder Standard for flight data recorders.
- xv. **ASC**: Customer specific data format.

m. Upload options:

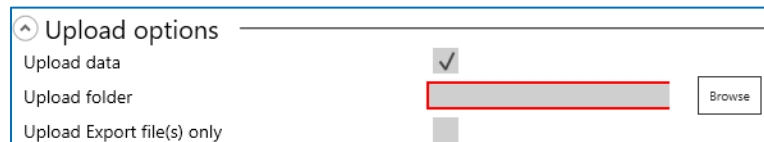

- i. **Upload data**: If enabled, collected data will be uploaded to a specified location during the data collection process. Data will still be downloaded to the default location (*C:\DTS\DTS.Suite\Data*), or other location defined in the configuration file.
- ii. **Upload folder**: File location for collected data to be uploaded to during data collection process.
- iii. **Upload Export file(s) only**: If enabled, will upload only data export files.

Groups

4. Select the **Groups** navstep to add groups to the Test Setup:

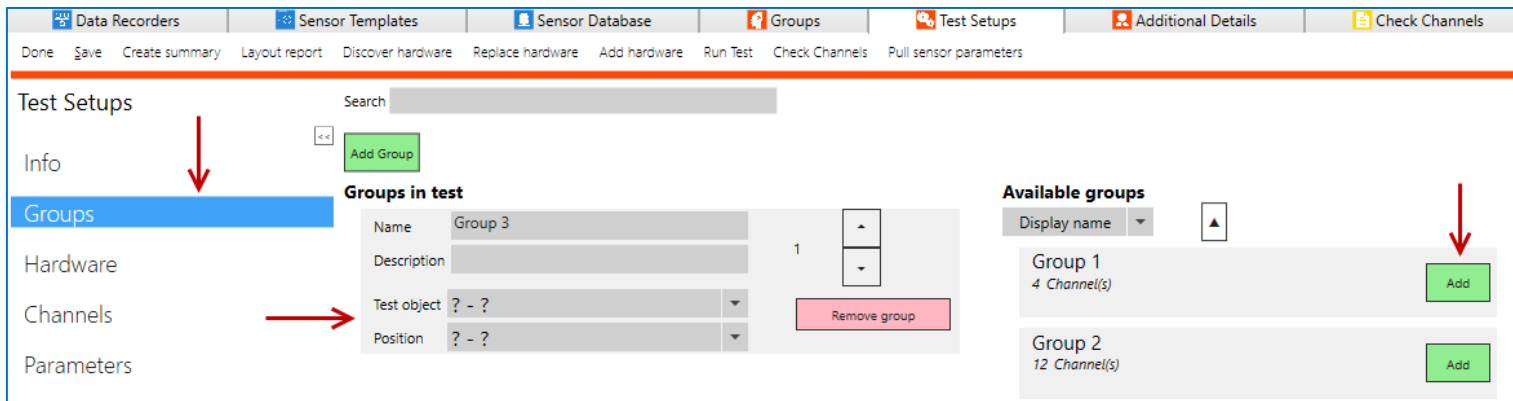

- a. Add pre-defined groups to the “Groups in test” by selecting “Add” for the appropriate available group.
 - i. If using ISO Codes, enter/update the Test Object and Position for each group that has been added. Test Object and Position can be modified per channel in the Channels navstep; “Mixed” will be displayed if a single group contains multiple values. Note: if the option to “Use dropdown lists for test object and position” is enabled in System Settings -> Test Settings, these fields will be a dropdown list instead of text entry.
 - ii. The list of available groups may be sorted by display name, description, channel count, last modified, or last modified by. The preferred sort direction and field are saved on a per-user basis.
- b. Remove a group from a test by selecting “Remove group” for the appropriate group. Pre-defined groups will be returned to the list of Available Groups.

- c. A temporary, dynamic group can be added by selecting “Add Group” or by adding additional channels in the Channels navstep and assigning a group name to these added channels:

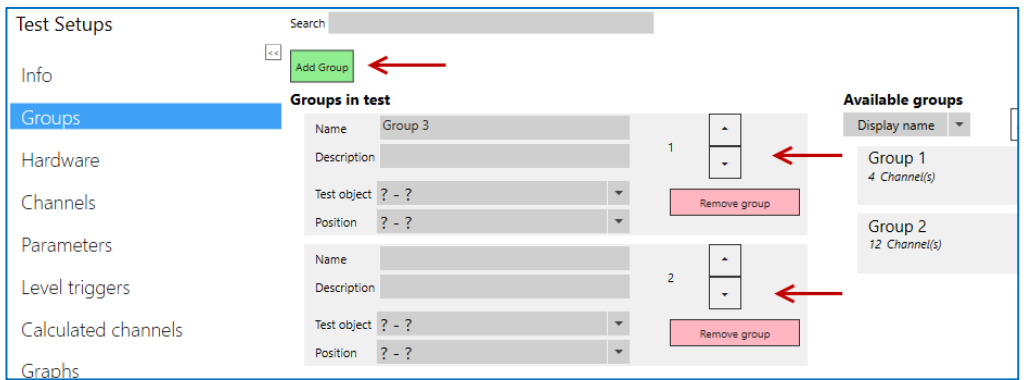

- i. Use the arrows to change the order of groups in the test setup.

Hardware

5. Select the **Hardware** navstep to add DAS to the test setup:

The screenshot shows the 'Test Setup' interface. On the left sidebar, the 'Hardware' navstep is selected. The main area displays a table of hardware units. The table has the following columns: Serial Number, Type, First Use Date, Channels, Firmware, Max Sample Rate, Test Sample Rate, Cal Date, and Cal D. The table is currently in 'Expanded' view. A red arrow points to the 'Hardware' navstep, and another red arrow points to the 'Expanded' button above the table.

Serial Number	Type	First Use Date	Channels	Firmware	Max Sample Rate	Test Sample Rate	Cal Date	Cal D
SPT00999	SLICE PRO TOM	N/A	4 Squib,8 Digital out channel(s)	D0D7	600,000		4/7/2016	4/7/20
SPT00107	SLICE PRO TOM	N/A	4 Squib,8 Digital out channel(s)	D0M1	1,000,000		5/15/2020	5/15/2
<input checked="" type="checkbox"/> SPS00331	SLICE PRO SIM	8/20/2020	18 Analog channel(s)	A1R4	600,000	10,000	5/15/2020	8/20/2
<input type="checkbox"/> SPS00123	SLICE PRO SIM	8/20/2020	18 Analog channel(s)	A1J4	600,000		4/7/2016	4/7/20
<input checked="" type="checkbox"/> SPE00150	SLICE Ethernet Controller	N/A	18 Analog channel(s)	B0B3	---		5/15/2020	8/20/2
<input type="checkbox"/> SPD00999	SLICE PRO DIM	N/A	18 Digital input channel(s)	A1J4	600,000		4/7/2016	4/7/20
<input type="checkbox"/> SDB0090	SLICE Distributor	N/A	---	00A6	---		4/7/2016	4/7/20

- Any hardware that is assigned to a pre-defined group that is included in the 'Groups in test' will automatically be added to the Test Setup.
- Additional DAS can be added by selecting the appropriate check box in the Included column, or by selecting "Discover hardware" (See [Appendix C: Discover Hardware](#), page 266, for more information) to auto-detect DAS, or "Add hardware" (see step d) to add DAS manually or add generic DAS.
- Select "Expanded" to display all selectable DAS units or "Compact" to display DAS systems and individual units that are not configured with a DAS system.

The screenshot shows the 'Test Setup' interface with the 'Hardware' table in 'Expanded' view. The table has the following columns: Serial Number, Type, Channels, Firmware, Max Sample Rate, Test Sample Rate, Cal Date, and Cal Due Date. A red arrow points to the 'Expanded' button above the table.

Serial Number	Type	Channels	Firmware	Max Sample Rate	Test Sample Rate	Cal Date	Cal Due Date
<input type="checkbox"/> BA51253	SLICE+	15 Analog	B1F4	200,000		4/29/2019	4/28/2020
<input type="checkbox"/> SPD00999	SLICE PRO DIM	18 Digital input	A1J4	600,000		4/7/2016	4/7/2017
<input checked="" type="checkbox"/> SPE00150	SLICE Ethernet Controller	---	B0B3	---		5/15/2019	5/14/2020
<input checked="" type="checkbox"/> SPS00331	SLICE PRO SIM	18 Analog	A1Q1	600,000	10,000	5/15/2019	5/14/2020
<input type="checkbox"/> SPS00999	SLICE PRO SIM	18 Analog	A1J4	600,000		4/7/2016	4/7/2017
<input checked="" type="checkbox"/> SPT00107	SLICE PRO TOM	4 Squib,8 Digital out	D0L0	1,000,000	10,000	5/15/2019	5/14/2020
<input type="checkbox"/> SPT00999	SLICE PRO TOM	4 Squib,8 Digital out	D0D7	600,000		4/7/2016	4/7/2017

- Selectable DAS Units are SLICE PRO Modules (ECM, SIM, DIM, TOM), SLICE Micro/Nano/IP68 Base/Base+, SLICE/SLICE6/SLICE6 AIR Distributor, TDAS PRO Rack, TDAS G5 or TDAS G5/VDS.
- A DAS system is a SLICE Micro/Nano/IP68 stack, SLICE PRO or TDAS Rack, integrated SLICE/SLICE6 system with a Distributor.

- d. The “Add hardware” option allows new DAS/DAS not present in the database to be manually entered from Test Setups. You can also create generic DAS for temporary use to allow for completing channel assignments. The generic DAS (or any other DAS) can later be replaced using the “Replace hardware” option.

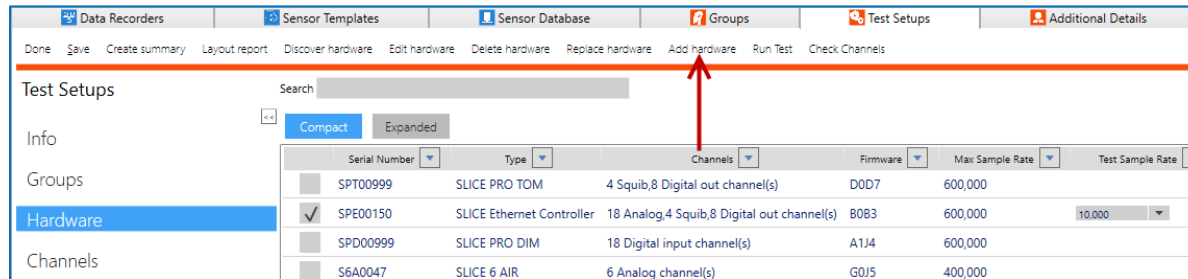

- i. For generic DAS, select the DAS type and configuration (if applicable), then select Save.

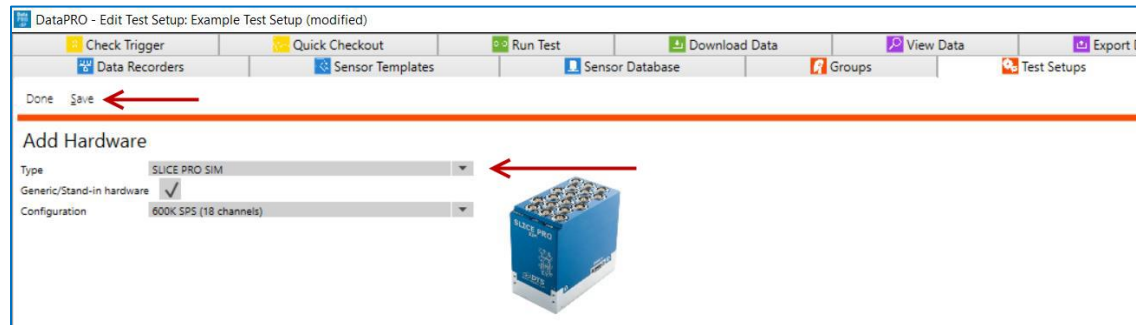

- ii. For new DAS, uncheck the Generic/Stand-in hardware box. Then, enter the serial number and firmware, if known.

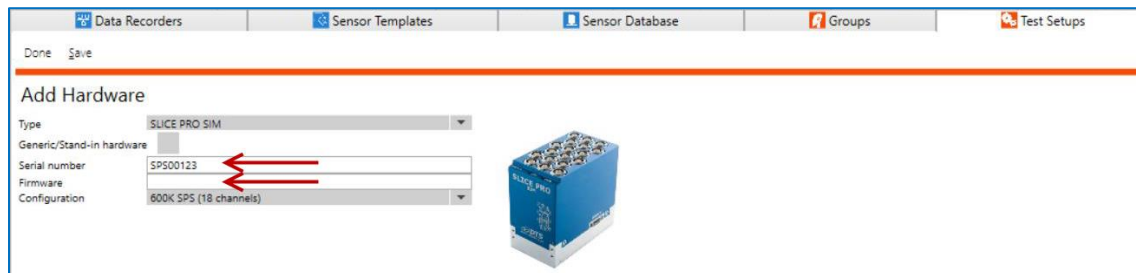

- iii. Firmware will auto-update when connecting to DAS.
- iv. Select Save; the DAS will now be included in the DAS list.

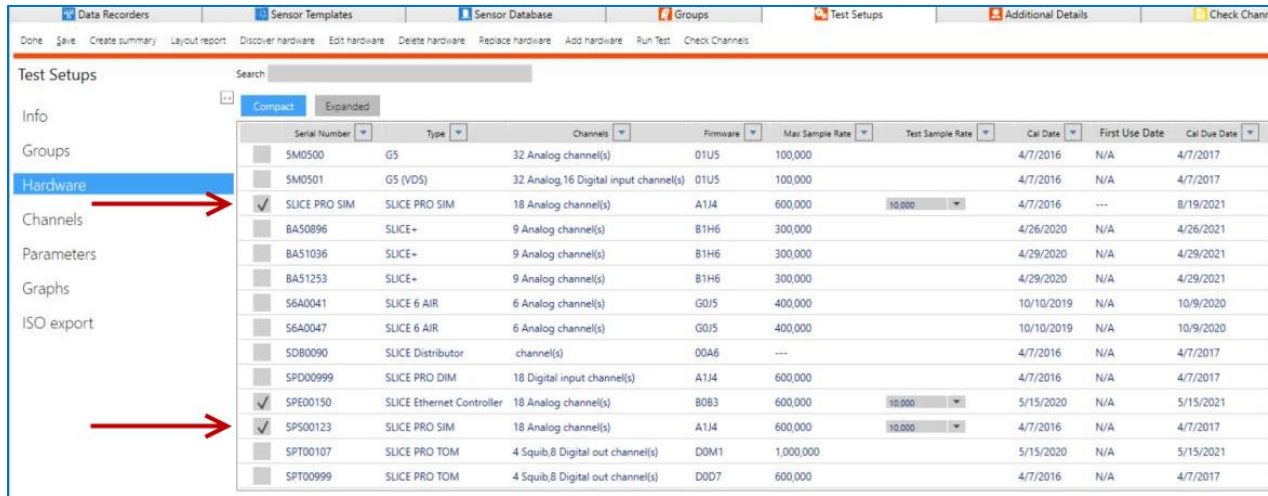

NOTE: Generic DAS will only be available in the Test Setup it was created for.

- e. The “Replace hardware” option allows for the exchange of any hardware, such as a generic DAS, with a different one.

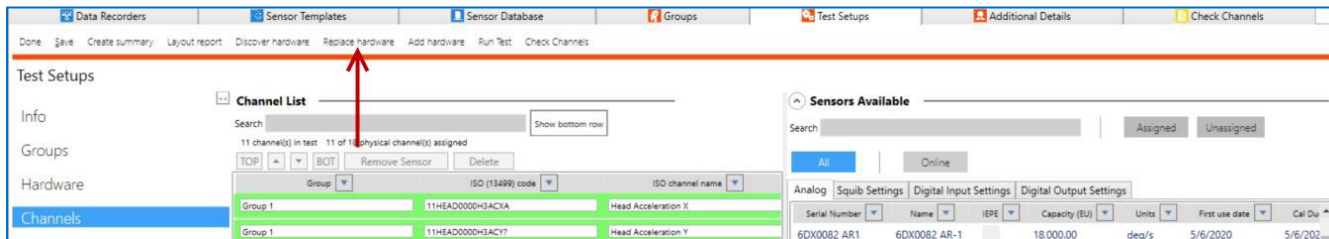

- i. Select the hardware to be replaced in the list on the left, and the hardware to replace it with from the list on the right. Then, select Replace.

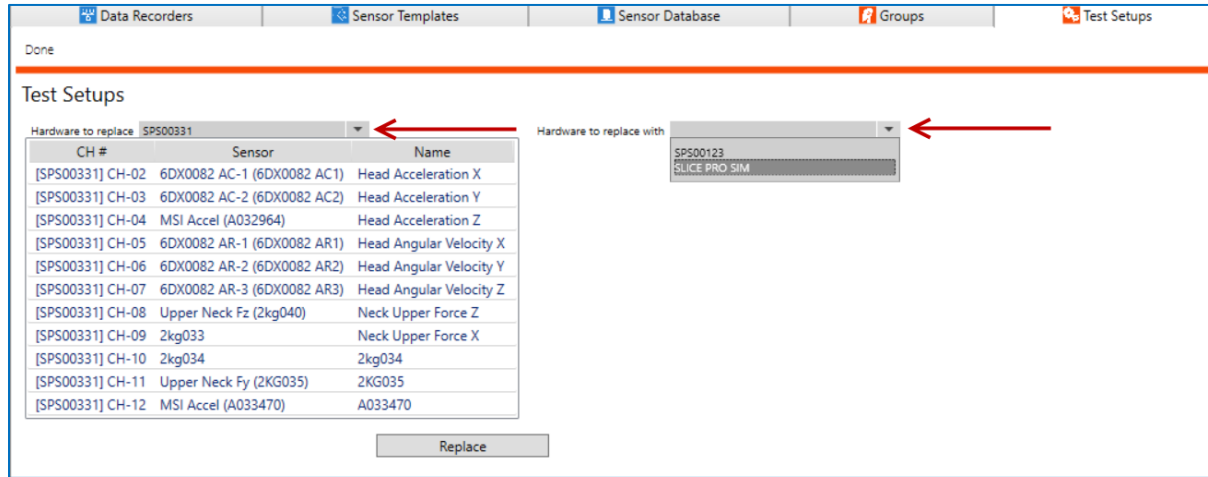

- ii. All channel assignments will be carried to the new hardware.
- f. Hardware which supports it (SLICE6, SLICE6 AIR, and TSR AIR) will have a Clock Master checkbox that allows the device to be set as a clock master for time synchronization.

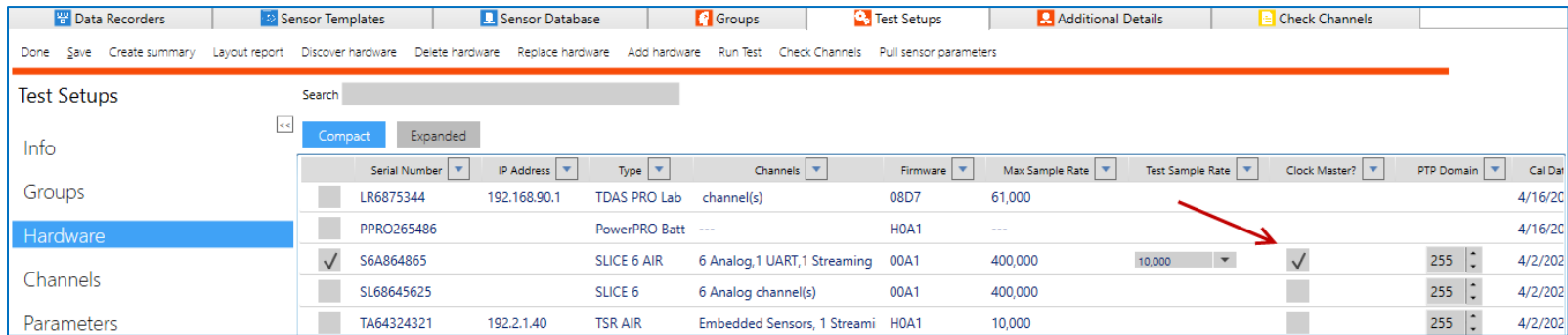

- g. If the test is configured to use the PTP clock type, there will be an additional column for the PTP domain, which can be set from 0 to 255.

Channels

6. The **Channels** navstep lists the sensors and channels included in the Test Setup:

The screenshot shows the DataPRO software interface. The left sidebar has a red arrow pointing to the 'Channels' navstep. The main window is titled 'Test Setup' and contains a 'Channel List' table. The table has columns for 'Group', 'ISO (13499) code', and 'ISO channel name'. Below the table, there are instructions: 'Drag and drop sensors or hardware here to create new channels' and 'Drag a squib or digital output hardware channel to create a squib or digital output setting'. To the right, the 'Sensors Available' section shows a table with columns for 'Serial Number', 'Name', 'IEPE', 'Sensor max range', 'Units', and 'Out Of Date'. The table lists several sensors, including 'Upper Neck Fx', 'Upper Neck Fy', and 'Upper Neck Fz'.

- The controls of the Channels navstep in Test Setup are the same as the controls for the Channels navstep in Group (See [Groups](#), page 66, for more information).

NOTE: DataPRO allows the same sensor to be assigned to multiple channels for more easily building Test Setups prior to sensor placement. Reusable sensor(s) must not have an EID.

Voltage Input Channels

- b. If “Create voltage input channels” is enabled in **System Settings**, dragging an analog hardware channel into a test setup automatically creates a new data channel set up to record voltage input at a gain of 1.
 - If the channel already has a sensor, including an existing voltage input channel, the hardware assignment is changed but not the sensor assignment.
 - When a voltage input channel is created the channel name is given a user channel name and an ISO channel name based on the hardware channel, for example “[S6A0047] CH-03 Voltage”.
 - Pressing Clear in the hardware list removes the channel from the test.
 - Pressing Delete in the channel list deletes the channel.
 - Pressing Remove Sensor unassigns the voltage input setting for the channel, but leaves the hardware channel assigned.
 - In the Parameters navstep (see below), the voltage channel is shown and allows changing the range of the channel. The numeric range allows for a minimum voltage of .1 and has no maximum.
 - The default zero method should be Absolute Zero.

7. The **ROI x Channels** navstep will only be present if there are multiple Regions of Interest included in the Test Setup:

Group Name	ISO Code	ISO Channel Name	Serial Number	Sensor Name	DAS Serial Number	Sample Rate	Display Units	_ROI Period 1	_ROI Period 2
Test channels	10BUMPFRG00ACXB	Bumper Front Center A	BP027	Bridge Plug	SP500331	10000	g	<input checked="" type="checkbox"/>	<input type="checkbox"/>
Test channels	10BUMPFRRT00ACXB	Bumper Front Right AX	BP028	Bridge Plug	SP500331	10000	g	<input checked="" type="checkbox"/>	<input type="checkbox"/>
Test channels	10BUMPFRLT00ACXB	Bumper Front Left AX	BP029	Bridge Plug	SP500331	10000	g	<input checked="" type="checkbox"/>	<input type="checkbox"/>
Group_3	11NECKUP00H3FOX?	Neck Upper Force X	2kg033	Upper Neck Fx	N/A	N/A	g	<input checked="" type="checkbox"/>	<input type="checkbox"/>
Group_3	11NECKUP00H3FOY?	Neck Upper Force Y	2kg034	Upper Neck Fy	SP500331	10000	g	<input checked="" type="checkbox"/>	<input type="checkbox"/>
Group_3	11NECKUP00H3FOZ?	Neck Upper Force Z	2kg035	Upper Neck Fz	SP500331	10000	g	<input checked="" type="checkbox"/>	<input type="checkbox"/>
Group_3	11HEAD0000H3ACX?	Head Accel AX	6DX0082 AC1	6DX0082 AC-1	N/A	N/A	g	<input checked="" type="checkbox"/>	<input type="checkbox"/>
Group_3	11HEAD0000H3ACY?	Head Accel AY	6DX0082 AC2	6DX0082 AC-2	N/A	N/A	g	<input checked="" type="checkbox"/>	<input type="checkbox"/>
Group_3	11HEAD0000H3ACZ?	Head Accel AZ	6DX0082 AC3	6DX0082 AC-3	N/A	N/A	g	<input checked="" type="checkbox"/>	<input type="checkbox"/>
Group_3	11HEAD0000H3AVX?	Head Angular Rate WX	6DX0082 AR1	6DX0082 AR-1	N/A	N/A	deg/s	<input checked="" type="checkbox"/>	<input type="checkbox"/>
Group_3	11HEAD0000H3AVY?	Head Angular Rate WY	6DX0082 AR2	6DX0082 AR-2	N/A	N/A	deg/s	<input checked="" type="checkbox"/>	<input type="checkbox"/>
Group_3	11HEAD0000H3AVZ?	Head Angular Rate WZ	6DX0082 AR3	6DX0082 AR-3	N/A	N/A	deg/s	<input checked="" type="checkbox"/>	<input type="checkbox"/>

- a. Select channels to be included in each ROI segment.
- b. Selection can be modified prior to ROI Download.
- c. Every channel must be included in at least one ROI segment.

Parameters

8. The **Parameters** navstep allows for modifications to certain channel parameters. These changes apply only to the **Test Setup**. Select channel type to display with sub navsteps (See [Appendix A: Common Sensor Types and Bridge Connections](#), page 249, for more information about different sensor types and options during sensor entry).

a. Analog Channels:

ie	Sensor (SN)	Channel full-scale	Sensor max range	Sensitivity	Units	Channel filter class	Polarity	Zero Method	Start (sec)	End (sec)	Initial offset
X	Bridge Plug (BP027)	2,000.00	2,000.00	0.02000000 mV/V/EU	g	CFC 600 (B)	+	Avg over time	-0.05000	-0.02000	None
	Bridge Plug (BP028)	2,000.00	2,000.00	0.02000000 mV/V/EU	g	CFC 600 (B)	+	Avg over time	-0.05000	-0.02000	None
	Bridge Plug (BP029)	2,000.00	2,000.00	0.02000000 mV/V/EU	g	CFC 600 (B)	+	Avg over time	-0.05000	-0.02000	None
	Upper Neck Fx (2kg033)	1,000.00	2,000.00	0.00042000 mV/V/EU	g	CFC 1000 (A)	+	Avg over time	-0.05000	-0.02000	None
	Upper Neck Fx (2kg034)	1,000.00	2,000.00	0.00042000 mV/V/EU	g	CFC 1000 (A)	+	Avg over time	-0.05000	-0.02000	None
	Upper Neck Fy (2kg035)	1,000.00	2,000.00	0.00040500 mV/V/EU	g	CFC 1000 (A)	-	Avg over time	-0.05000	-0.02000	None
	6DX0082 AC-1 (6DX0082 AC1)	2,000.00	2,000.00	0.01755000 mV/V/EU	g	CFC 1000 (A)	+	Avg over time	-0.05000	-0.02000	EU
	6DX0082 AC-2 (6DX0082 AC2)	2,000.00	2,000.00	-0.01700000 mV/V/EU	g	CFC 1000 (A)	+	Avg over time	-0.05000	-0.02000	
	6DX0082 AC-3 (6DX0082 AC3)	2,000.00	2,000.00	0.01825000 mV/V/EU	g	CFC 1000 (A)	-	Avg over time	-0.05000	-0.02000	
	6DX0082 AR-1 (6DX0082 AR1)	300.00	18,000.00	0.09440000 mV/EU	deg/s	CFC 1000 (A)	+	Avg over time	-0.05000	-0.02000	
	6DX0082 AR-2 (6DX0082 AR2)	300.00	18,000.00	0.09370000 mV/EU	deg/s	CFC 1000 (A)	+	Avg over time	-0.05000	-0.02000	
	6DX0082 AR-3 (6DX0082 AR3)	300.00	18,000.00	-0.09456000 mV/EU	deg/s	CFC 1000 (A)	-	Avg over time	-0.05000	-0.02000	

- i. Modify Channel full-scale capacity, Channel Filter Class, Polarity, Software Zero Method, Average Over Time Start/End and Initial Offset for individual Analog channels.
- ii. Low g channels for TSR AIR devices additionally have an option to enable AC coupling (See [Appendix J: TSR AIR Setup](#), page 342).
- iii. Select Modify Global Range CAC to modify the range for all Analog Channels based on High, Medium, Low Range and Capacity settings in Sensor Database.

NOTE: If “Allow push/pull of sensors” is enabled, any difference from the Sensor Database will be indicated in orange. See [System Settings](#), page 210, for more information.

b. Squib Channels:

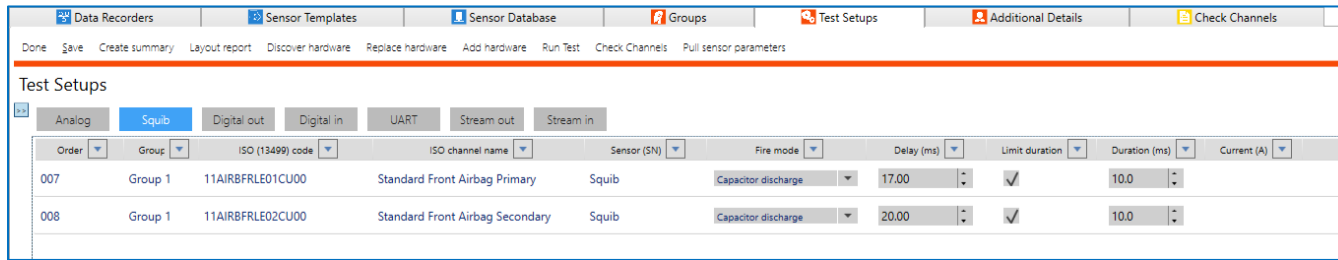

- i. Modify Fire Mode, Delay, Limit Duration, Duration and Current (if applicable based on fire mode).

c. Digital Output Channels:

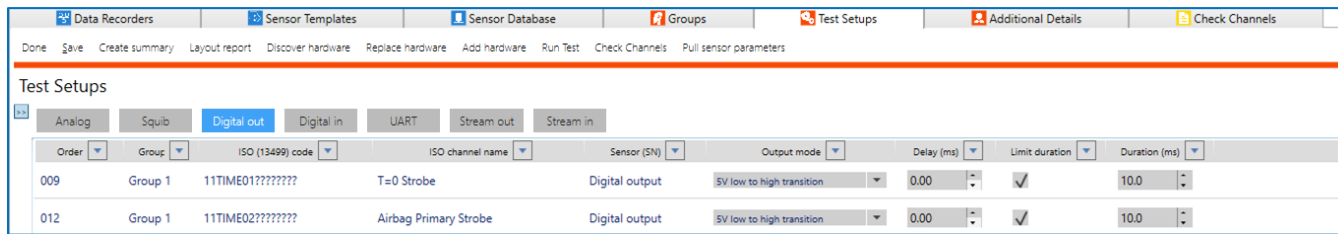

- i. Modify Output mode, Delay, Limit duration and Duration.

d. Digital Input Channels:

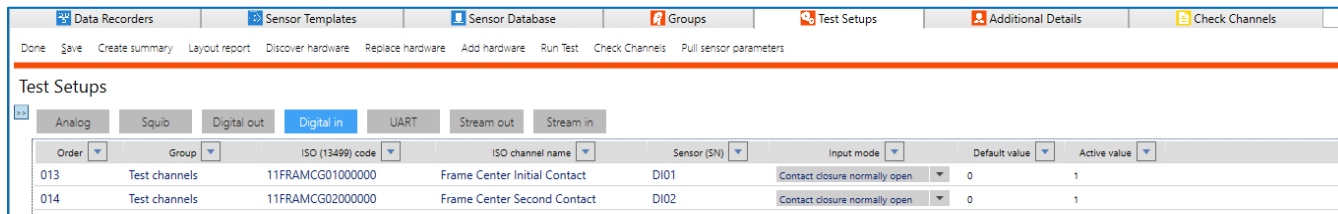

- i. Modify Input mode, Default Value and Active Value.

e. UART Channels:

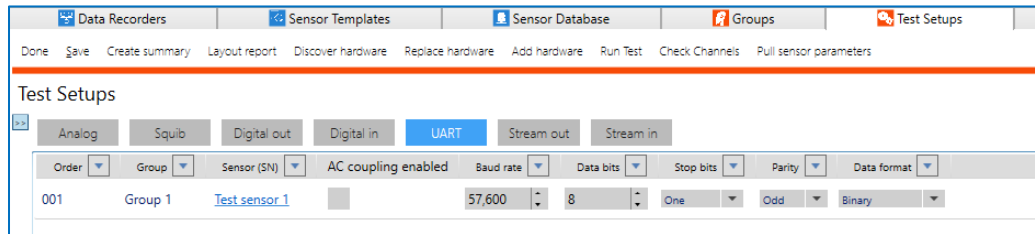

- i. Modify AC coupling enabled, Baud rate, Data bits, Stop bits, Parity, and Data format.

f. Stream Output Channels:

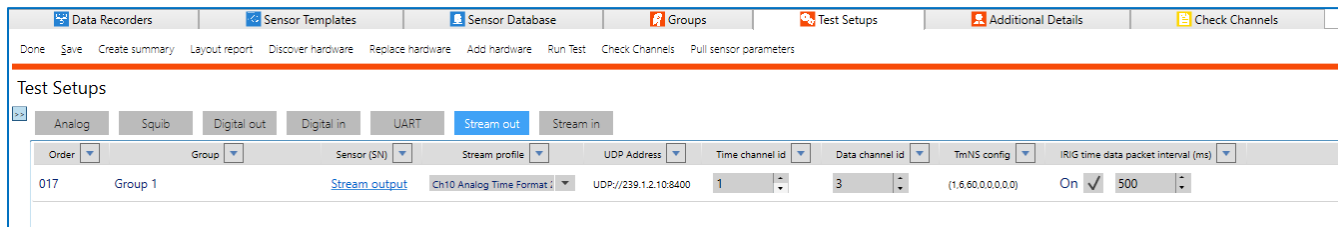

- i. Modify Stream profile and other parameters depending on the selected profile, including UDP Address, Time channel id, Data channel id, TmNS config, IRIG time data packet interval, Subframe Id, Message Id, Minor per major, TMATS port, TMATS interval, Source port, and IENA key.

i.

g. Stream Input Channels:

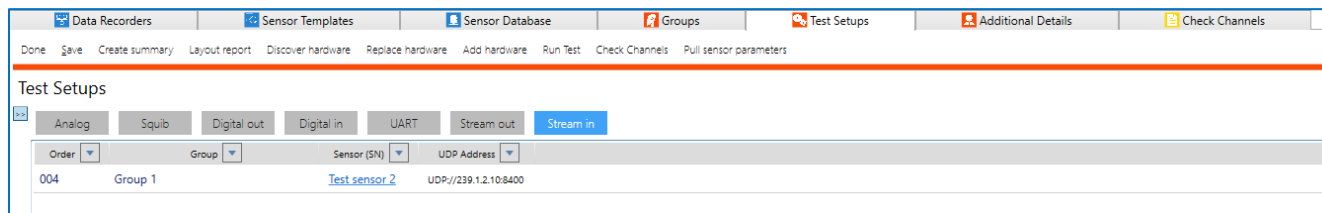

- i. Modify UDP Address.

Level Triggers

9. In order to designate a channel as a **Level Trigger**, the “Enable level-trigger UI” checkbox must be checked in System Settings (See [System Settings](#), page 210, for more information). Level Triggers are also available when configuring a test containing a TSR AIR device using the Active recording mode. See [Appendix J: TSR AIR Setup](#), page 344, for TSR AIR specific configuration.

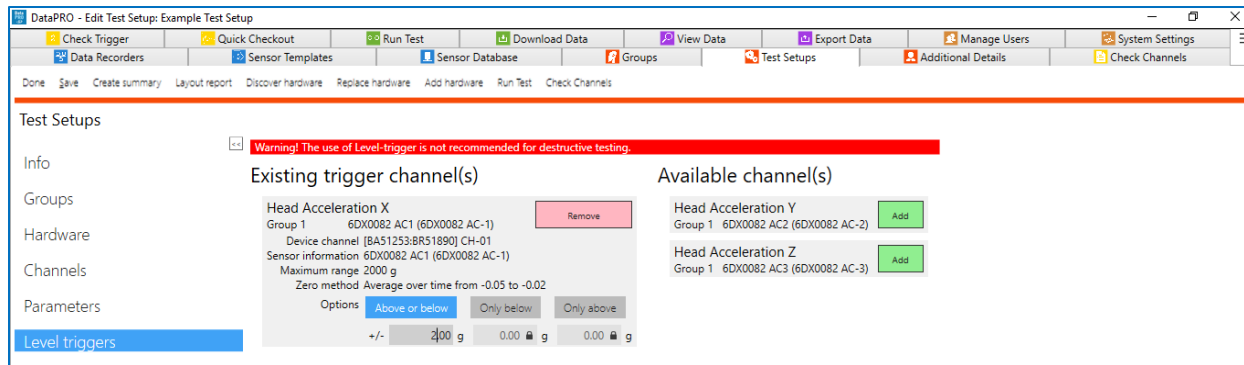

- a. A level trigger will initiate data collection or mark T=0 when a predetermined sensor threshold is exceeded. Five (5) consecutive samples at or above the specified threshold is required for the level trigger to be considered valid.
- b. Only channels with hardware channel assignments will be listed as Available channels to designate as a level trigger.
 - i. Channels must be manually assigned to a hardware channel or discovered by EID in order to be listed as an Available channel.

NOTE: *DTS does not recommend using a level trigger for destructive testing.*

NOTE: *When using level triggers, allow adequate time for sensors to warm up before performing a diagnostic checkout, as sensors may drift from the measured zero level.*

- c. To designate a channel as a level trigger, select Add.
- d. Select Triggering option (Above or below, Above only, or Below only).
 - i. Available triggering options depend on hardware connection.

- e. Enter trigger threshold value.
- f. Select Save to save level trigger to Test Setup.

10. In order to add **Calculated Channels** to a Test Setup, the “Allow calculated channels” checkbox must be checked in System Settings (See [System Settings](#), page 210, for more information). Calculated channels can also be added in the data viewer.

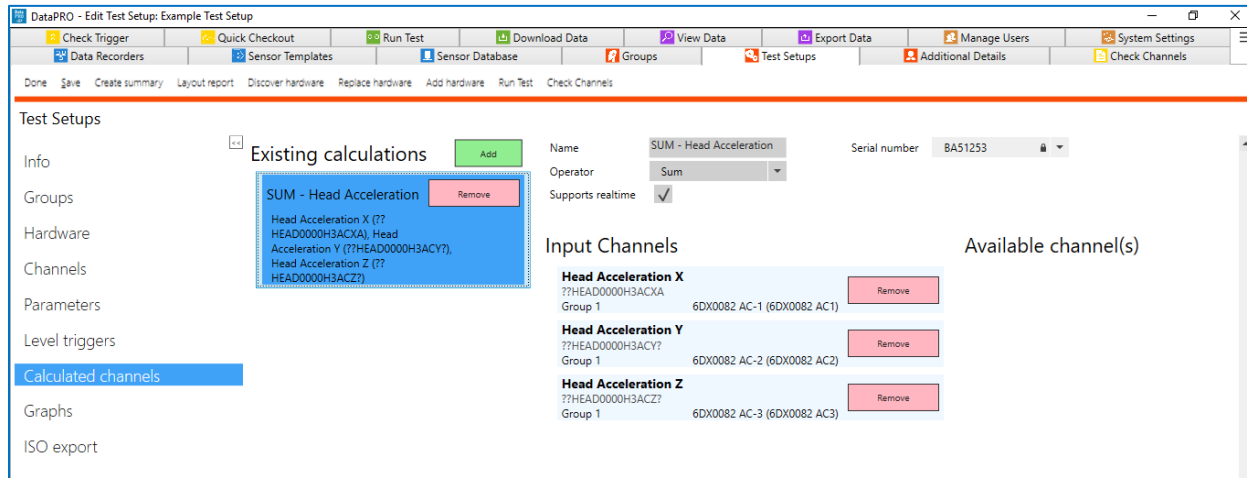

NOTE: Only channels with hardware channel assignments will be listed as Available channel(s).

NOTE: All input channels must be assigned to the same DAS.

- a. Select Add to add a calculated channel.
- b. Enter name for calculated channel.
- c. Choose calculated channel type from Operator drop-down.
- d. Select DAS from Serial Number drop-down.
- e. Select channels to include in calculation from Available channel(s).
- f. Select Calculated channel from Existing calculations to display Input Channels.
- g. Enable “Supports Realtime” to view the calculated channel in Realtime.

Graphs

11. The **Graphs** navstep allows configuring pre-defined channel overlays for post-test data viewing. Channel overlays can also be added in the data viewer:

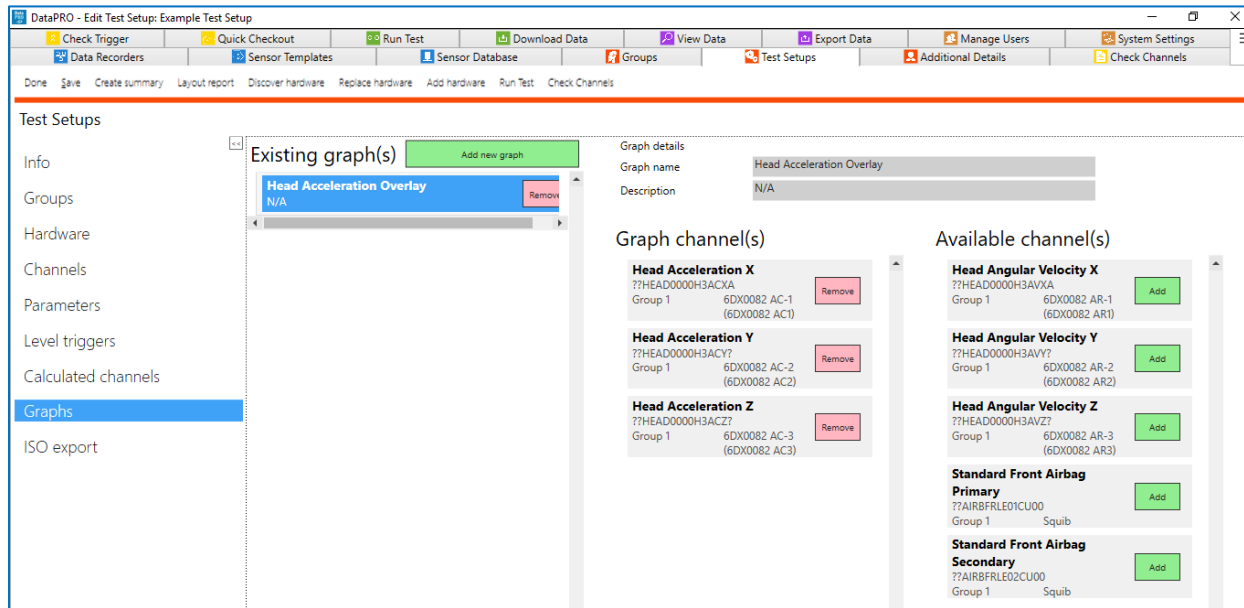

- a. To add an overlay graph, select Add new graph.
- b. Enter Graph name and optional Description.
- c. Select channels to include in the graph overlay from Available Channels.
- d. Select Existing graph to display included Graph channels.

ISO Export

12. ISO Export:

Key	Value
Test Operator	R. Smith
Test Conditions	Ideal

Test objects	Comments	test object details
1 Group 1	Comments of test object '1' Comments of test object '1' Comments of test object '1'	Name of test object '1': NOVALUE Velocity test object '1': [red box] m/sec Mass test object '1' (kg): [red box]

- Enter preliminary metadata required for ISO MME export.
- ISO Export metadata can be entered in the Info navstep of Run Test, as well as before each data export. All metadata must be entered in order for the ISO Export to run.
- Enter optional Extra Properties under Test Settings or Test Objects as desired.

13. Select "Save" when finished:

Done Save Create summary Layout report Discover hardware Replace hardware Add hardware Run Test Check Channels

a. Once a Test Setup is saved, “Run Test” and “Check Channels” are enabled as options:

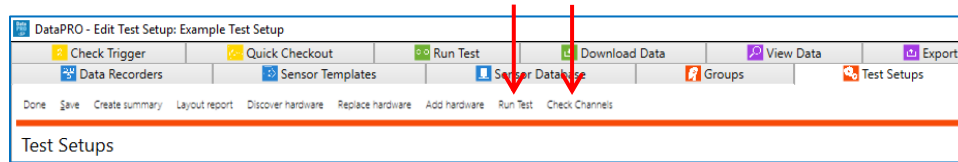

- i. Select Run Test to go directly to the Run Test tab and begin a data collection with the current Test setup.
- ii. Select Check Channels to go directly to the Check Channels tab and begin a Diagnostic test with the current Test Setup.

Edit

14. To edit a test setup, double-click on the test setup –or– select the test setup and select “Edit” (see steps 4-13):

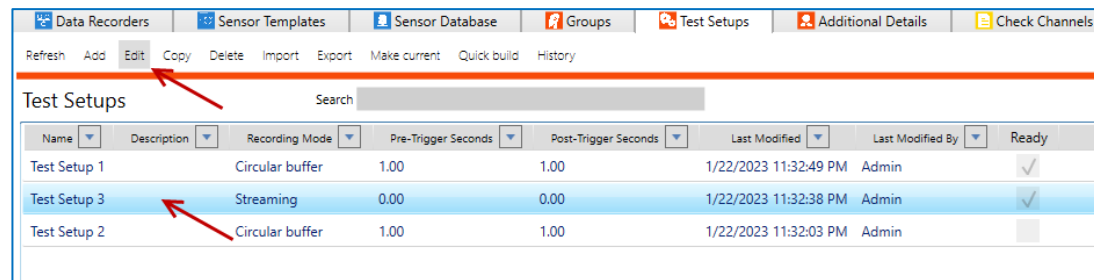

Copy

15. To Copy a test setup, select “Copy” from the menu:

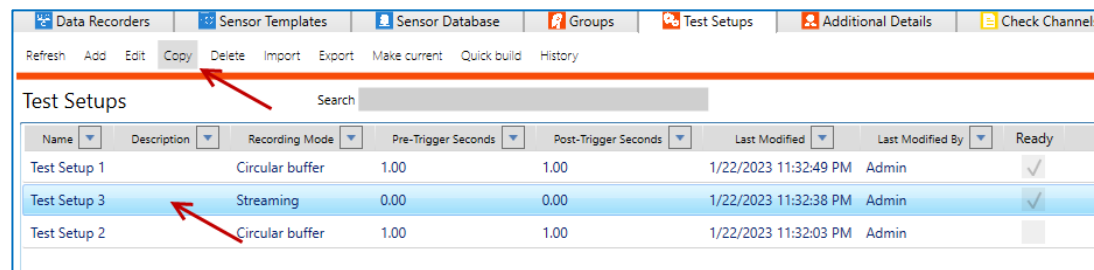

- a. All groups, hardware and test parameters will be copied.
- b. Enter a unique Test Setup name and select Save:

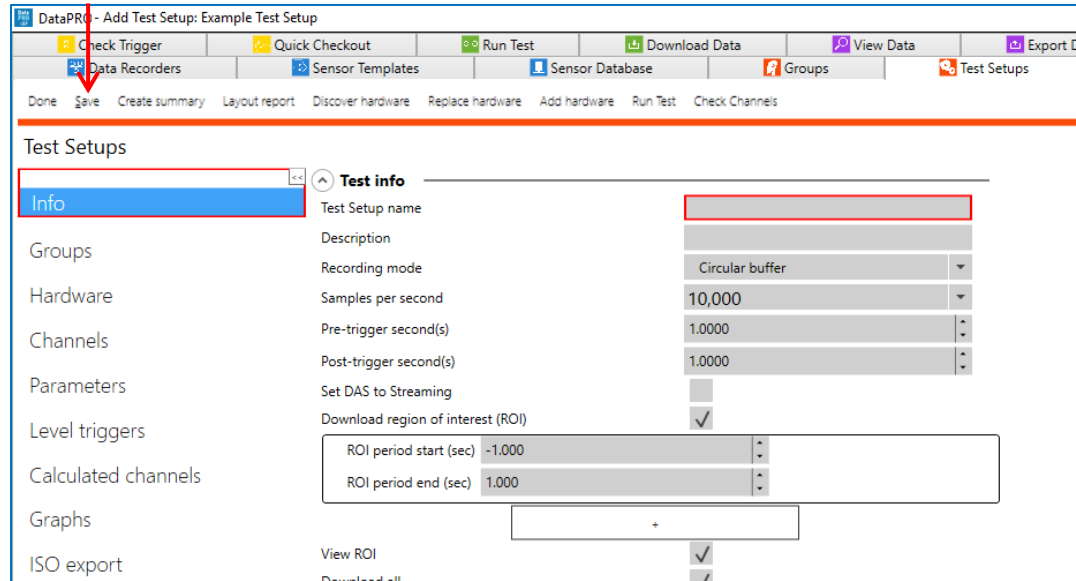

Delete

16. To delete a test setup from the database, select the test setup from the list, select “Delete” and then “Yes” to confirm:

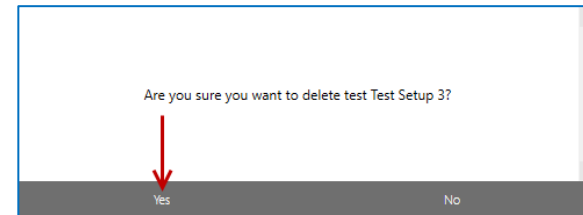
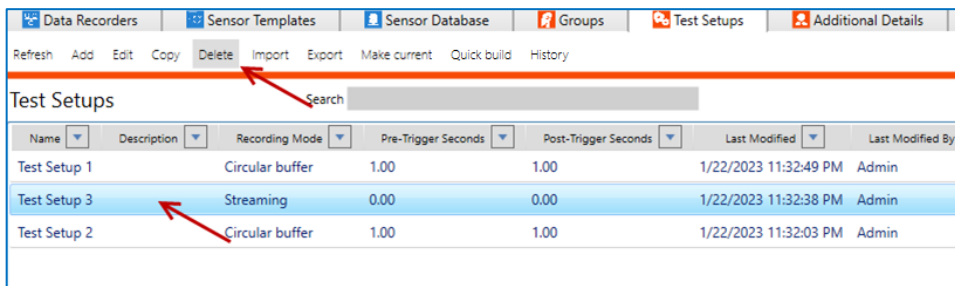

Import

17. To import a test setup, select “Import” from the menu.

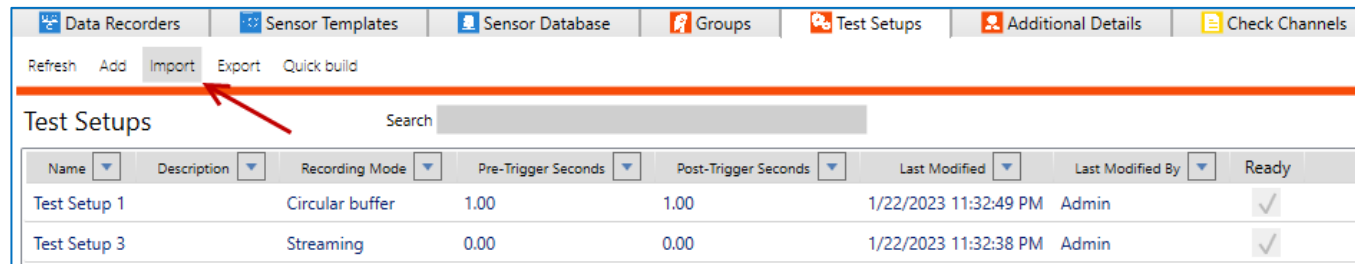

NOTE: The import performed in this manual uses a DataPRO Test Setup XML. There are multiple format options for a Test Setup import. The format option selected will dictate the files available for selection. Some import types require additional files; see table below for more details regarding import type requirements.

NOTE: Some imports add new sensors and DAS to the database, and some require that all items in the import exist in the database prior to import.

Test Setup Import Requirements

Type	Additional Files Required	Options	Database Requirements
DataPRO XML	None	Multiple test setups can be imported with one *.xml file	Additional sensors and DAS will be added to database
TDC Test Setup File (*.tsf)	*.ini	All hardware used in the *.tsf must be in the database	Additional sensors will be added to database, all DAS must be in database
DataPRO Test Sensor Import File (*.csv)	None	System Settings option to create static groups from imported groups	Additional sensors will be added to database
TTS (*.csv, *.xml)	None	Customer specific import	All sensors and DAS must be in database

18. Browse to select the file, and then select “Open”.

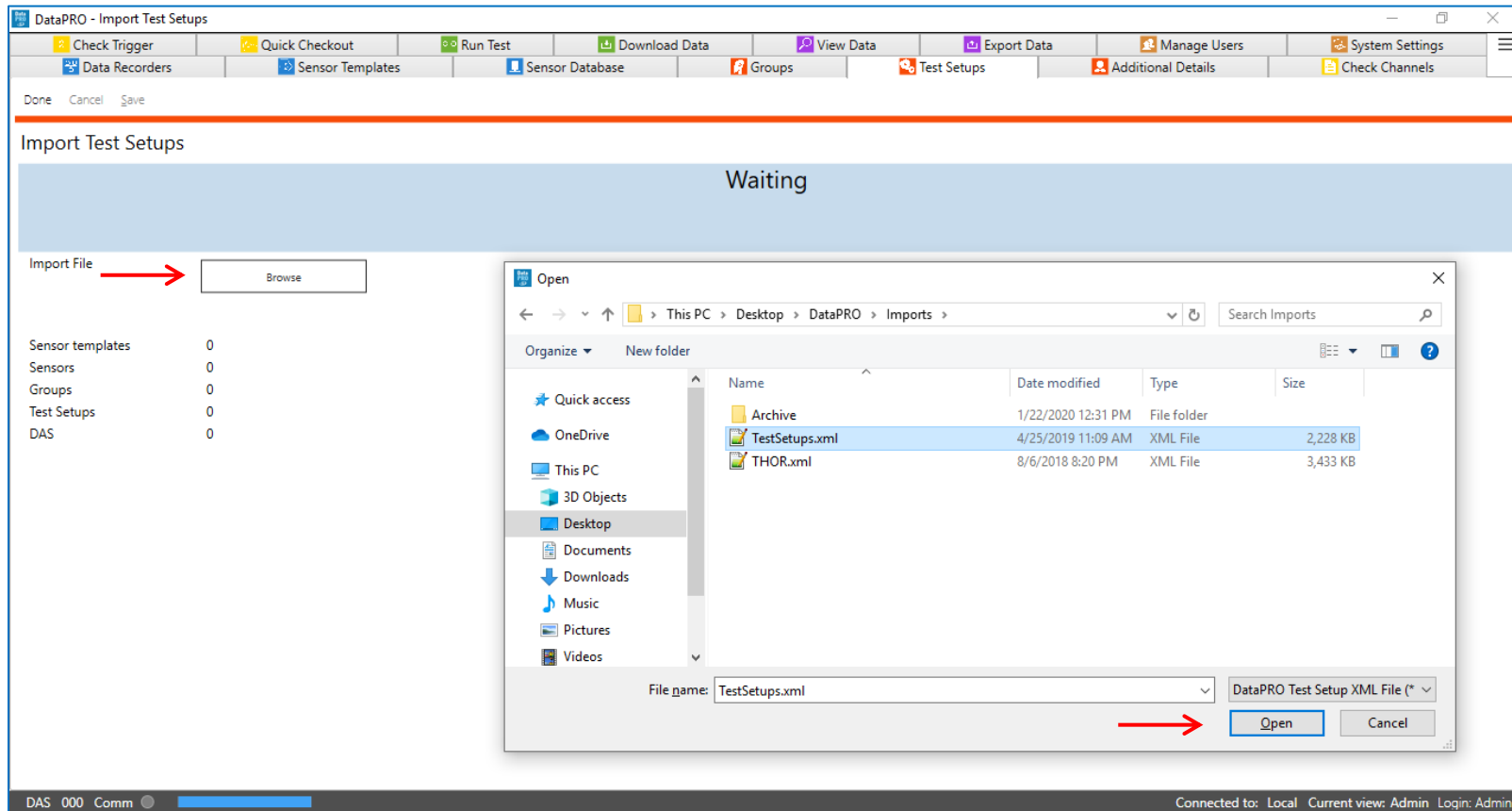

a. Select the Test Setup(s) to be imported:

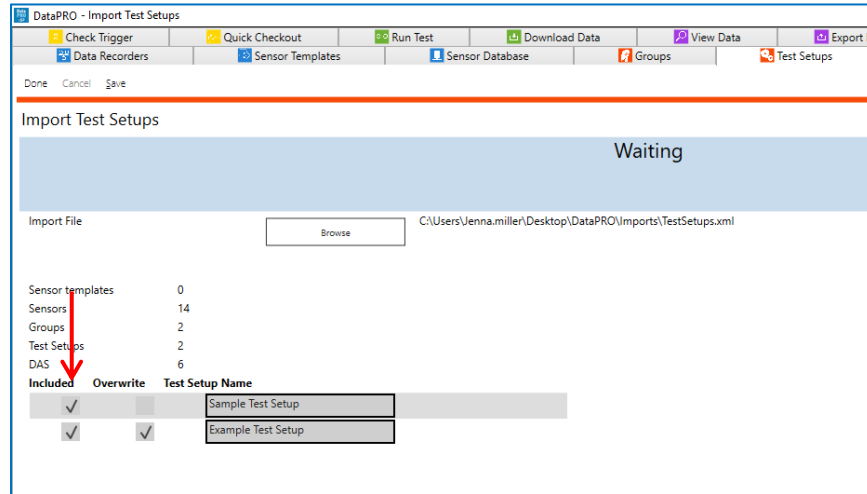

- i. “Red Boxed” Test Setups indicate a naming conflict.
- ii. Either select Overwrite, or change duplicate name(s) to import any test setups with naming conflicts.

b. Select Save once all conflicts are resolved. Select Done when import is complete:

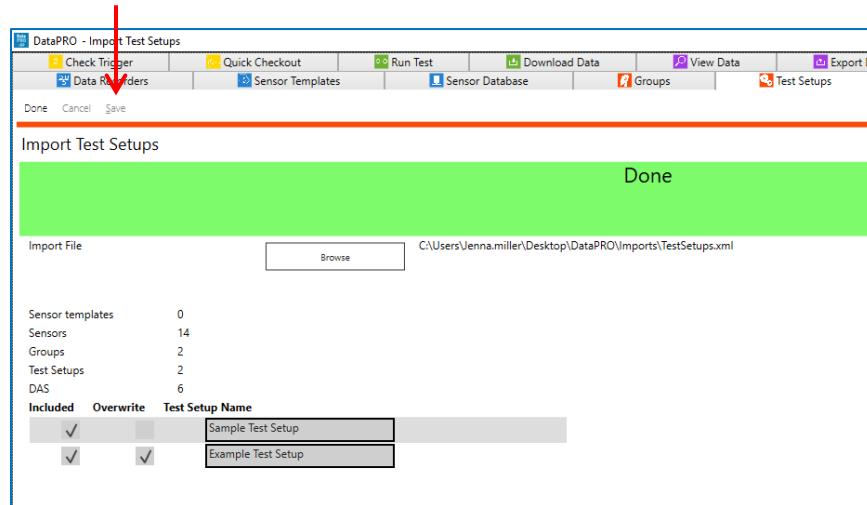

Export

19. To export a test setup, select “Export” from the menu:

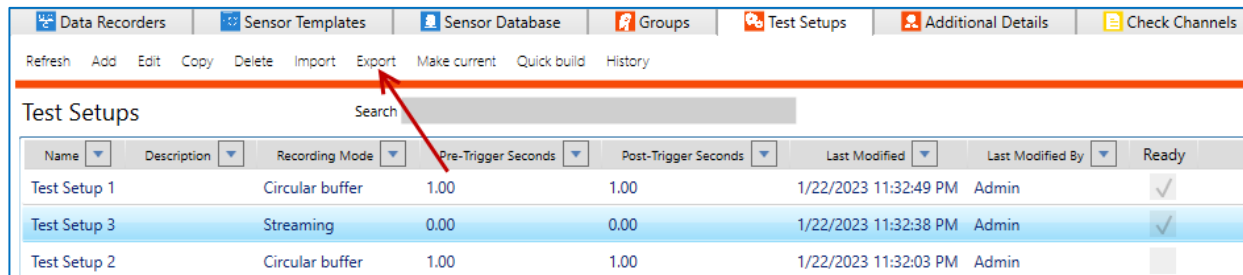

a. Select the test(s) to be exported and select “Browse”. Select “Export”.

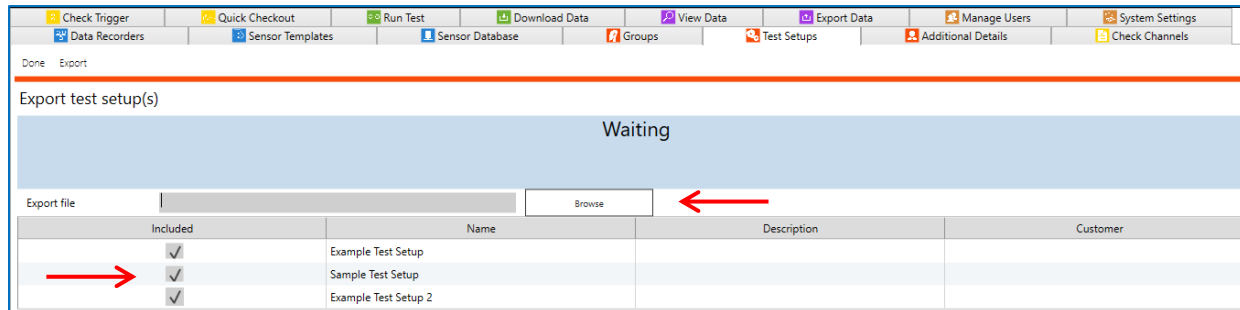

b. Navigate to the desired location, enter a name for the test setup export file and select “Save”.

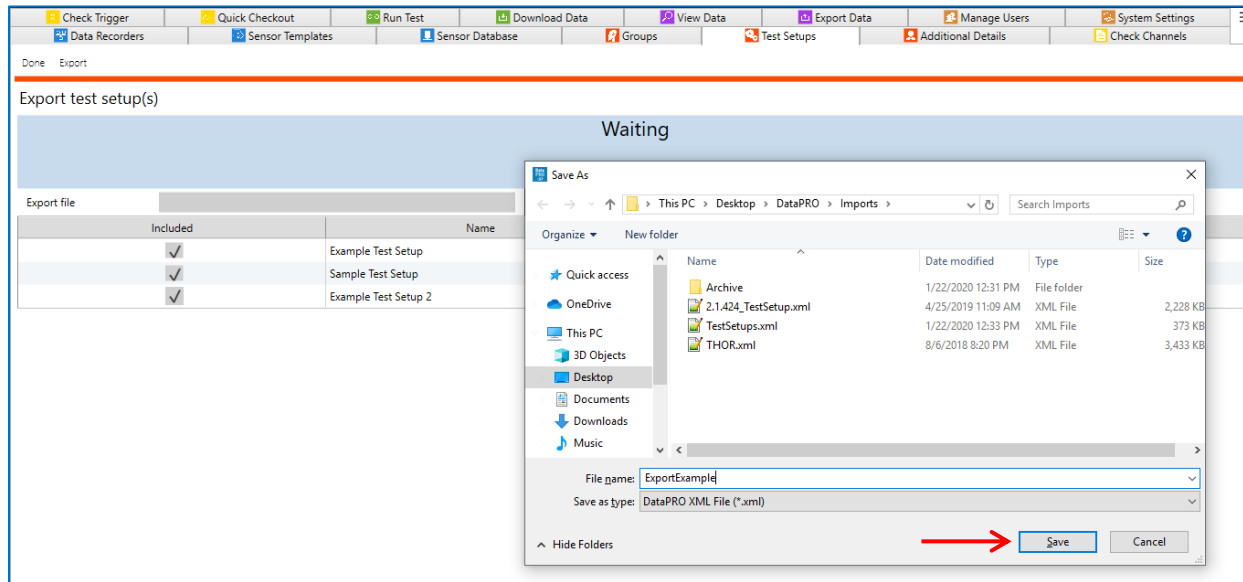

c. Select “Export”.

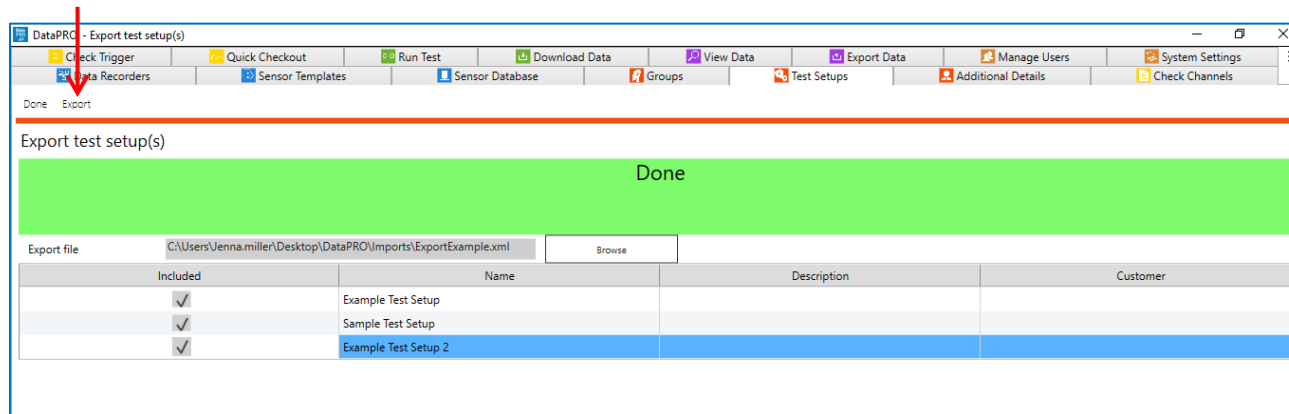

d. Select “Done” when finished.

Quick Build

20. The Quick Build menu option allows you to quickly build a test setup, given DAS that has been used previously in a test.

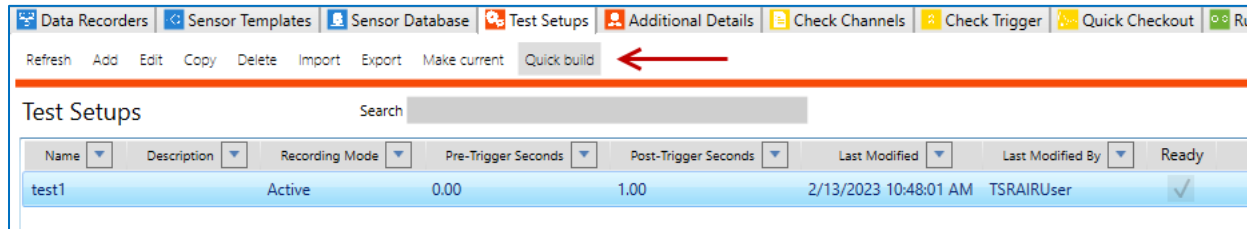

- Quick Build is only available if it has been enabled in System Settings -> Test Settings -> Allow Quick Build.
- From the Quick Build screen, you may connect to DAS from UDP discovery using the AutoDiscovery toggle, by manually entering IP addresses, or by selecting hardware from the Available DAS list at the bottom of the screen.

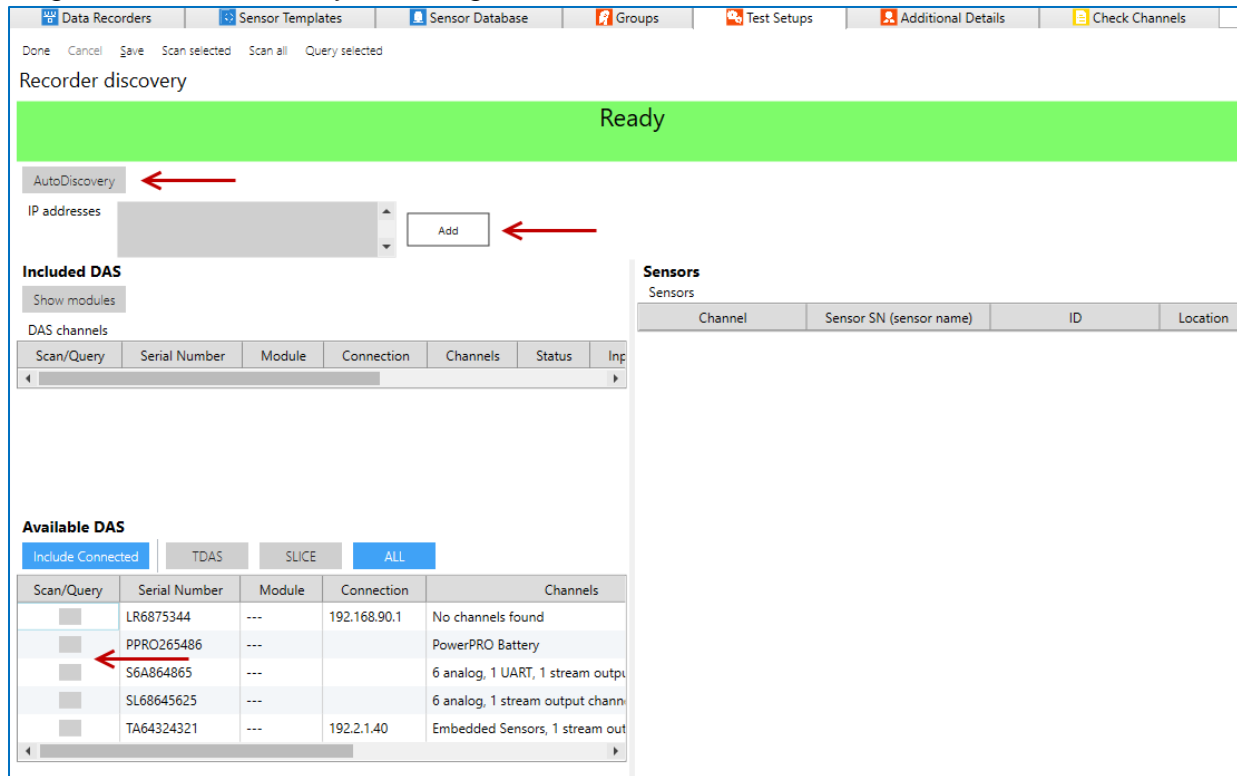

- c. Choose Scan All or Scan Selected to ping devices. If AutoDiscovery is toggled on, scanning will do UDP discovery of devices on the network.
- d. Select the desired DAS from the Included DAS list.
- e. Select Query Selected to connect to the detected devices and gather sensor information.
- f. Any electronic IDs (EIDs) on the DAS will be shown under Sensors, as well as any sensors that were on the DAS the last time it was used to collect data.

The screenshot shows the software interface with the following sections:

- Recorder discovery:** A green bar at the top indicates the status is "Done". A red arrow points to the "Query selected" button in the menu bar.
- Included DAS:** A table listing discovered devices. A red arrow points to the checkmark in the "Scan/Query" column of the first row.
- Sensors:** A table listing sensors found on the selected DAS. A red arrow points to the first row of the table.

Scan/Query	Serial Number	Module	Connection	Channels	Status	Input
<input checked="" type="checkbox"/>	SPS0021	---	USB	18 analog cha	Connected	12.6 V

Channel	Sensor SN (sensor name)	ID	Location
DTS Scale LC	2KG005(DTS Scale LC)	DC00000126A7CF2D	Assigned by ID

g. Build Test Setup creates a test setup based on the test that was detected on any DAS queried.

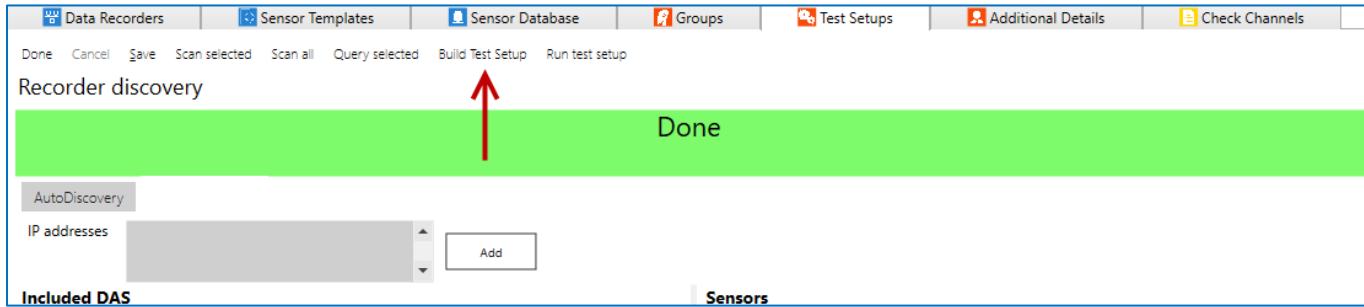

h. Run Test Setup starts running a test based on the test that was detected on any DAS queried, and will jump to the Check Sensor Ids step of Run Test.

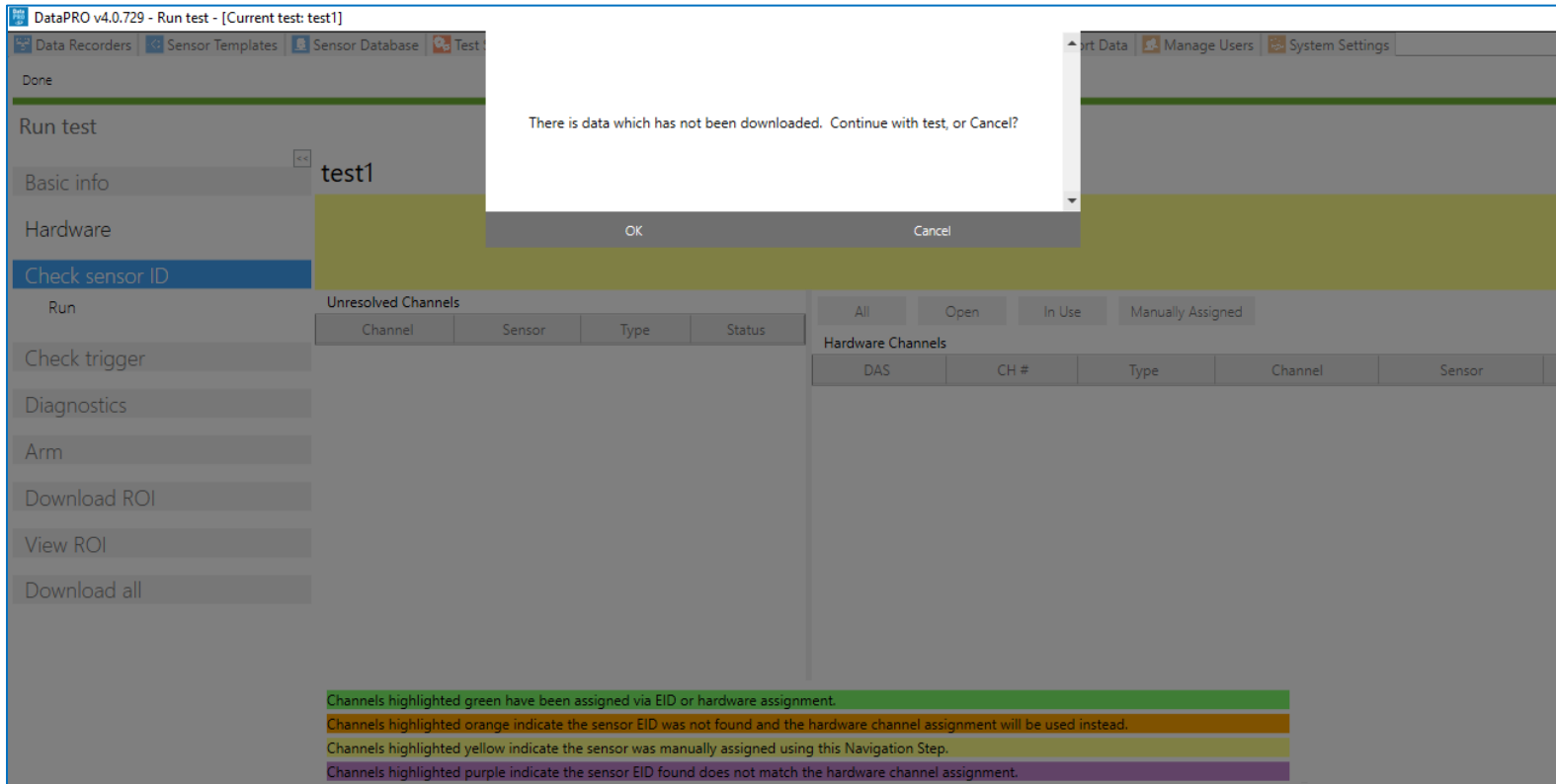

Change Test Setup

21. To change the active Test Setup, select the desired test setup and select “Make Current”:

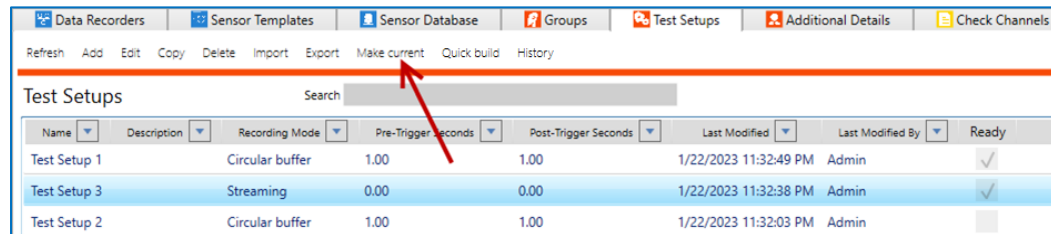

Name	Description	Recording Mode	Pre-Trigger Seconds	Post-Trigger Seconds	Last Modified	Last Modified By	Ready
Test Setup 1		Circular buffer	1.00	1.00	1/22/2023 11:32:49 PM	Admin	✓
Test Setup 3		Streaming	0.00	0.00	1/22/2023 11:32:38 PM	Admin	✓
Test Setup 2		Circular buffer	1.00	1.00	1/22/2023 11:32:03 PM	Admin	

- a. A test must be indicated as “Ready” in order to be designated as the Current Test Setup.
- b. The Current Test Setup will be displayed in brackets in the DataPRO header bar:

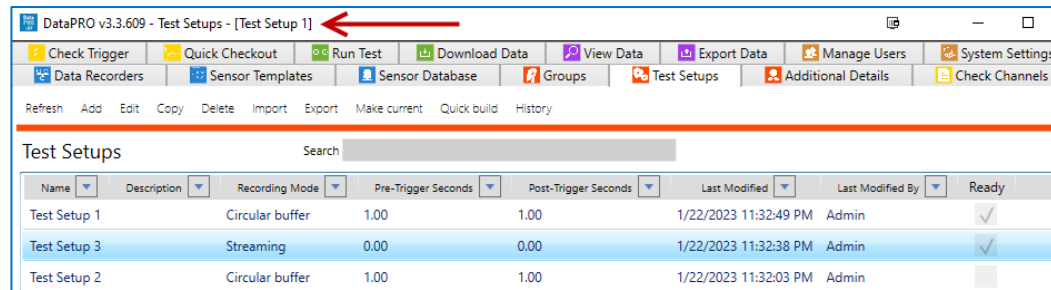

Name	Description	Recording Mode	Pre-Trigger Seconds	Post-Trigger Seconds	Last Modified	Last Modified By	Ready
Test Setup 1		Circular buffer	1.00	1.00	1/22/2023 11:32:49 PM	Admin	✓
Test Setup 3		Streaming	0.00	0.00	1/22/2023 11:32:38 PM	Admin	✓
Test Setup 2		Circular buffer	1.00	1.00	1/22/2023 11:32:03 PM	Admin	

Refresh

22. If using a SQL Server Networked Database, use Refresh to ensure the latest test setup settings are used:

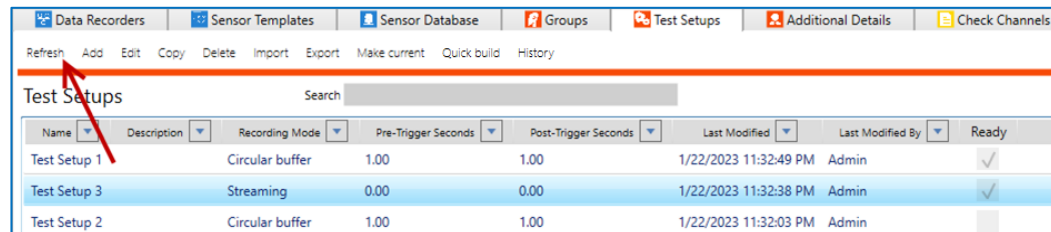

Name	Description	Recording Mode	Pre-Trigger Seconds	Post-Trigger Seconds	Last Modified	Last Modified By	Ready
Test Setup 1		Circular buffer	1.00	1.00	1/22/2023 11:32:49 PM	Admin	✓
Test Setup 3		Streaming	0.00	0.00	1/22/2023 11:32:38 PM	Admin	✓
Test Setup 2		Circular buffer	1.00	1.00	1/22/2023 11:32:03 PM	Admin	

Layout Report

23. The Layout Report option allows you to generate the same layout report that is run during the Run Test step, at any point prior to running the test. One report is generated for each DAS included in the test. The report contains the sensor serial number, hardware channel connection, sensitivity, filter and excitation voltage. ISO Code, level trigger parameters, squib fire mode, delay and duration are also recorded if applicable to the channel.

a. Select Layout Report from the active, open Test Setup.

The screenshot shows the Data Recorder software interface. The top menu bar includes 'Data Recorders', 'Sensor Templates', 'Sensor Database', 'Groups', 'Test Setups', 'Additional Details', and 'Check Channels'. Below the menu bar, there is a toolbar with options: 'Done', 'Save', 'Create summary', 'Layout report', 'Discover hardware', 'Replace hardware', 'Add hardware', 'Run Test', 'Check Channels', and 'Pull sensor parameters'. The 'Layout report' option is highlighted with a red arrow. The main window is divided into several sections: 'Test Setups' (left sidebar), 'Channel List' (center), 'Sensors Available' (right), and 'Hardware' (bottom right). The 'Channel List' section shows a table of channels with columns for 'code', 'ISO channel name', 'Type', and 'Sensor (SN)'. The 'Sensors Available' section shows a table of sensors with columns for 'Serial Number', 'Name', 'IEPE', 'Capacity (EU)', 'Units', and 'First use date'. The 'Hardware' section shows a table of hardware components with columns for 'DAS', 'CH #', 'Type', and 'Channel'.

b. The excel file generated can be found in the below location, organized by DAS serial number.

C:/DTS/DTS.Suite/Version/DataPRO/TEMP/Reports

24. To return to the Quick Start steps, go back to page 32.

Additional Details

Lab Details

Exporting data for “Lab Details” is a required component of following ISO MME protocol. Completing “Lab Details” is optional for use with data exports.

1. Select the “Additional Details” tab:



2. Select the Lab details navstep and enter the information for each Lab Record:

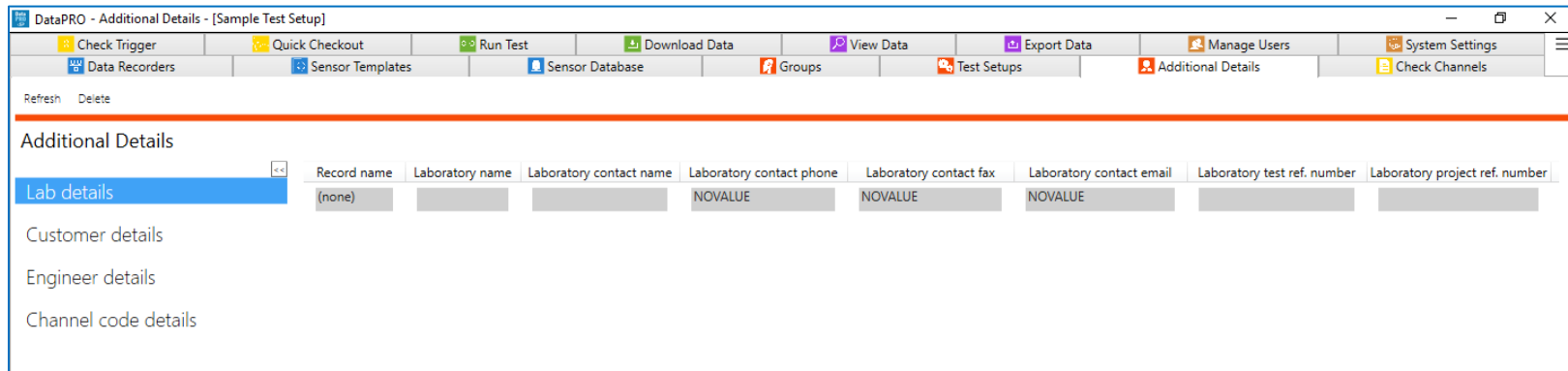

Record name	Laboratory name	Laboratory contact name	Laboratory contact phone	Laboratory contact fax	Laboratory contact email	Laboratory test ref. number	Laboratory project ref. number
(none)			NOVALUE	NOVALUE	NOVALUE		

- a. This information can be modified before exporting data.
- b. Records are automatically saved.

3. To delete a Lab Details Record, select the record from the list and select Delete:

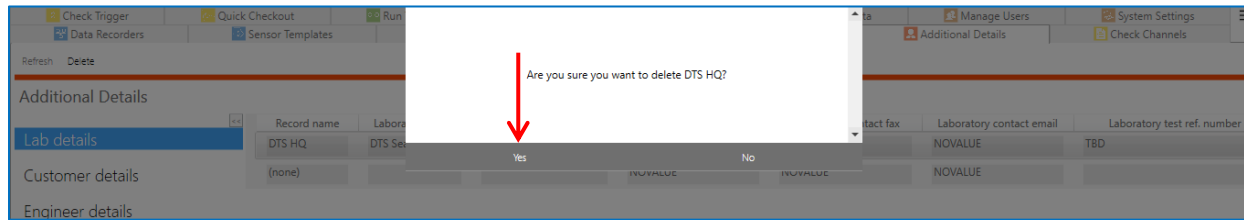

4. To return to the **Quick Start** steps, go back to page 32.

Customer Details

Exporting data for Customer Details is a required component of following ISO MME protocol. Completing Customer Details is optional for use with data exports.

1. Select the “Additional Details” tab.
2. Select the Customer details navstep and enter the information for each Customer Record:

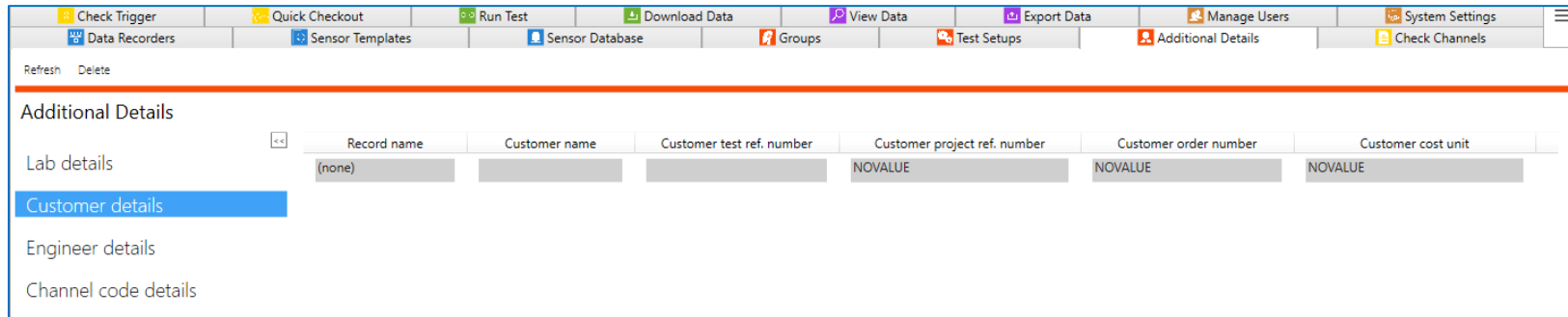

- a. This information can be modified before exporting data.
 - b. Records are automatically saved.
3. To delete a Customer Details Record, select the record from the list and select Delete.
 4. To return to the **Quick Start** steps, go back to page 32.

Engineer Details

Exporting data for “Engineer Details” is a required component of following ISO MME protocol. Completing “Engineer Details” is optional for use with data exports.

1. Select the “Additional Details” tab.
2. Select the Engineer details navstep and enter the information for each Engineer Record:

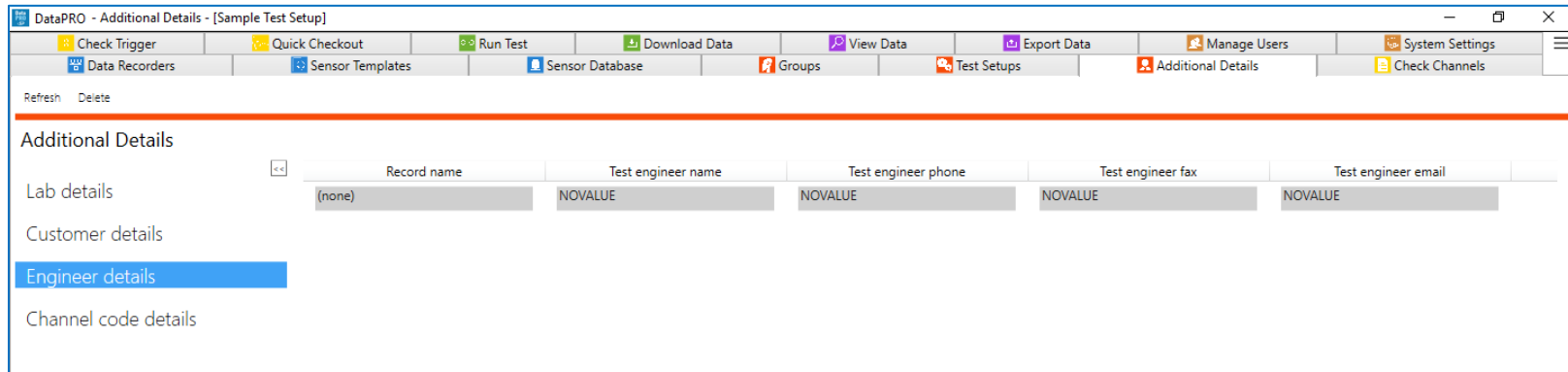

Record name	Test engineer name	Test engineer phone	Test engineer fax	Test engineer email
(none)	NOVALUE	NOVALUE	NOVALUE	NOVALUE

- a. This information can be modified before exporting data.
 - b. Records are automatically saved.
3. To delete an Engineer Details Record, select the record from the list and select Delete.
 4. To return to the Quick Start steps, go back to page 32.

Channel Code Details

A Channel Code is a shorthand code used to describe a measurement channel. Channel Codes can either follow the ISO MME protocol of 16 alpha-numeric characters, or they can be “User Codes” and contain an unrestricted number of characters of any type. See <https://www.iso-mme.org/> for more information on ISO Codes.

1. Select the “Additional Details” tab.
2. Select “ISO 13499” or “User” to display the current available channel codes:

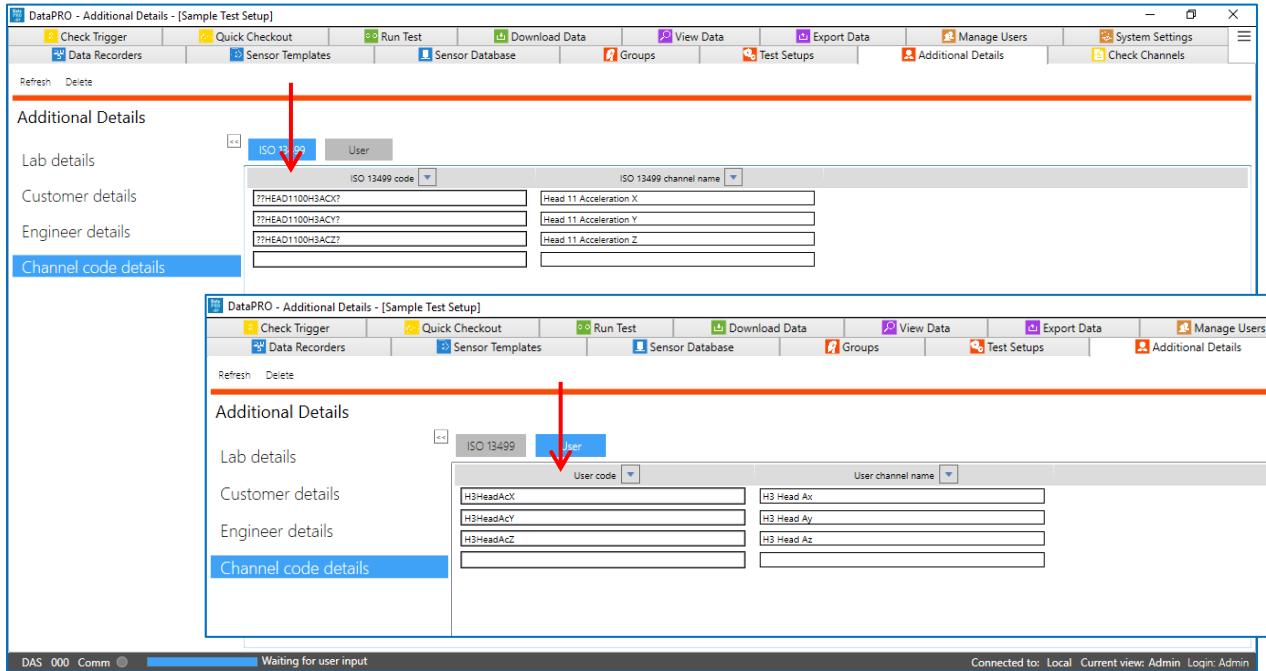

- a. Any ISO Codes used that are not defined by ISO/TS 13499 will be listed in and managed through the Channel codes details table in the Additional Details tab.
 - b. All User Codes will be listed in and managed through the Channel codes details table in the Additional Details tab.
3. Create new Channel Codes by typing in the last field.
 - a. Multiple codes can be created by pasting multiple Channel Codes/Channel Names into the last field.
 4. To edit a Channel Code or Channel Name, select the field to edit and enter the corrected information.
 5. To delete a Channel Code from the database, select the Channel Code from the list, select “Delete.”
 - a. Select and delete multiple Channel Codes using Shift or Ctrl during code selection.
 6. To return to the Quick Start steps, go back to page 32.

Diagnostics

Diagnostic functions (channel, sensor, hardware and trigger checks) are performed as a part of a data collection sequence. The Diagnostic tabs allow for these functions to be performed separately, outside of a data collection routine, to verify proper functioning of the system.

DataPRO automatically generates a series of reports during use of the Diagnostic and Record tabs. See

Check Channels

Check Channels confirms the hardware connection and sensor assignment, then performs a diagnostic/channel checkout routine and allows verification of channel output(s) in Realtime Mode.

1. Select the “Check Channels” tab:



- a. Optionally, select Check Channels from within a completed, saved Test Setup:

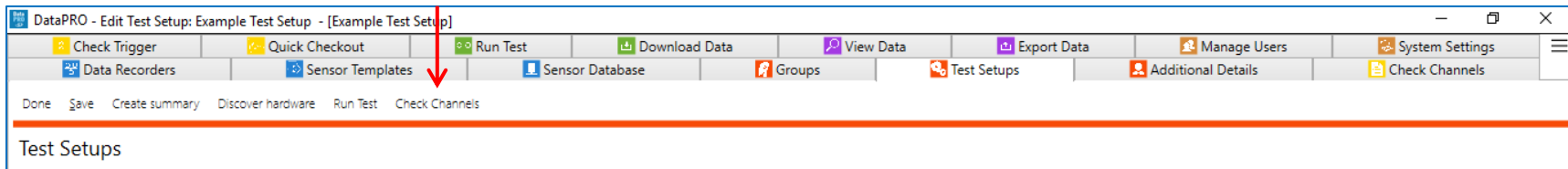

- The **Hardware** navstep will automatically attempt to connect to the hardware associated with the active test setup, as well as any attached USB device:

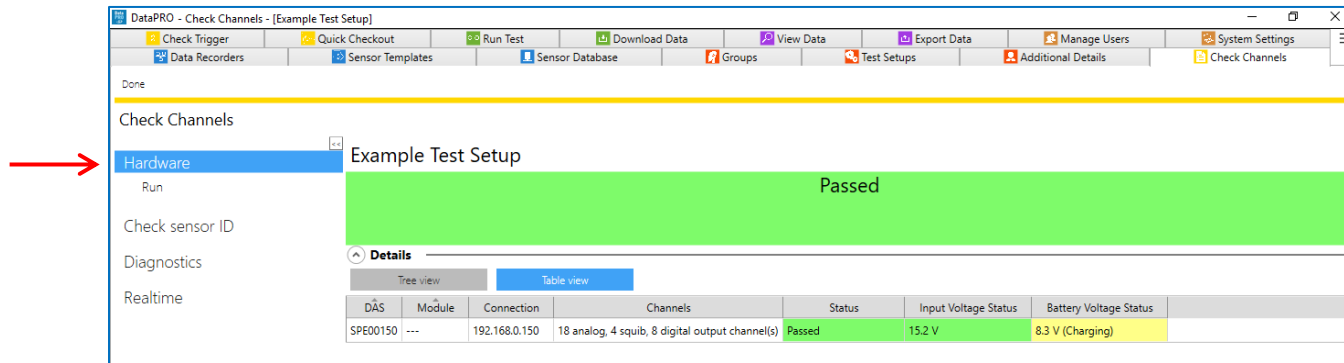

- Select Run to re-run the Hardware navstep.

- Select the **Check sensor ID** navstep to perform a sensor check:

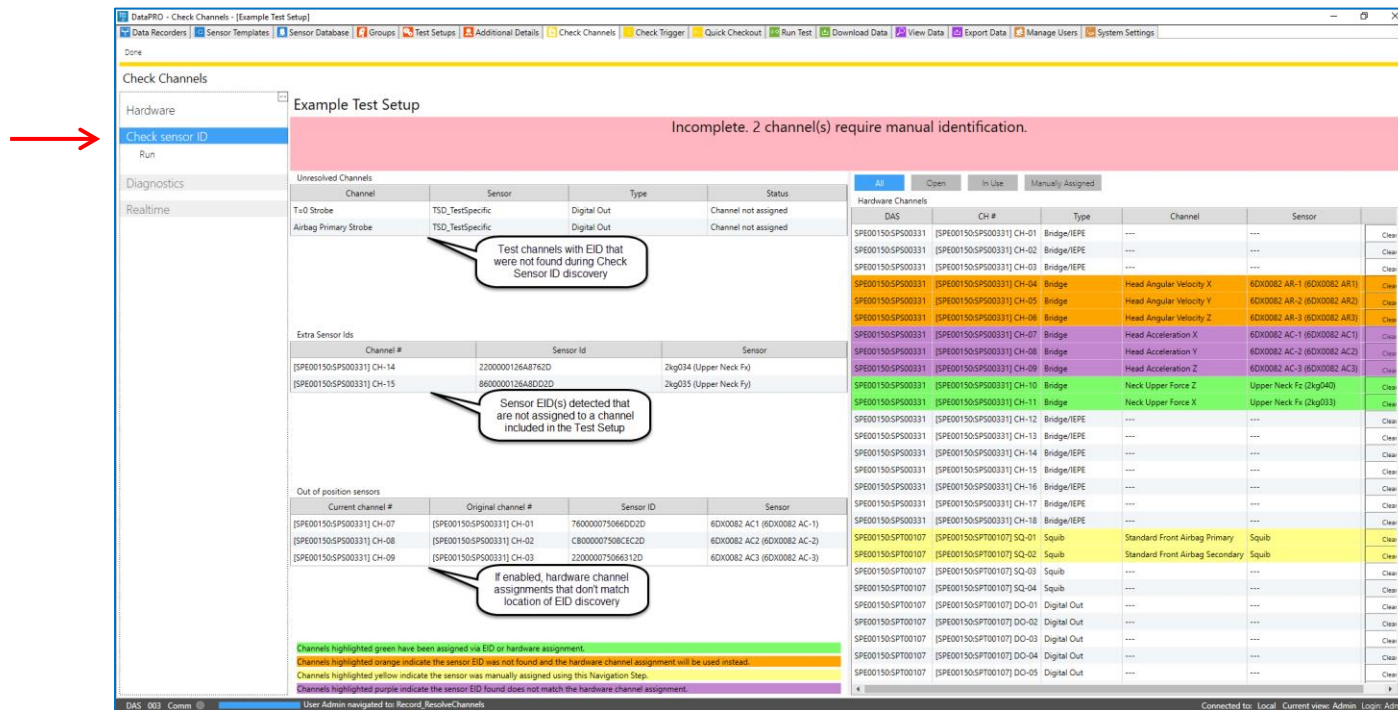

- a. The Check Sensor ID step verifies each channel in the Test Setup has been configured with a hardware channel.
 - i. Sensors with EID will automatically populate with the hardware channel assignment.
 - ii. Sensors without EID will need to be 'resolved' and manually assigned to a hardware channel.

NOTE: Manual assignments of hardware channels performed in Check Channels or in Run Test will have to be repeated for subsequent Check Sensor ID initiations.

- b. DataPRO indicates the following EID conditions with different tables:
 - i. Unresolved Channels: Channels that have not been configured with a hardware channel assignment. These channels need to be manually assigned.
 - ii. Extra Sensor IDs: Sensor EID(s) detected that are not assigned to a channel included in the Test Setup.
 - iii. Out of position sensors (if enabled): Sensor EID(s) that are detected on a hardware channel that differs from the Test Setup configuration.
- c. DataPRO indicates the following channel configuration conditions with highlighting:
 - i. Green: EID or manual hardware assignment completed in Group or Test Setup.
 - ii. Orange: EID not found, hardware assignment completed in Group or Test Setup.
 - iii. Yellow: Manual hardware assignment completed in current step.
 - iv. Purple: EID found does not match hardware assignment completed in Group or Test Setup (Channel is Out of Position).

NOTE: Channel Out Of Position indication is optional and must be enabled in System Settings, page 210.

4. Select the **Diagnostics** navstep and then select “Run” to perform a diagnostic check on all channels, “Run (DAS)” to perform a diagnostic check on one DAS module or “Run (Channel)” to perform a diagnostic check on one channel:

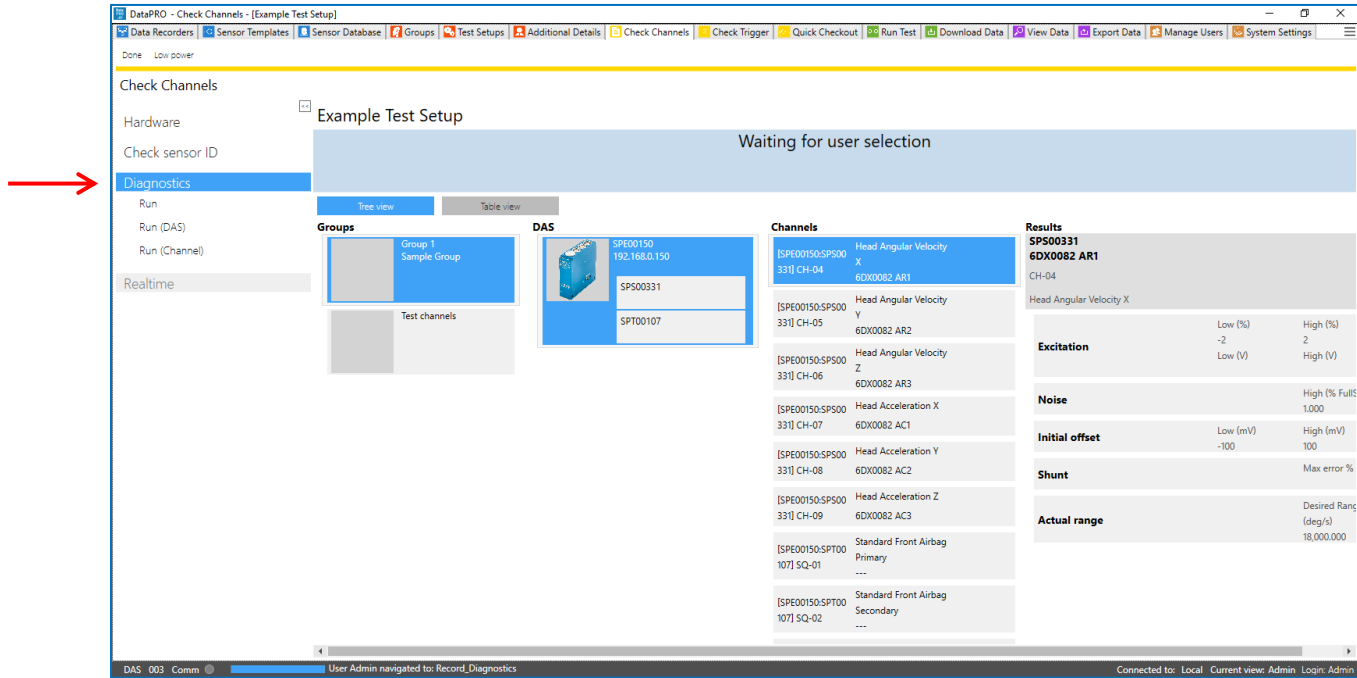

- a. Tree View (above) is the default display, select Table View (below) to display diagnostic data in table format:

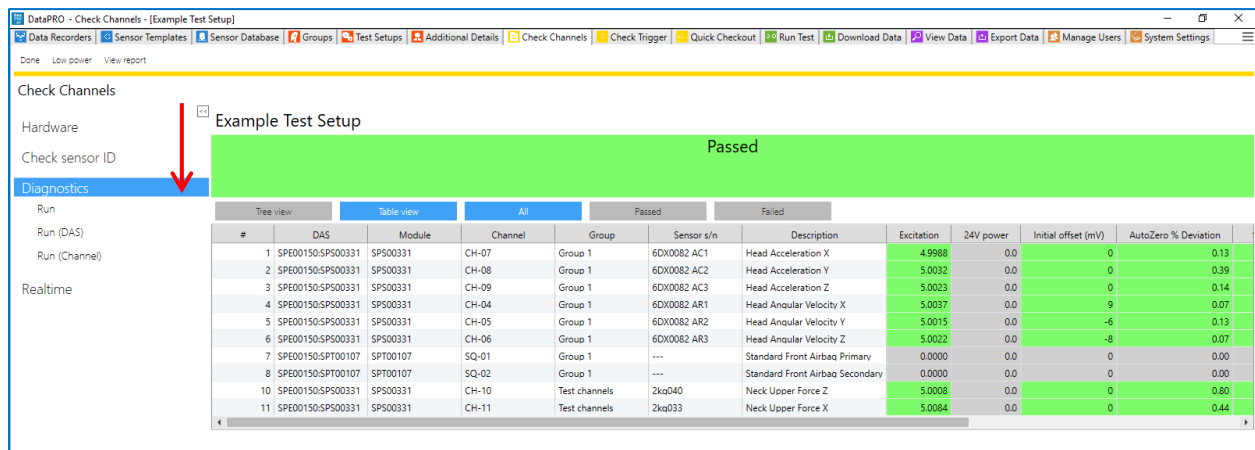

b. Select individual channels in Tree View to display diagnostic results for that channel:

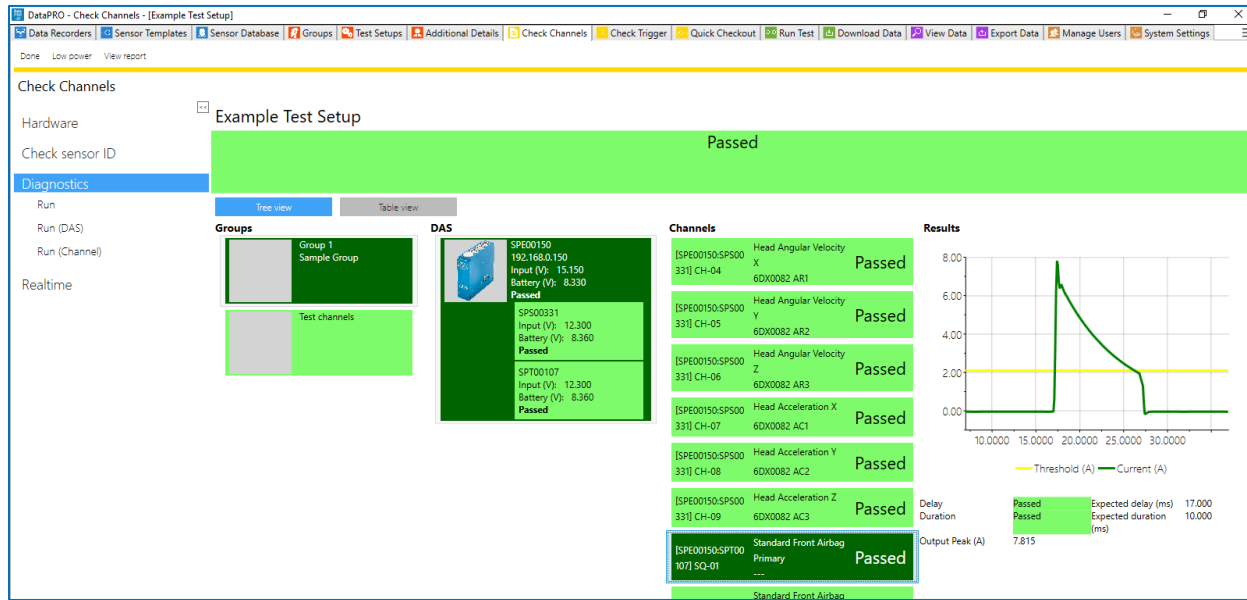

i. Test Setups can be configured to require all channels to pass Diagnostics before progressing to Realtime.

5. Select the **Realtime** navstep to verify sensor output.

Realtime - Level Triggers Off



NOTE: If *UseTestChannelOrder* is enabled in the *DataPRO.exe.config* file, only one chart will be available and one channel will be displayed at a time in Realtime.

NOTE: Realtime AAF ratio is 1:1 by default. This setting can be changed in the *DataPRO.exe.config* file. See *DataPRO Settings Manual* for more information about the config file.

- a. The initial display is defined by the test setup.
- b. Realtime display selection. See [Test History Settings](#), page 230, for more information on configuring the initial Realtime display.



1. Select Prev/Next to backtrack/advance 1/3/6 channel(s) based on chart(s) displayed.
2. Use snap arrows to hide or display the navstep menu.
3. Select Settings to display additional Realtime settings and options.

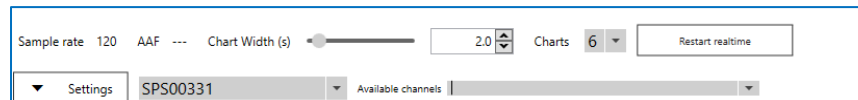

- a. Current Sample Rate and AAF value displayed.
 - b. Modify chart width.
 - c. Select 1, 3, or 6 charts.
 - d. Restart Realtime to apply changes.
 4. Select DAS from drop-down to choose channels to display.
 - a. Channels can only be displayed from one DAS at a time.
 5. Use Available Channels drop-down to select from all channels in Test Setup.
 - a. Type Serial Number, Sensor Description, Channel Name or ISO Code to search.
 6. Use chart drop-down to select channel(s) from current DAS.
- c. Display units:

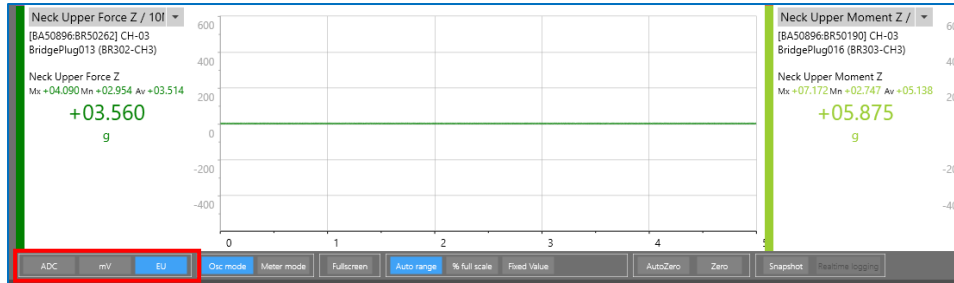

i. Select ADC, mV, or EU.

d. Oscilloscope/Meter Mode:

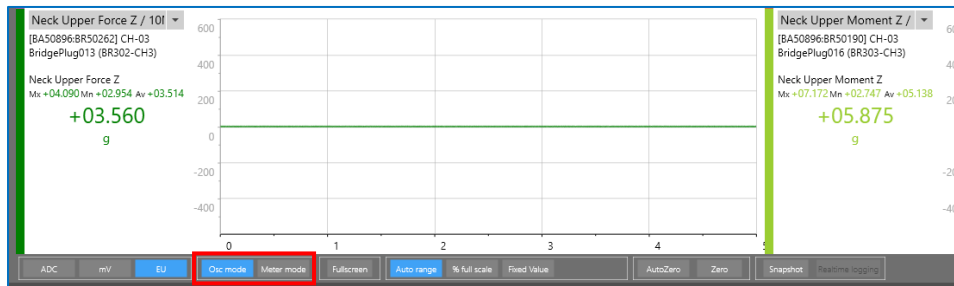

i. Osc mode (Oscilloscope) displays 1, 3 or 6 charts of analog output.

ii. Meter Mode displays digital readout of all channels in Test Setup.

1. Select subgroups of channels to display based on Tags applied in Sensor Database.

e. Select “Fullscreen” to enlarge active chart to fullscreen:

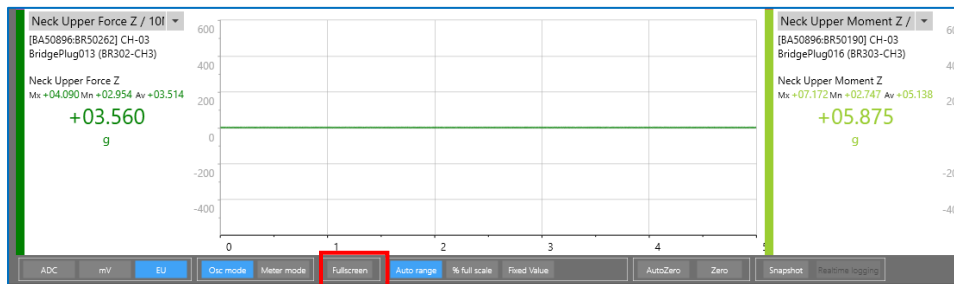

f. Display range:

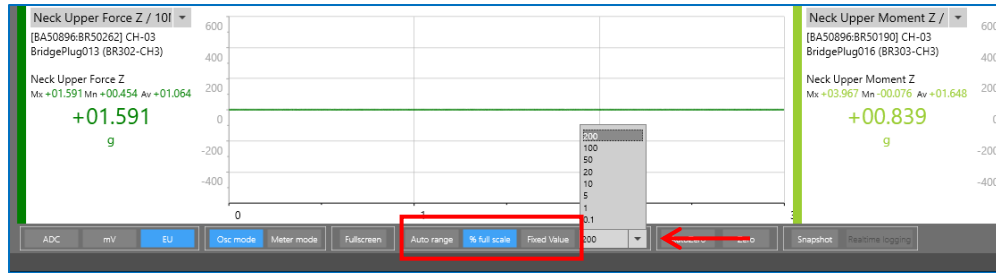

- i. Select “Auto range” to display a predefined percentage of the full scale range.
 - 1. Default Auto range value is 6.6% of full scale and can be modified in *DataPRO.exe.config* file.
- ii. Select “% full scale” to select the percentage of full scale to display.
- iii. Select “Fixed value” to select a fixed value to display.

g. AutoZero/Zero:

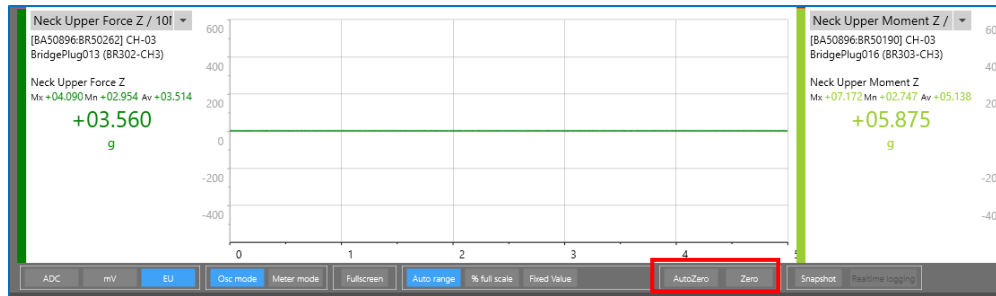

- i. Select “AutoZero” to automatically software zero channels when selecting a new channel to display.
- ii. Select “Zero” to software zero all channels.

h. Snapshot/Realtime logging:

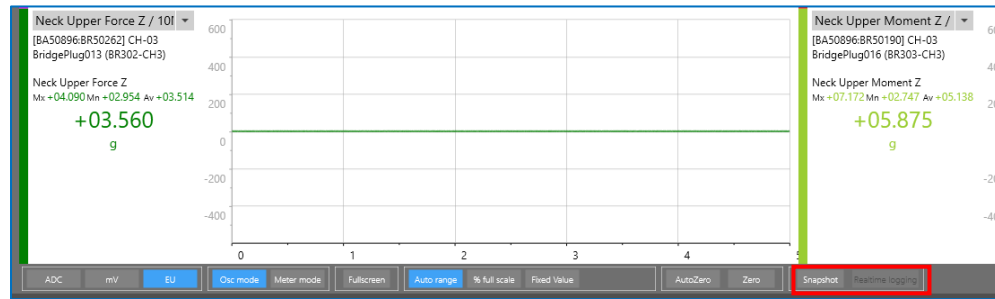

- i. Select “Snapshot” to output an excel file for each displayed channel with the ADC, mV and EU data for that sample. Snapshot files will be saved in the Data folder (see

- ii. Appendix E: DataPRO File Structure, page 275, for more information) unless the option to save snapshots to clipboard is enabled in System Settings.
- iii. Select “Realtime logging” to enable Realtime logging for all channels displayed on the chart. Realtime logging files will be saved in the Data folder.



NOTE: Realtime logging is only available when 1 Chart is displayed.

Realtime - Level Triggers On

DataPRO includes an optional “Level Trigger” check in Realtime. The level trigger threshold is set as a percentage of the sensor’s full scale output and can be modified in Realtime. This can be used to verify polarity or channel output.

To configure DataPRO to have “Level triggers on” in Realtime:

- Enable UseTestChannelOrder in the DataPRO.exe.config file.
- Enable Level triggers on in System Settings tab -> Realtime navstep.

If DataPRO is configured to have “Level triggers on” in Realtime, the Realtime display will allow only one channel to be displayed on a single chart.



- Level Trigger threshold is indicated by the dashed line and can be moved to allow for easier sensor output verification.
- Optional audible beeping indicates waiting for trigger and trigger received. (See [Realtime Settings](#), page 231.)
- If enabled, displayed channel will advance once level trigger has been received.
- DataPRO will automatically save *.png and *.CSV files of the data and plot to the Realtime folder of the dataset. See

- e. [Appendix E: DataPRO File Structure](#), page 275, for more information.
6. Select “Done” to return the previous location. To return to the [Quick Start](#) steps, go back to page 32.

Check Trigger

Check Trigger confirms the hardware connection and sensor assignment, as well as allows for verification of the Event signal (See [System Settings](#), page 210, to configure the system to test the Start Record signal as well). The Arm Checklist provides a squib resistance measurement if squibs are included in the Test Setup.

1. Select the “Check Trigger” tab:



2. The **Hardware** navstep will automatically attempt to connect to the hardware associated with the active test setup.
 - a. Select Run to re-test the hardware connection.
3. Select the **Check sensor ID** navstep to perform a sensor check.
 - a. Select run to re-scan for sensor IDs.
4. Select the **Check trigger** navstep, select “Run”, then generate a hardware trigger signal. Select “Cancel trigger check” to bypass the trigger check, or “Software trigger” to send a trigger signal command and progress to Arm Checklist:

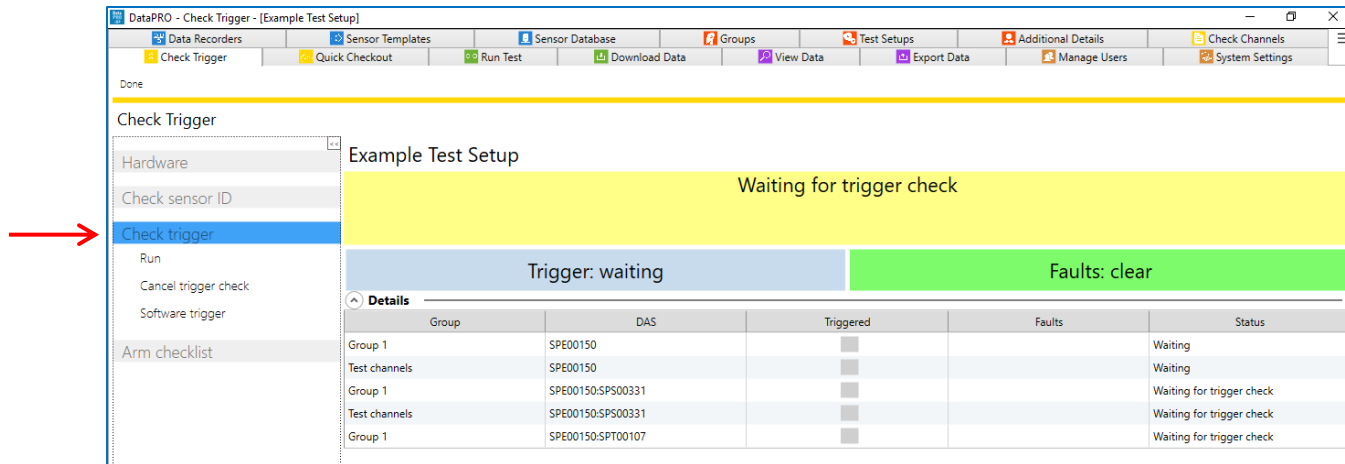

... Trigger signal is sent ...

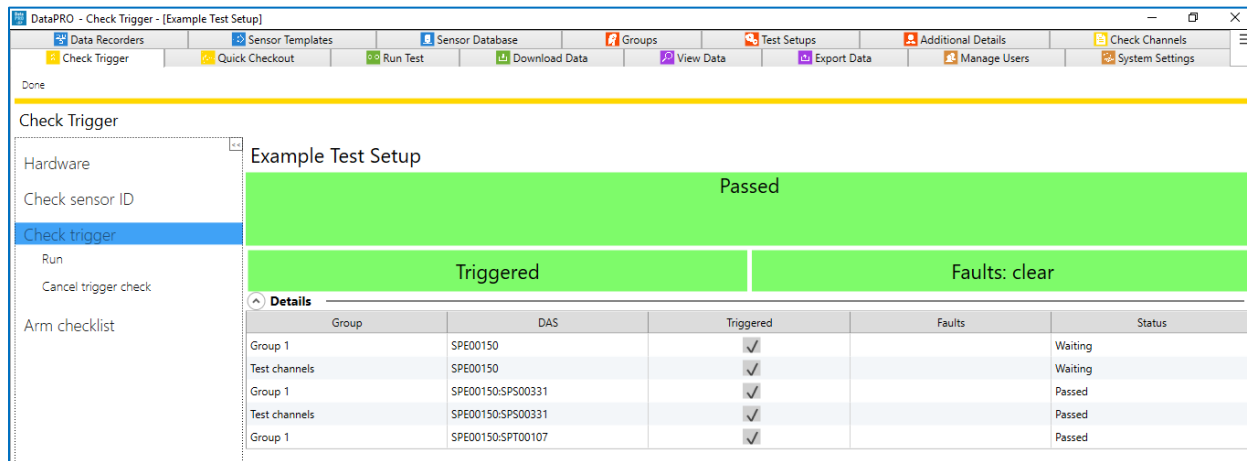

5. Select Arm Checklist, select "Run" to perform tests defined in Test Setup:

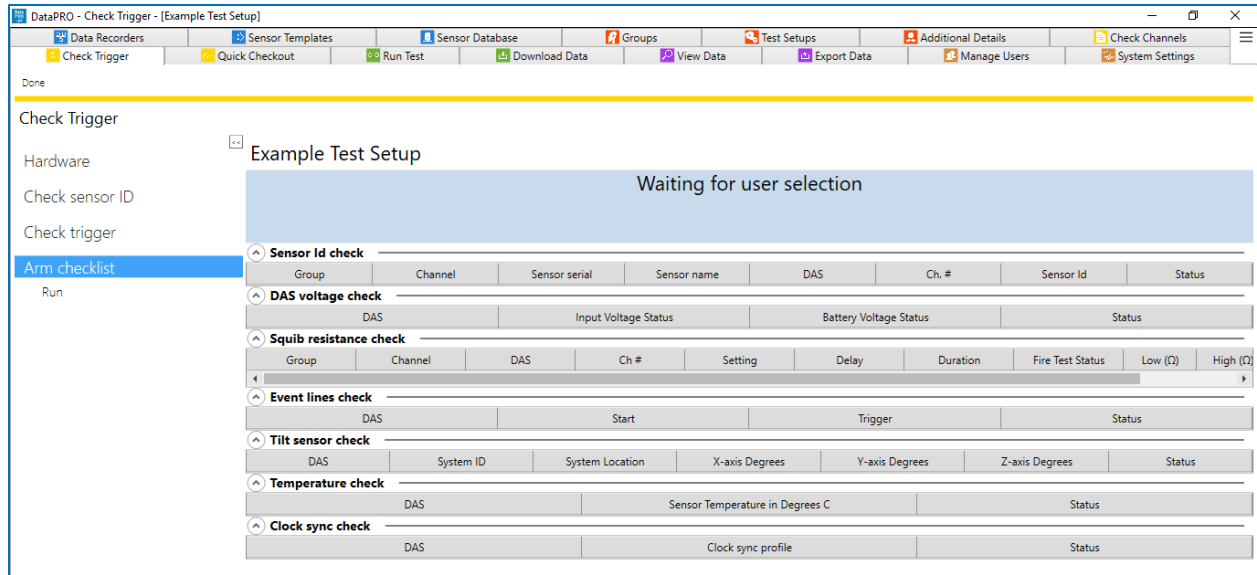

a. Sensor ID check:

Sensor ID check							
Group	Channel	Sensor serial	Sensor name	DAS	Ch. #	Sensor Id	Status
Group 1	Head Acceleration X	6DX0082 AC1	6DX0082 AC-1	SPE00150:SPS00331	CH-07	760000075066DD2D	Passed
Group 1	Head Acceleration Y	6DX0082 AC2	6DX0082 AC-2	SPE00150:SPS00331	CH-08	C8000007508CEC2D	Passed
Group 1	Head Acceleration Z	6DX0082 AC3	6DX0082 AC-3	SPE00150:SPS00331	CH-09	220000075066312D	Passed
Group 1	Head Angular Velocity X	6DX0082 AR1	6DX0082 AR-1	SPE00150:SPS00331	CH-04	EC0000173C278B01	Passed
Group 1	Head Angular Velocity Y	6DX0082 AR2	6DX0082 AR-2	SPE00150:SPS00331	CH-05	380000173C27C301	Passed
Group 1	Head Angular Velocity Z	6DX0082 AR3	6DX0082 AR-3	SPE00150:SPS00331	CH-06	250000173C116001	Passed

i. Performs a scan and compares Sensor IDs found to assignments defined in Test Setup.

b. DAS voltage check:

DAS voltage check				
DAS	Input Voltage Status	Battery Voltage Status	Status	
SPE00150:SPS00331	12.3 V	8.4 V (Charging)	Passed	
SPE00150:SPT00107	12.3 V	8.3 V (Charging)	Passed	
SPE00150	15.1 V	8.3 V (Charging)	Passed	

i. Measures input voltage and battery voltage of connected DAS and compares to power threshold settings defined in System Settings (See System Settings, page 210).

c. Squib resistance check:

Group	Channel	DAS	Ch #	Delay	Dur...	Fire Test Status	Low (Ω)	High (Ω)	Resistance (Ω)	Status	Setting
Group 1	Standard Front Airbag Primary	SPE00150:SPT00107	SQ-01	17.00	10.00	N/A	0.9	8.0	3.66	Passed	---
Group 1	Standard Front Airbag Secondary	SPE00150:SPT00107	SQ-02	20.00	10.00	N/A	0.9	8.0	3.66	Passed	---

- i. Measures resistance of squib channels and compares measurement to threshold values defined in Test Setup Parameters.

NOTE: *Delay, Duration and Fire Test Status are only tested/reported if using “Slow Trigger Check” method (See System Settings, page 210). If not using “Slow Trigger Check” method, requested values from Test Setup will be displayed.*

d. Event lines check:

DAS	Start	Trigger	Status
SPE00150:SP500331	<input type="checkbox"/>	<input type="checkbox"/>	Passed
SPE00150:SPT00107	<input type="checkbox"/>	<input type="checkbox"/>	Passed
SPE00150	<input type="checkbox"/>	<input type="checkbox"/>	Passed

- i. Checks Start and Event lines and reports current status of connected DAS.

e. Tilt sensor check – SLICE6 only:

DAS	System ID	System Location	X-axis Degrees	Y-axis Degrees	Z-axis Degrees	Status
SL60014	010	Example 1	NaN	-0.8	-87.4	N/A
SL60023	020	Example 3	0.3	NaN	-87.3	N/A

- i. Reports current tilt measurements from SLICE6 DAS.

NOTE: *Tilt sensors are configured using the Tilt Sensor Control utility.*

f. Temperature check – SLICE6DB only

- i. Reports current temperature reading of connected SLICE6 Distributor.

g. Clock sync check

6. Select “Done” to return to the previous location. To return to the [Quick Start](#) steps, go back to page 32.

NOTE: *For distributors and devices which do a single one shot pulse for trigger, the OneShotWaitTimeMs setting in the DataPRO.exe.config file controls the amount of time to wait (in ms) for a trigger signal to clear. It is not expected that this value will need to be changed, but in cases where a distributor shows as already triggered during trigger checks this time can be increased. Refer to the DataPRO Settings Manual for more information about the config file.*

Quick Checkout

Quick Checkout allows for quickly creating a single-use test setup based on connected channels. This test setup will not be saved but will allow a diagnostic checkout and Realtime verification of connected or manually assigned channels.

1. Select the “Quick Checkout” tab:

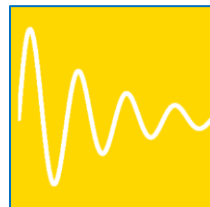

NOTE: *There is an optional setting in DataPRO.exe.config to automatically Query Hardware when using Quick Checkout. If this setting is set to true, start at Step 3.*

2. Select DAS to be used during Quick Checkout.
 - a. If using EID, select “Query selected” to query hardware for attached sensors and ids:

Check Trigger Quick Checkout Run Test Download Data View Data Export Data Manage Users System Settings

Query selected Run check

Quick Checkout

Waiting

Data Recorders

Included	Serial number	Type	Channels	Firmware	Max sample rate	Cal date	First Use Date	Cal due date	Sample rate
<input type="checkbox"/>	BA51253	SLICE NANO Base+	15 analog channel(s)	B1F4	200,000	4/29/2019	---	4/28/2020	---
<input type="checkbox"/>	SPD00999	SLICE PRO DIM	18 digital input channel(s)	A1J4	600,000	4/7/2016	---	4/7/2017	---
<input checked="" type="checkbox"/>	SPE00150	SLICE PRO Ethernet Controller	SLICE PRO Ethernet Controller	B0B3	---	---	---	---	---
<input type="checkbox"/>	SPS00999	SLICE PRO SIM	18 analog channel(s)	A1J4	600,000	4/7/2016	---	4/7/2017	---
<input type="checkbox"/>	SPT00999	SLICE PRO TOM	4 squib, 8 digital output channel(s)	D0D7	600,000	4/7/2016	---	4/7/2017	---

Extra Sensor Ids

Channel	Dallas ID

Manual assignments

Channel List

Search Show bottom row

0 channel(s) in test 0 of 0 physical channel(s) assigned

TOP ▲ BOT Remove Sensor Delete

Group	ISO (13499) code	ISO channel name	Type	Sensor (SN)	Dallas ID	Hardware

TOP ▲ -001 BOT Remove Sensor Delete

- b. If not using EID or to assign additional, undiscovered channels for checkout, select “Manual assignments” to enable manually assigning sensors to hardware channels:

Check Trigger Quick Checkout Run Test Download Data View Data Export Data Manage Users System Settings

Query selected Run check

Quick Checkout

Waiting

Data Recorders

Included	Serial number	Type	Channels	Firmware	Max sample rate	Cal date	First Use Date	Cal due date	Sample rate
<input type="checkbox"/>	BA51253	SLICE NANO Base+	15 analog channel(s)	B1F4	200,000	4/29/2019	---	4/28/2020	
<input type="checkbox"/>	SPD00999	SLICE PRO DIM	18 digital input channel(s)	A1J4	600,000	4/7/2016	---	4/7/2017	
<input checked="" type="checkbox"/>	SPE00150	SLICE PRO Ethernet Controller	SLICE PRO Ethernet Controller	B0B3	---	---	---	---	
<input type="checkbox"/>	SPS00999	SLICE PRO SIM	18 analog channel(s)	A1J4	600,000	4/7/2016	---	4/7/2017	
<input type="checkbox"/>	SPT00999	SLICE PRO TOM	4 squib, 8 digital output channel(s)	D0D7	600,000	4/7/2016	---	4/7/2017	

Extra Sensor Ids

Channel	Dallas ID

Manual assignments 

Channel List

Search Show bottom row

0 channel(s) in test 0 of 0 physical channel(s) assigned

TOP BOT Remove Sensor Delete

Group	ISO (13499) code	ISO channel name	Type

Drag and drop sensors or hardware here to create new channels
Drag a squib or digital output hardware channel to create a squib or digital output setting

Highlighted cells will use ID for assignment

Sensors Available

Search Assigned Unassigned All

Online

Serial Number	Name	IEPE	Capacity (EU)	Units	Out Of Date	In Warning Period
2kg033	Upper Neck Fx		2,000.00	g		

Hardware

Search

DAS	CH #	Type	Channel	Sensor	
SPE00150:SPS00331	[SPE00150:SPS00331] CH-01	Bridge/IEPE	---	---	Clear
SPE00150:SPS00331	[SPE00150:SPS00331] CH-02	Bridge/IEPE	---	---	Clear
SPE00150:SPS00331	[SPE00150:SPS00331] CH-03	Bridge/IEPE	---	---	Clear

- i. Quick Checkout channel assignments are the same as those for Groups and Test Setups (See [Groups](#), page 66, for more information).
- ii. The Extra Sensor Ids table shows EIDs which were detected but not associated with any sensors in the sensor database.

3. Select “Run Check” after all channel assignments have been made:

The screenshot shows a software interface with a top navigation bar containing buttons for 'Check Trigger', 'Quick Checkout', 'Run Test', 'Download Data', 'View Data', 'Export Data', 'Manage Users', and 'System Settings'. Below the navigation bar, a 'Query selected' dropdown is set to 'Run check'. A large green banner with the word 'Done' is visible. The main content area is divided into several sections:

- Data Recorders:** A table with columns: Included, Serial number, Type, Channels, Firmware, Max sample rate, Cal date, First Use Date, Cal due date, Sample rate. One row is shown with 'SPE00150' and 'SLICE PRO Ethernet Controller'.
- Extra Sensor Ids:** A table with columns: Channel, Dallas ID. Two rows are shown for channels CH-01 and CH-03.
- Channel List:** A section with a search bar and a table of channels. The table has columns: Group, ISO (13499) code, ISO channel name, Type. It lists six test channels with various ISO codes and names like '6DX0082 AR1'.
- Sensors Available:** A section with a search bar and a table of sensors. The table has columns: Serial Number, Name, IEPE, Capacity (EU), Units, Out Of Date, In Warning Period. One sensor is shown: '2kg033 Upper Neck Fx' with a capacity of '2,000.00 g'.

4. This will begin the Check Channel process (See [Check Channels](#), page 128, for more information).

Record

Run Test

Use the Run Test tab to initiate a data collection sequence based on the active Test Setup. The settings and parameters in the Test Setup and the System Settings tabs determine the navsteps and behavior of DataPRO during the data collection process (See [Test Setups](#), page 83, or [System Settings](#), page 210, for more information).

The steps and images below are for a “Record In Place” test, where data is stored on the internal flash memory of the DAS. For information on configuring SLICE6 AIR DAS for a Streaming test, see [Appendix I: SLICE6 AIR Setup](#), page 327.

DTS recommends using the Diagnostic tab(s) prior to collecting data. However, many of the same steps will be repeated with each Data Collection sequence.

Navsteps are configurable for each Test Setup. Not all navsteps listed are required, therefore some steps listed below may not be applicable.

1. Select the “Run Test” tab:



2. The **Basic info** navstep displays an overview of the test setup:

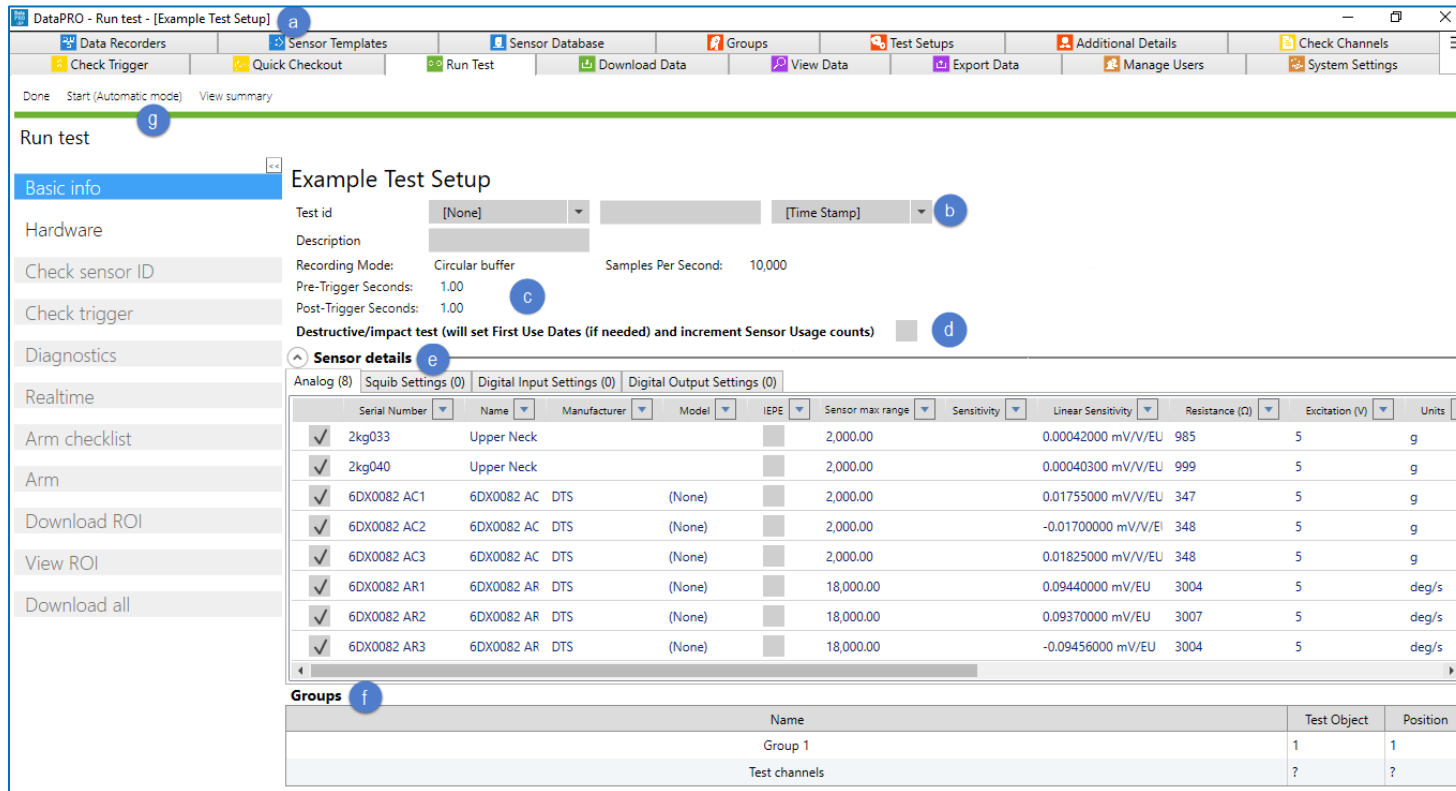

- a. Test Setup and Test ID are displayed throughout data collection sequence.
- b. Test ID prefix and suffix can be selected from pre-defined options. Set pre-defined options in System Settings tab (See [System Settings](#), page 210, for more information).
- c. Verify recording mode/parameters as defined in Test Setup.
- d. If the Destructive/Impact Test box is checked, running the test will set the First Use Date for DAS or sensors that have not been used since the last calibration, and will increment the usage count of all sensors in the Test Setup. Note: This feature is only supported for SLICE hardware and must be enabled on the hardware by DTS personnel.
- e. Verify sensors in test in Sensor details table.

NOTE: *DataPRO can be configured to allow or to prevent running a test with sensors and hardware that is past due for calibration (See [System Settings](#), page 210, for more information).*

- f. Verify Groups in test. Select up/down arrows to hide/display sensor list.
- g. Select Start to start Automatic test progression, if enabled. Select View Summary to review Test Summary (Test Summary will be automatically generated and saved with data files. See

h. [Appendix E: DataPRO File Structure](#), page 275, for more information).

3. Continue to the **Hardware** navstep. DataPRO will attempt to communicate with the hardware associated with the active Test Setup:

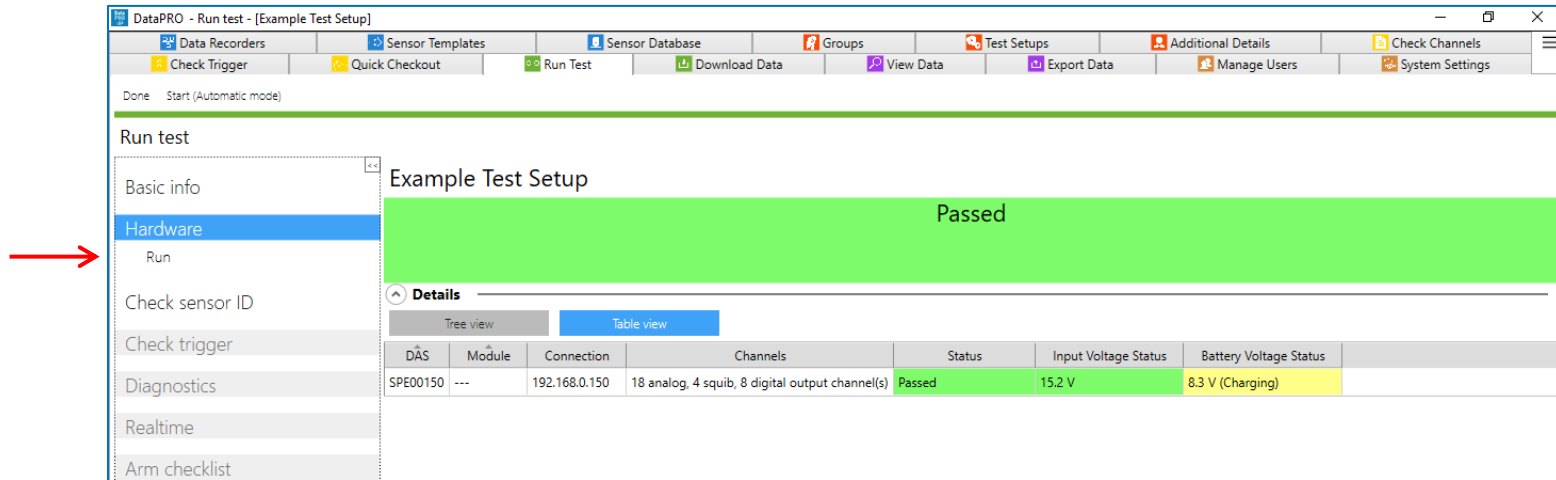

a. If needed, select Run to re-run Hardware navstep and reattempt hardware connection.

4. Proceed to **Check sensor ID** navstep to confirm sensors in test setup are properly configured with a hardware channel. Sensors without EID that have not yet been configured with hardware channels will need to be manually assigned before proceeding:

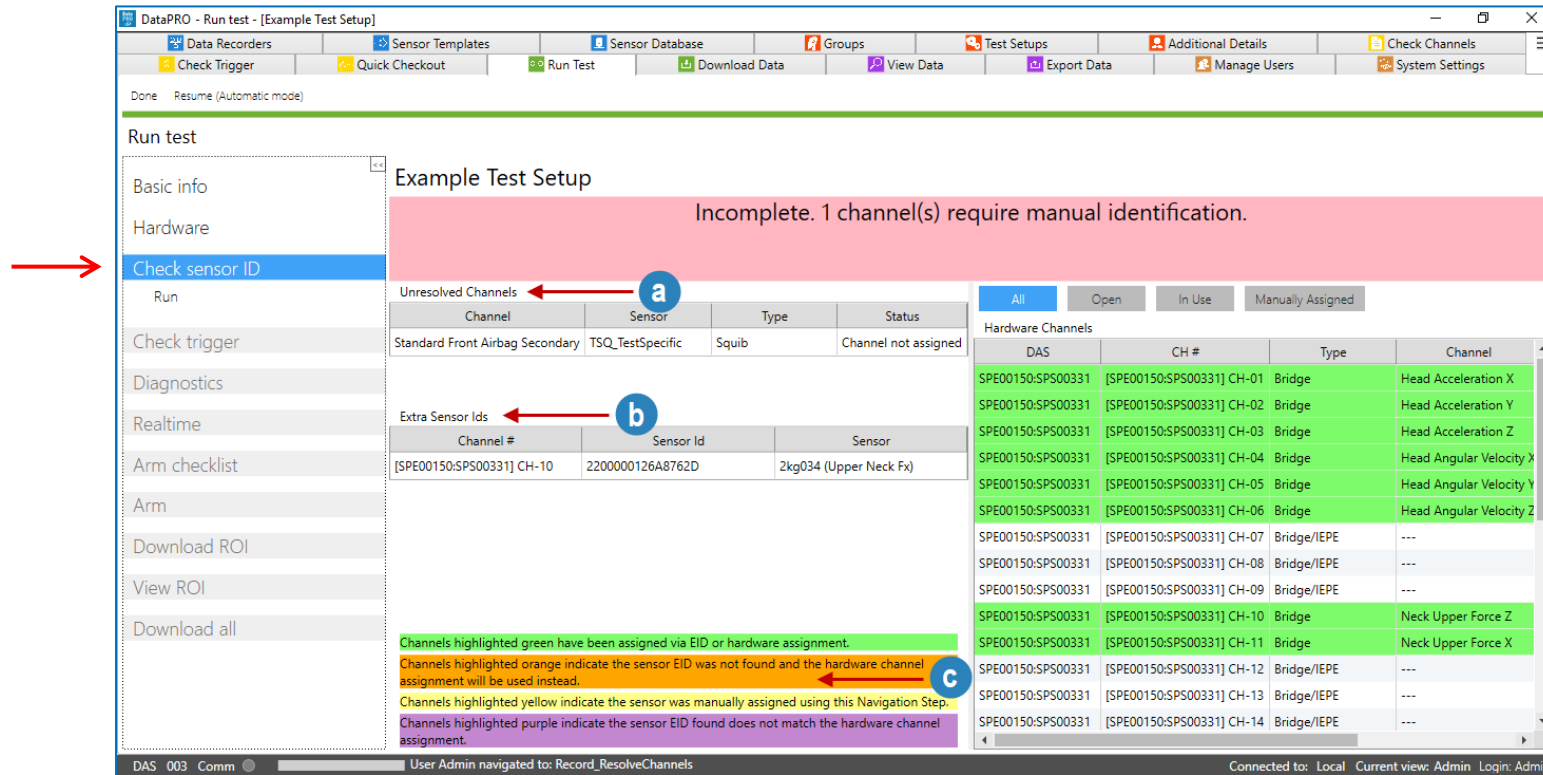

- a. Channels that are included in the Test Setup but not yet assigned to hardware channels will be listed in the Unresolved Channels table.
 - i. Select from Unresolved Channels table and drag to Hardware Channels table to make assignments.
 - ii. Each Test Setup can be configured to allow progressing with missing sensors (unresolved channels) (See [Test Setups](#), page 83, for more information).
- b. Sensor IDs that were detected but are not included in the Test Setup will be displayed in the Extra Sensor IDs table. If the sensor ID(s) are associated with sensors in the Sensor Database, the serial number(s) will be displayed.
- c. The key defines what different shading in the Hardware Channels table indicates (See [Check Channels](#), page 128, for more information).

5. The **Check Trigger** navstep allows the Event signal to be verified. The Check Trigger step is optional and can be configured in multiple ways in the System Settings tab (See [System Settings](#), page 210, for more information):

NOTE: DataPRO can be configured with the Check Trigger navstep to occur after Diagnostics. See [System Settings](#), page 210, for more information.

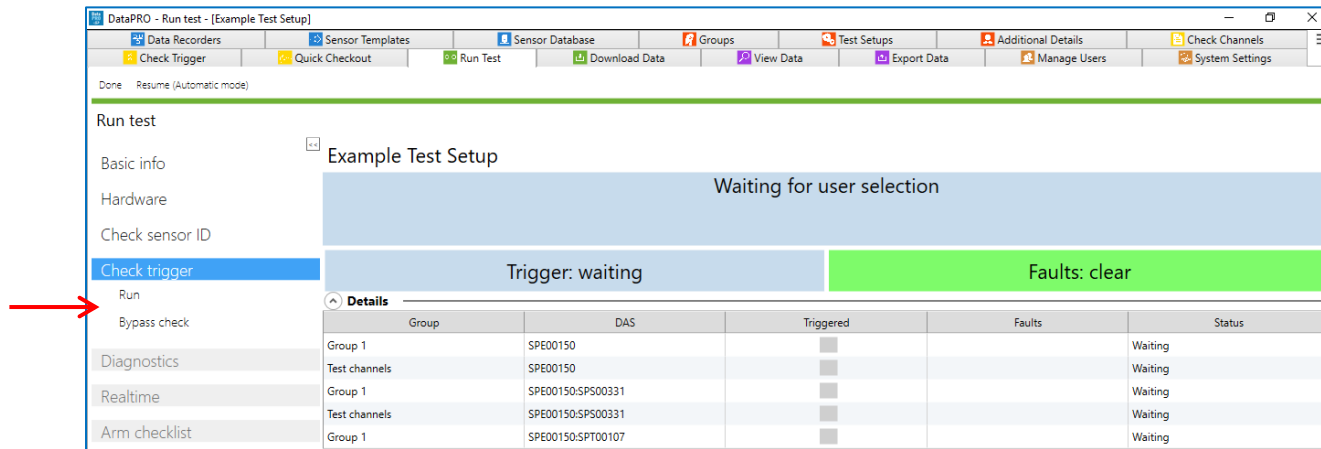

a. Select Run to perform a Trigger Check or Bypass check (if enabled) to bypass the trigger check :

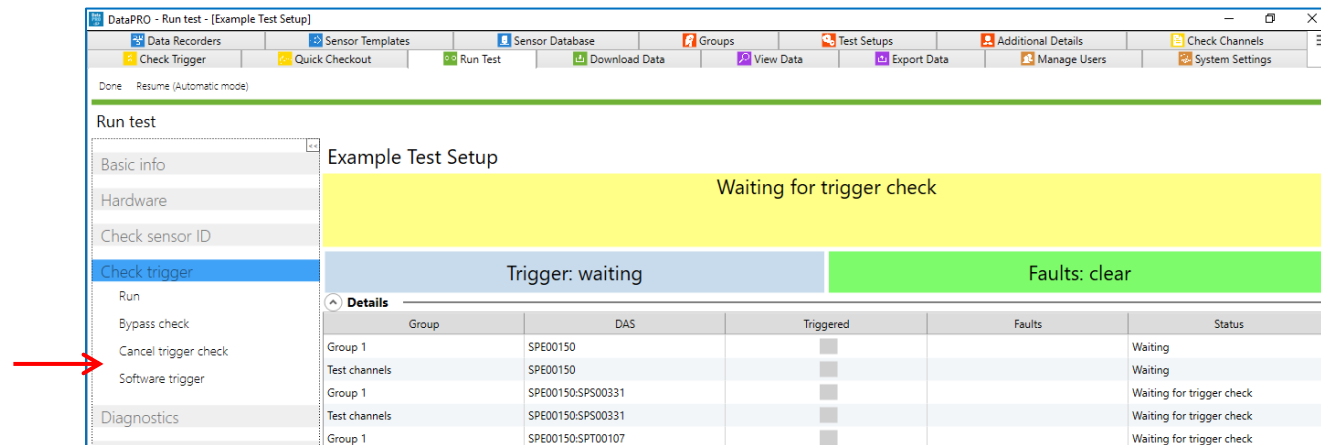

i. After Trigger Check has been run, options to Cancel Trigger Check and issue Software Trigger are available.

b. DAS indicates individual status:

The screenshot shows the DataPRO software interface for a 'Run test' session. The main display area is titled 'Example Test Setup' and shows a large green bar with the word 'Passed' in the center. Below this, a red arrow points to a section labeled 'Triggered' on the left and 'Faults: clear' on the right. A 'Details' table is visible at the bottom, showing individual test results for various groups and channels.

Group	DAS	Triggered	Faults	Status
Group 1	SPE00150	✓		Waiting
Test channels	SPE00150	✓		Waiting
Group 1	SPE00150:SPS00331	✓		Passed
Test channels	SPE00150:SPS00331	✓		Passed
Group 1	SPE00150:SPT00107	✓		Passed

6. Continue to **Diagnostics** navstep. DataPRO will automatically configure the DAS:

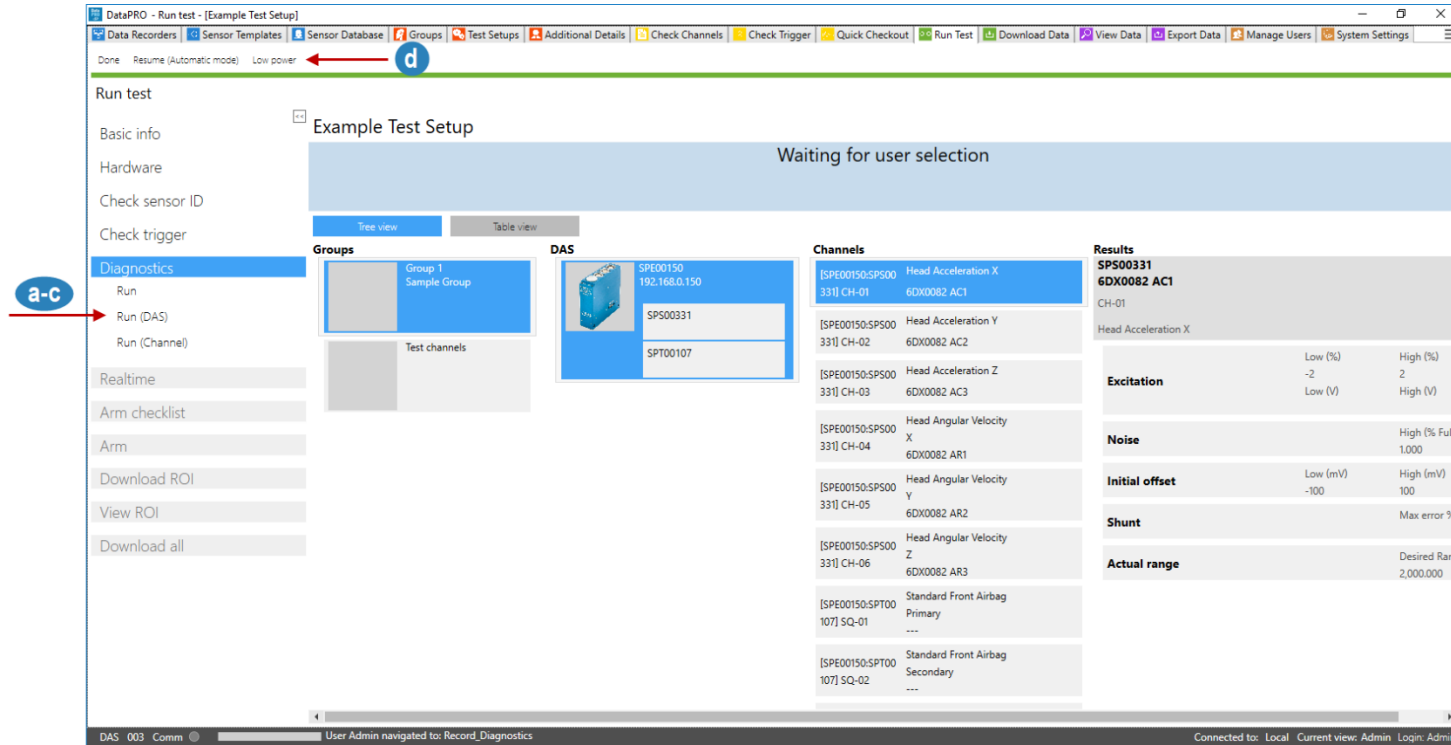

- Select Run to perform a diagnostic checkout on all DAS/Channels included in the Test Setup.
- Select Run (DAS) to perform a diagnostic checkout on only the selected DAS.
- Select Run (Channel) to perform a diagnostic checkout on only the selected Channel.
- Select Low Power to turn off excitation voltage. Diagnostics will have to be performed again to resume data collection sequence.

7. A pre-test diagnostics report will be automatically generated and saved with the test data folder (See

8. [Appendix E: DataPRO File Structure, page 275](#), for more information).
 - a. Select View Report to display this report:

AutoZero % Deviation

Auto deviation is a diagnostic action performed on analog channels when the sensor offset is removed or debiased.

A channel offset is removed by a DAS by adjusting an analog to digital converter to adjust output Analog Data Counts (ADC) to be near zero given the measured sensor offset. After the channel offset is removed the ADC output is measured. The value shown for Auto zero deviation percent is that offset in ADC divided by the maximum ADC that can be recorded.

The purpose of this check is to give an indication of how effective the Auto zero or offset removal was as a percentage. This test will ordinarily fail if the observed offset after auto zero is off by 5%. The deviation percentage allowed can be changed by modifying the setting "AutoZeroPercentDeviationAllowed" in the DataPRO.exe.config file.

9. The **Realtime** navstep allows for Realtime verification of each channel:

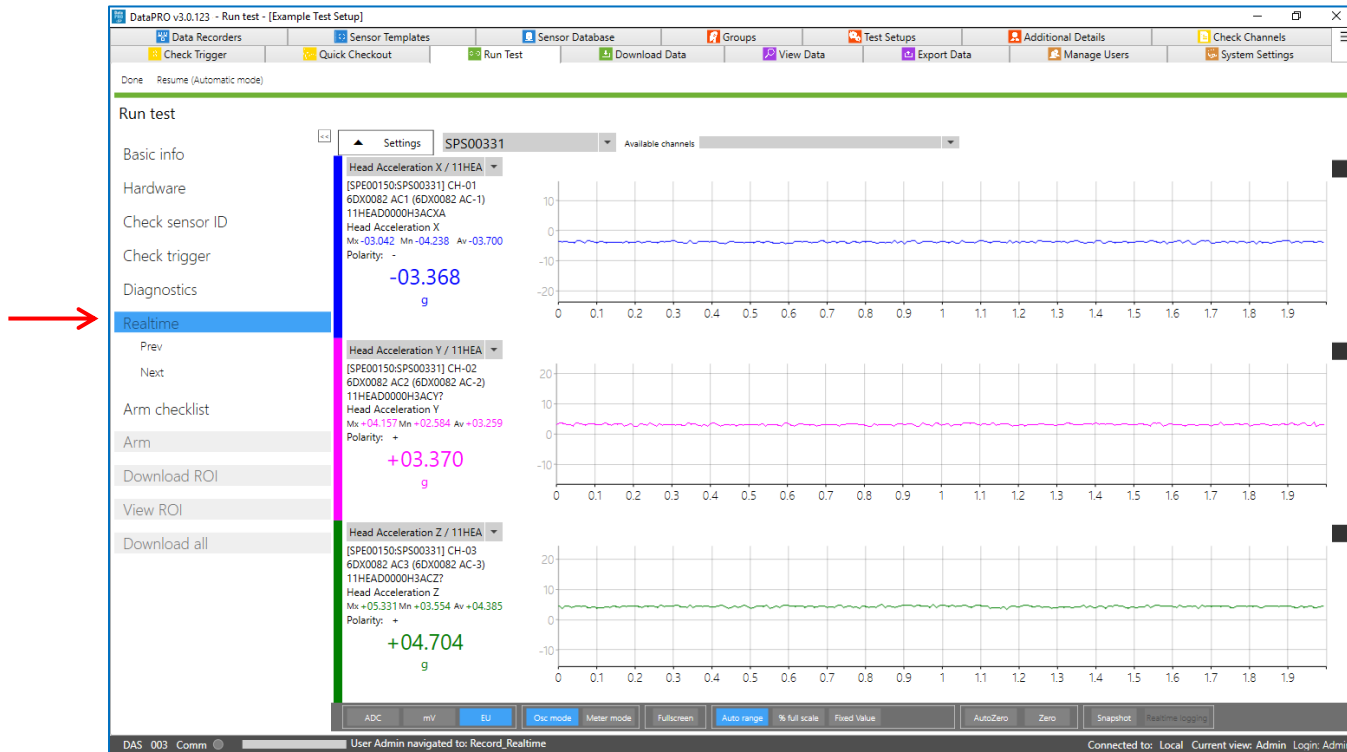

- a. The controls of Realtime in a data collection sequence are the same as the controls for the Check Channels diagnostic tab. (See **Check Channels**, page 128, for more information).

NOTE: Realtime AAF ratio is 1:1 by default. This setting can be changed in the DataPRO.exe.config file. See the DataPRO Settings Manual for more information about the config file.

10. Continue to the **Arm Checklist** navstep (if enabled):

Run test

Basic info **Example Test Setup**

Hardware **Passed**

Check sensor ID

Check trigger

Diagnostics

Realtime

Arm checklist

Run

Arm

Download ROI

View ROI

Download all

Sensor ID check									
Group	Channel	Sensor serial	Sensor name	DAS	Ch. #	Sensor ID	Status		
Group 1	Head Acceleration X	6DX0082 AC1	6DX0082 AC-1	SPE00150:SP500331	CH-01	760000075066DD2D	Passed		
Group 1	Head Acceleration Y	6DX0082 AC2	6DX0082 AC-2	SPE00150:SP500331	CH-02	C8000007508CEC2D	Passed		
Group 1	Head Acceleration Z	6DX0082 AC3	6DX0082 AC-3	SPE00150:SP500331	CH-03	220000075066312D	Passed		
Group 1	Head Angular Velocity X	6DX0082 AR1	6DX0082 AR-1	SPE00150:SP500331	CH-04	EC0000173C278B01	Passed		
Group 1	Head Angular Velocity Y	6DX0082 AR2	6DX0082 AR-2	SPE00150:SP500331	CH-05	380000173C27C301	Passed		
Group 1	Head Angular Velocity Z	6DX0082 AR3	6DX0082 AR-3	SPE00150:SP500331	CH-06	250000173C116001	Passed		

DAS voltage check				
DAS	Input Voltage Status	Battery Voltage Status	Status	
SPE00150:SP500331	12.3 V	8.4 V (Charging)	Passed	
SPE00150:SPT00107	12.3 V	8.3 V (Charging)	Passed	
SPE00150	15.1 V	8.3 V (Charging)	Passed	

Squib resistance check											
Group	Channel	DAS	Ch #	Delay	Dur...	Fire Test Status	Low (Ω)	High (Ω)	Resistance (Ω)	Status	Setting
Group 1	Standard Front Airbag Primary	SPE00150:SPT00107	SQ-01	17.00	10.00	Passed	0.9	8.0	3.66	Passed	---
Group 1	Standard Front Airbag Secondary	SPE00150:SPT00107	SQ-02	20.00	10.00	Passed	0.9	8.0	3.64	Passed	---

Event lines check			
DAS	Start	Trigger	Status
SPE00150:SP500331	<input type="checkbox"/>	<input type="checkbox"/>	Passed
SPE00150:SPT00107	<input type="checkbox"/>	<input type="checkbox"/>	Passed
SPE00150	<input type="checkbox"/>	<input type="checkbox"/>	Passed

Tilt sensor check						
DAS	System ID	System Location	X-axis Denom	Y-axis Denom	Z-axis Denom	Status

DAS: 003 Comm User Admin navigated to: Record_ArmChecklist Connected to: Local Current view: Admin Login: Admin

a. If enabled, the Arm Checklist will run system tests as defined in the Test Setup.

NOTE: If a TOM is included in the hardware used in the test, the Arm Checklist is automatically included.

11. Continue to the **Arm** navstep:

The screenshot shows the DataPRO software interface. The sidebar on the left has the 'Arm' option highlighted with a red arrow. The main display area shows the following information:

Example Test Setup - 2020_01_23 12_01

Recording Mode: Circular buffer Samples Per Seconds: 10,000 Channels: 12 (8 analog, 2 SQUIB, 0 digital input, 2 digital output)
Pre-Trigger Seconds: 1.00 Post-Trigger Seconds: 1.00 Level Triggers: None

Waiting for user selection

Trigger: waiting Faults: clear

Group	DAS	Test sample rate	Input Voltage Status	Battery Voltage Status	Time left in arm	Triggered	Faults	Status
Group 1	SPE00150	---	15.1 V	8.3 V (Charging)				
Group 1	SPE00150:SPS00331	10,000						
Group 1	SPE00150:SPT00107	10,000						
Test channels	SPE00150	---	15.1 V	8.3 V (Charging)				
Test channels	SPE00150:SPS00331	10,000						

- Confirm Test Setup, Test ID, recording mode and parameters, channel count, group(s) and associated DAS.
- Verify Input Voltage (if present) and Battery Voltage (if present).
- System status displays.
 - “Waiting for user selection”: Select Run to arm the system.
 - “Trigger: waiting” indicates that a trigger has not been received.
 - “Faults: clear” indicates that no faults have been detected.

NOTE: If enabled, additional Arm Prepare navstep will be present. See Appendix D: Quick Arm for more information.

12. Select Run to arm the system.
 - a. Circular Buffer recording mode:

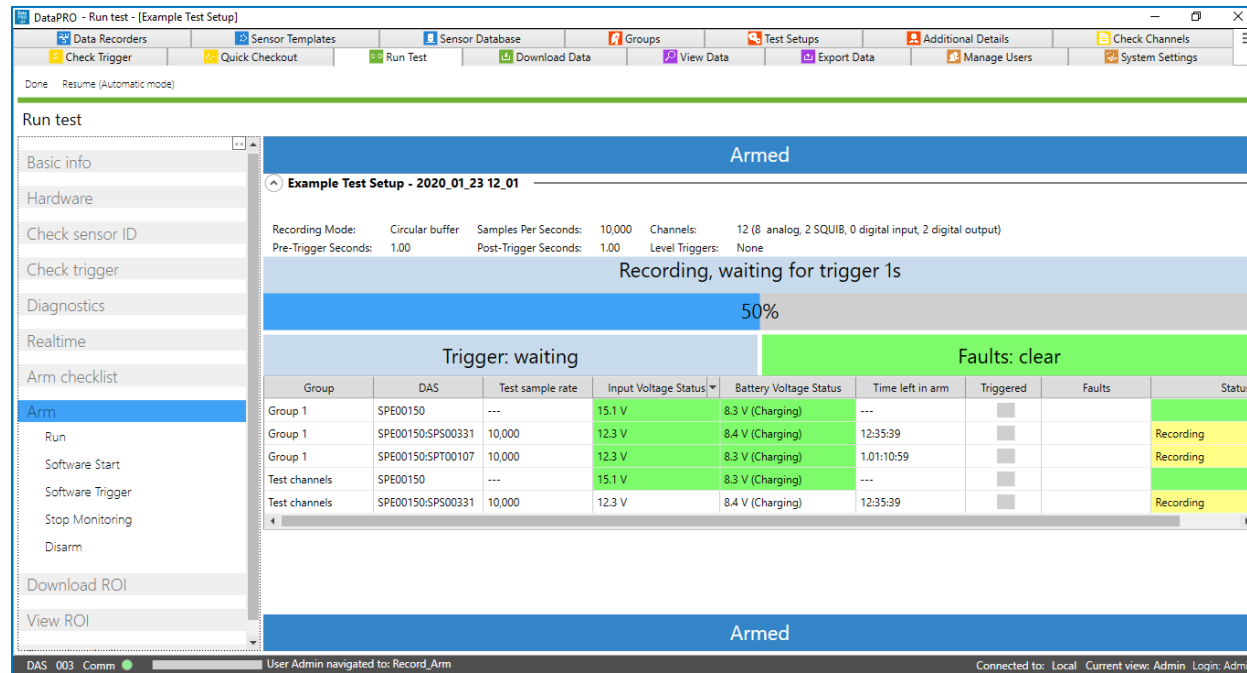

- i. Once armed, status bar indicates recording, waiting for trigger. Displays time left in pre-defined test parameters.
- ii. Time left in arm is only displayed for SLICE hardware and displays total time available on 16 GB internal memory (See [How to Calculate Maximum Recording Time](#), page 24, for more information).
- iii. Each DAS reports individual status.
- iv. Select Software Trigger to apply a software trigger.

- v. Select Stop Monitoring to disconnect the control PC from the DAS for data collection.

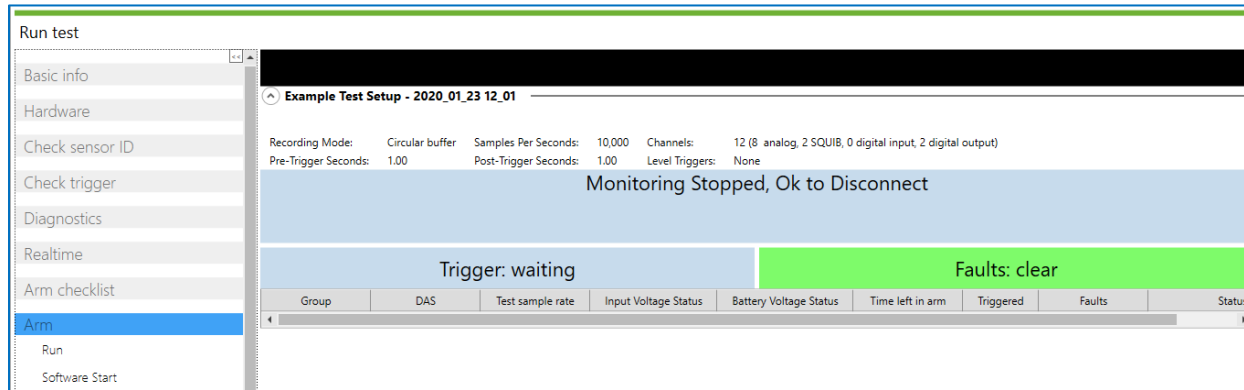

NOTE: Do not disconnect Ethernet or USB communication until the “Monitoring Stopped, OK to Disconnect” message appears.

- vi. Select Disarm to disarm the system and abort the test.

b. Recorder Mode:

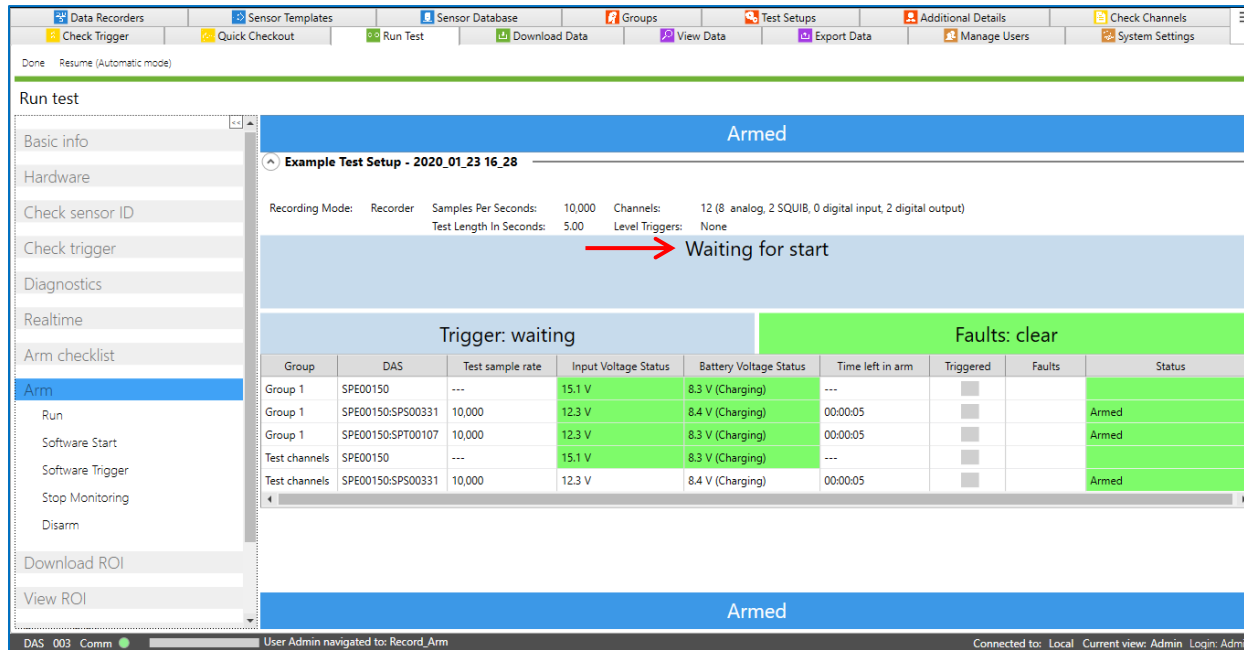

- i. Once armed, status bar indicates Waiting for start.
- ii. Time left in arm displays total test length.
- iii. Each DAS reports individual status.
- iv. Generate Start Record signal either via hardware or by selecting Software Start (Software Trigger will be enabled once DAS receives Start Record signal):

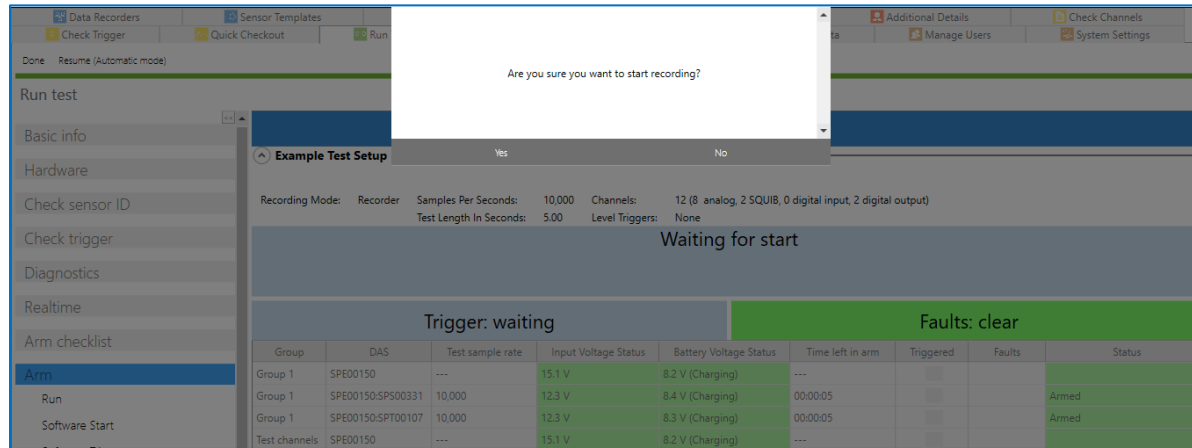

- v. “Time left in arm” will start counting down once Start Record signal has been received:

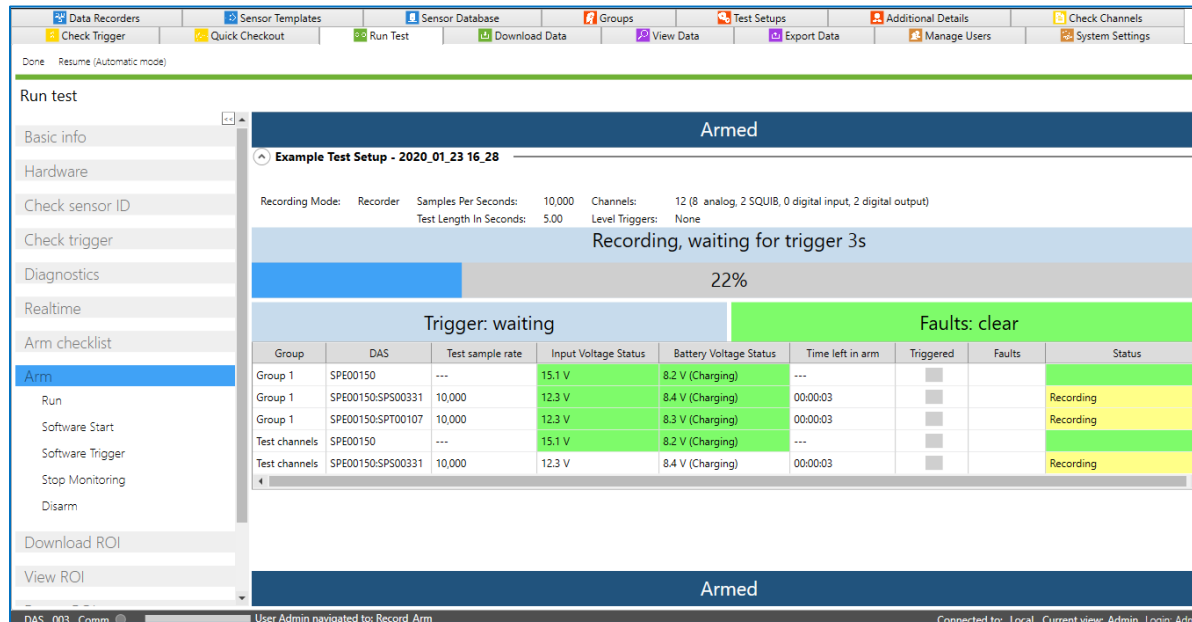

- vi. Generate Trigger/ T=0 signal either via hardware or by selecting Software Trigger.
- vii. Select Stop Monitoring to disconnect the control PC from the DAS for data collection.

NOTE: Do not disconnect Ethernet or USB communication until the “Monitoring Stopped, OK to Disconnect” message appears.

- viii. Select Disarm to disarm the system and abort the test.

c. Hybrid Mode:

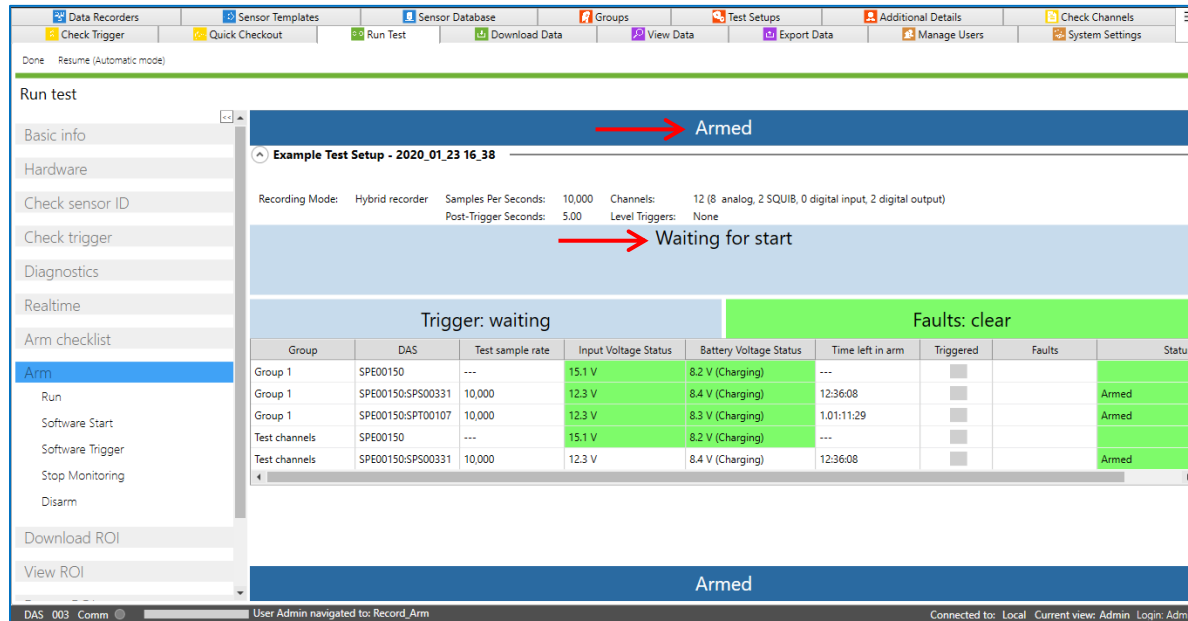

- i. Status bar indicates Waiting for start.
- ii. Post-Trigger Seconds displays total test length defined in Test Setup. Time left in arm displays total record time based on available DAS memory.
- iii. Each DAS reports individual status.
- iv. Select Software Start to apply a software Start Record signal (Software Trigger will be enabled once DAS receives Start Record signal).

- v. Time left in arm begins counting down once Start Record signal is received. Data is being written to flash memory and will be included in “Download All” dataset:

Recording Mode: Hybrid recorder Samples Per Seconds: 10,000 Channels: 12 (8 analog, 2 SQUIB, 0 digital input, 2 digital output)
 Post-Trigger Seconds: 5.00 Level Triggers: None

Recording, waiting for trigger 5s
0%

Trigger: waiting Faults: clear

Group	DAS	Test sample rate	Input Voltage Status	Battery Voltage Status	Time left in arm	Triggered	Faults	Status
Group 1	SPE00150	---	15.1 V	8.2 V (Charging)	---	<input type="checkbox"/>		
Group 1	SPE00150:SPS00331	10,000	12.3 V	8.4 V (Charging)	12:35:28	<input type="checkbox"/>		Recording
Group 1	SPE00150:SPT00107	10,000	12.3 V	8.3 V (Charging)	1.01:10:49	<input type="checkbox"/>		Recording
Test channels	SPE00150	---	15.1 V	8.2 V (Charging)	---	<input type="checkbox"/>		
Test channels	SPE00150:SPS00331	10,000	12.3 V	8.4 V (Charging)	12:35:28	<input type="checkbox"/>		Recording

vi. Specified Post-Trigger Seconds begins counting down once Event signal has been received:

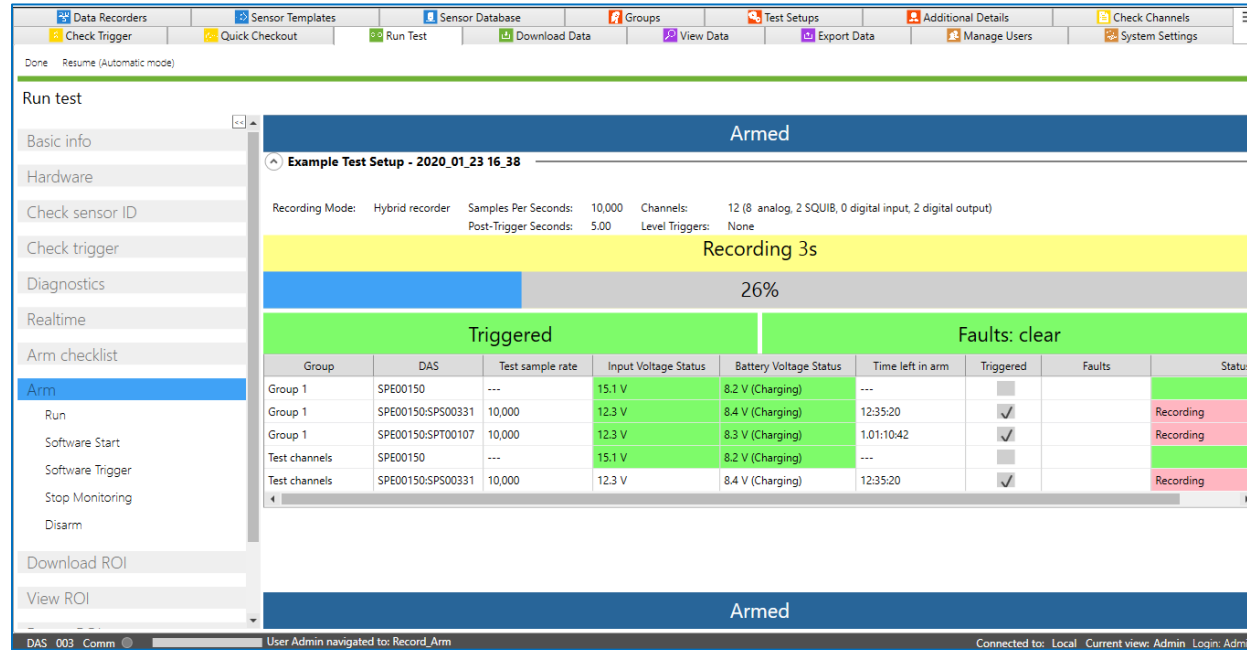

vii. Select Stop Monitoring to disconnect the control PC from the DAS for data collection.

NOTE: Do not disconnect Ethernet or USB communication until the “Monitoring Stopped, OK to Disconnect” message appears.

viii. Select Disarm to disarm the system and abort the test.

- d. When attached to a SLICE6 AIR with more than one event present, an additional Download and Rearm option appears in the Arm menu. This option will disarm the device, download all events present, and then re-arm the device.

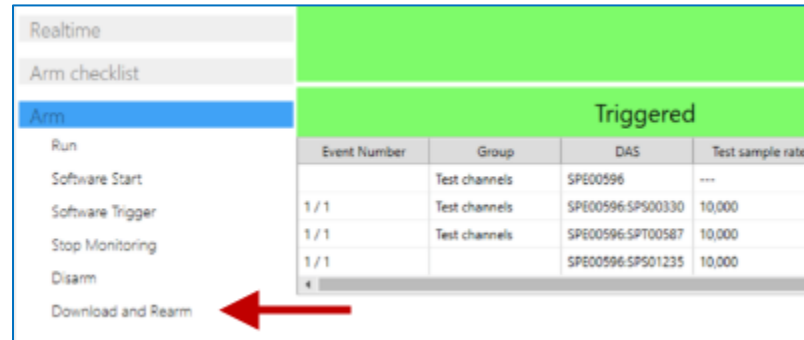

13. When the test is complete and DAS has been detected (if applicable) select the **Download ROI** –or– **Download all** navstep. Skip to step 15 to proceed with Download All. Continue to the next step to proceed with Download ROI:

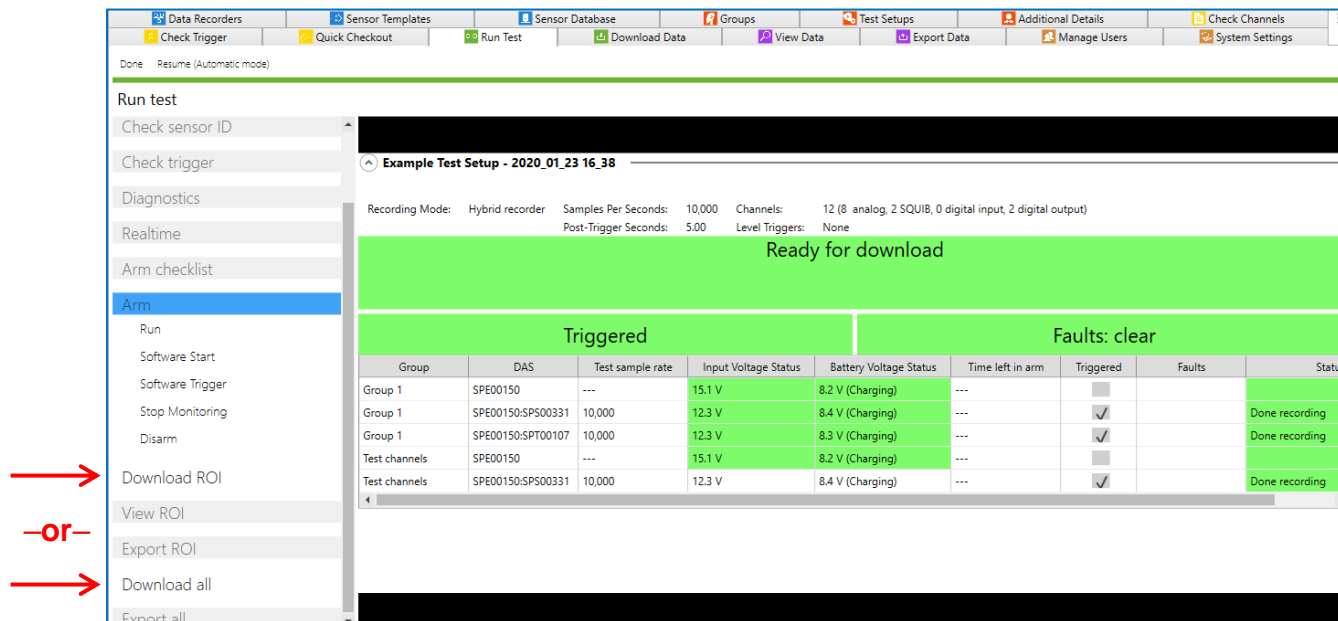

- a. Download and export options are configurable for each Test Setup (See [Test Setups](#), page 83, for more information).

NOTE: DataPRO will indicate if squib resistance is still present or TOMs are not in “Safe Position”. See Settings Manual for options to configure DataPRO to allow or prevent progression:

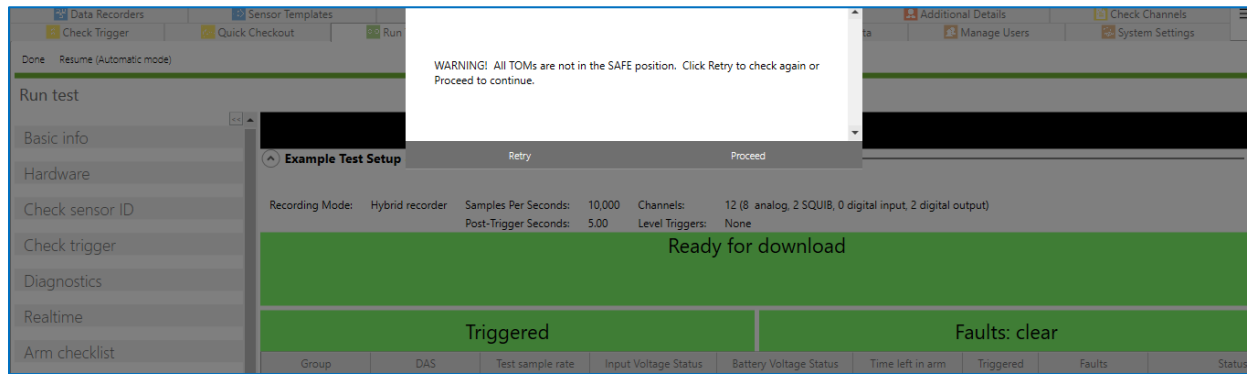

14. Modify the ROI period start/end if desired:

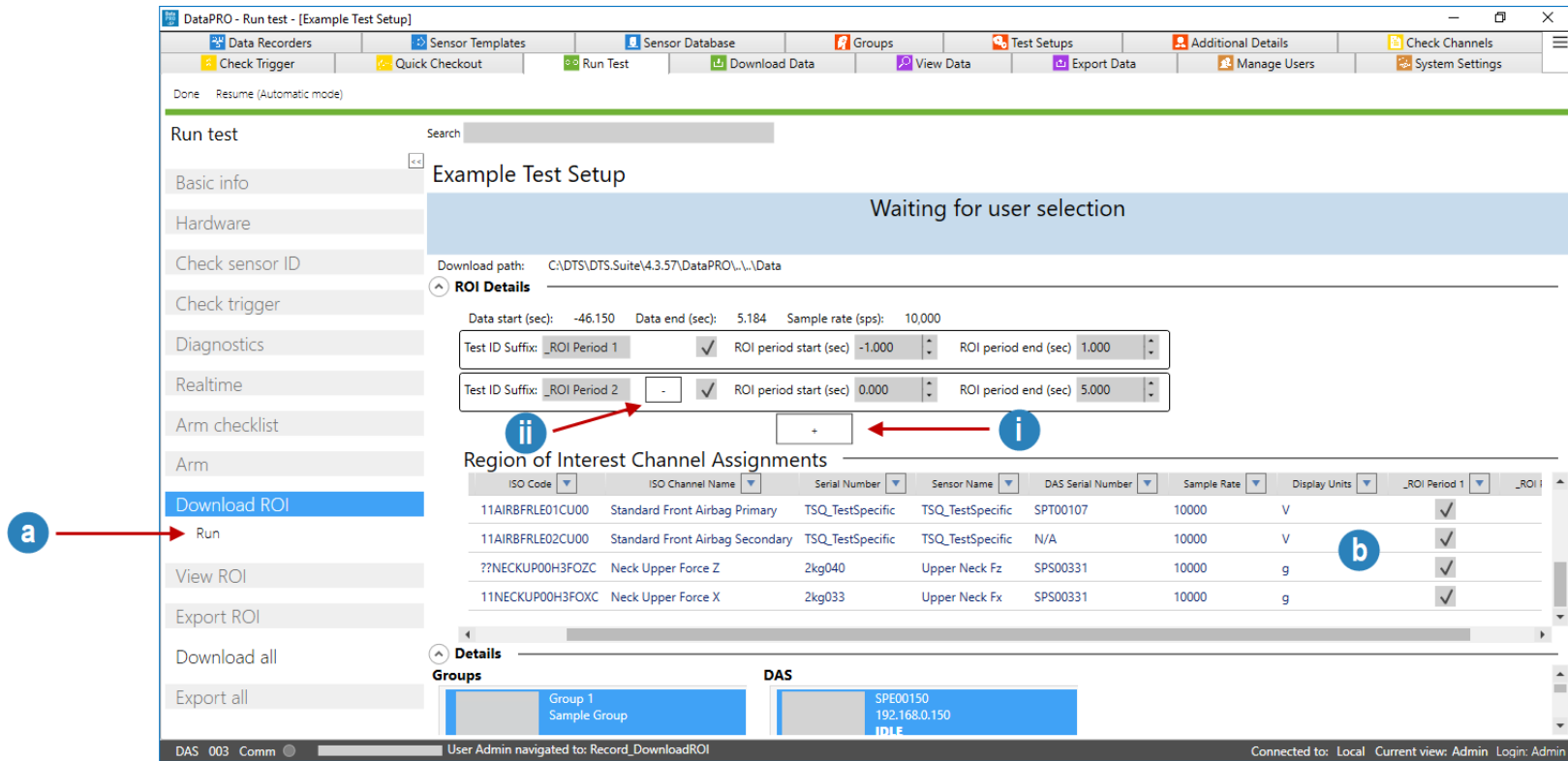

- a. Select Run to download the defined ROI Segment(s).
 - i. Add additional ROI Segment(s) with the plus (+).
 - ii. Remove ROI Segment(s) with the minus (-).
- b. If multiple ROIs are included, channels to be included in each ROI must be defined.
 - i. Each channel in a test must be included in at least one ROI.

15. Select View ROI (optional) to display the downloaded data in the Region Of Interest:

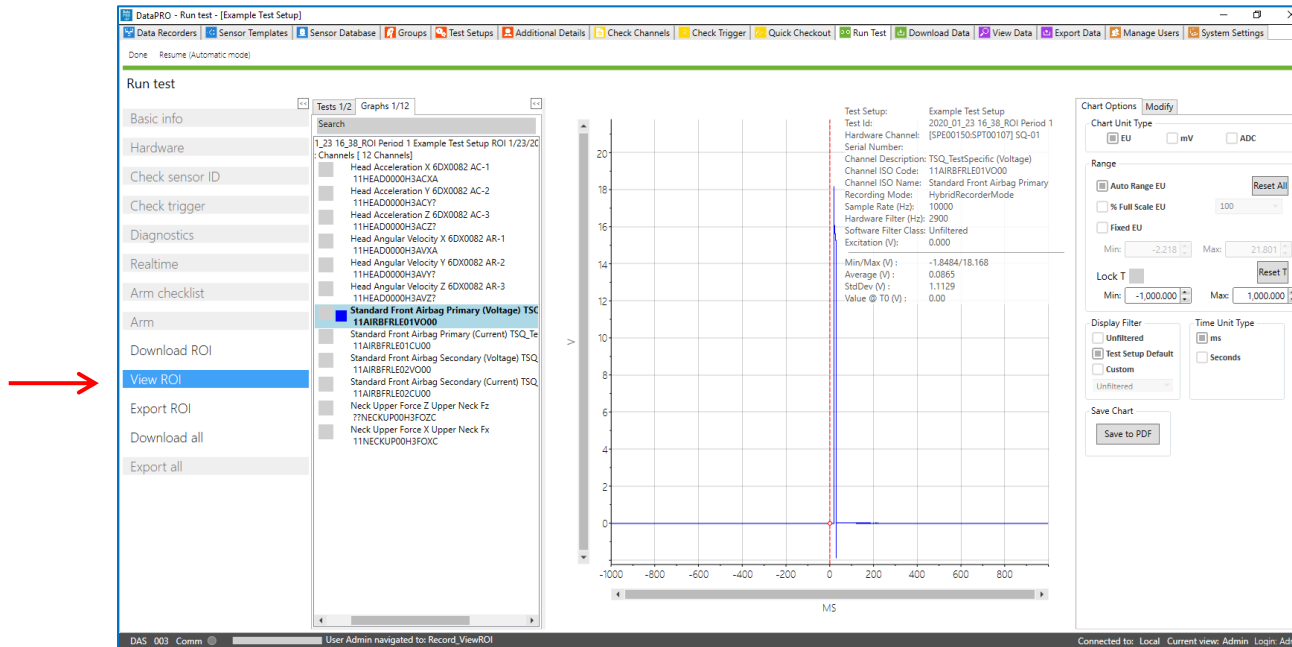

- a. The data set(s) displayed in the View ROI Test Selection pane are the ROI Segment(s) just downloaded.
- b. See View Data, page 175, for information on Viewer controls.

16. Select Export ROI to export the downloaded data in the ROI Segment(s) (Optional):

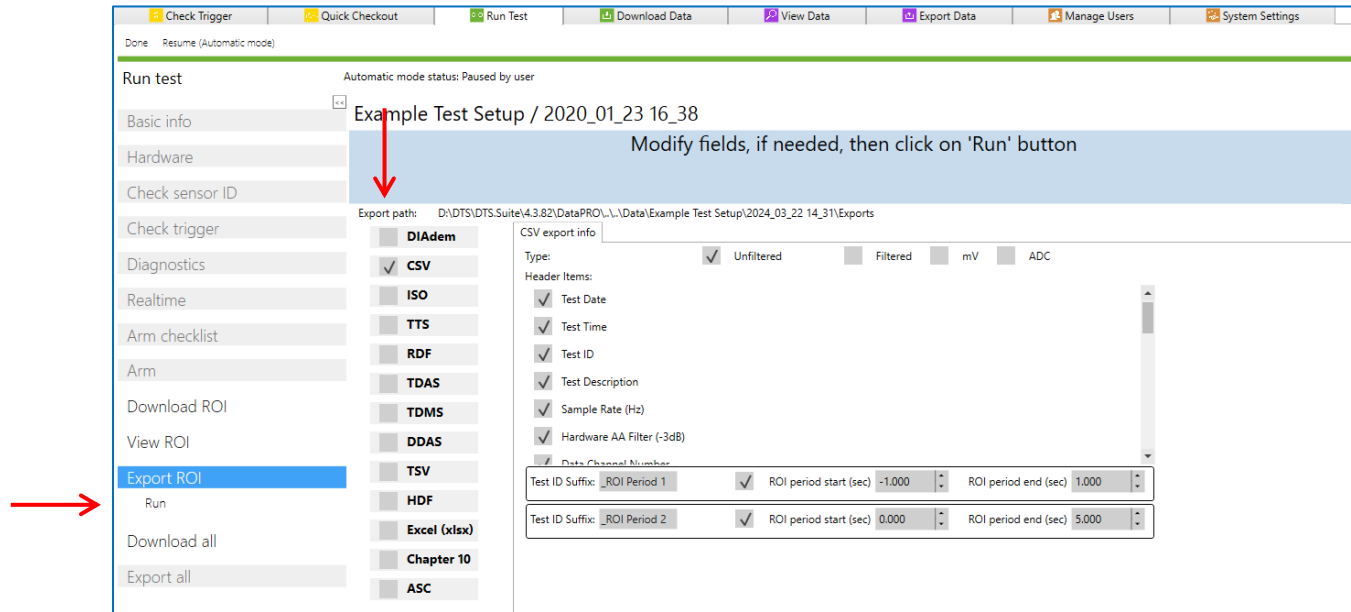

- a. Add or remove export types and configure as needed.
- b. Select Run to export ROI data.

17. Select Download all then Run to download the full data set (Optional):

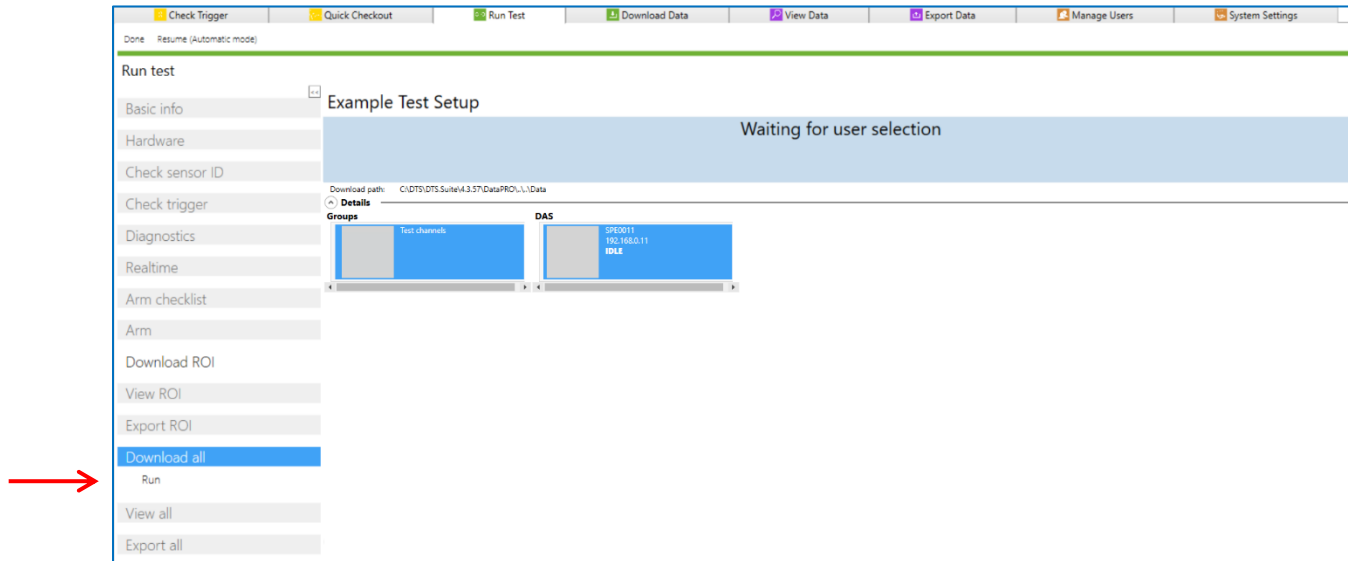

18. Select View All to display the full data set (Optional)

- a. The data set displayed in the View All Test Selection Pane is the full data set just downloaded.
- b. See [View Data](#), page 175, for information on Viewer controls.

19. Select Export all to export the full data set (Optional)

- a. Add or remove export types and configure as needed.
- b. Select Run to export all data (See

c. [Appendix E: DataPRO File Structure](#), page 275).

20. Select “Done” to return to the previous location. To return to the [Quick Start](#) steps, go back to page 32.

NOTE: Automatic mode is enabled in the Test Setup used for the images used above.

Download Data

Use the Download Data tab to re-download a data set that has already been collected and is still present on the DAS internal memory.

1. Ensure the correct Test Setup is selected as the Active Test Setup.
2. Select the “Download Data” tab:



3. Select Show recovery tools to browse to test setup if necessary.
4. Modify the Test id if desired.
 - a. DataPRO defaults to using the most recently run Test Setup .xml file when downloading data via the Download Data tab.

- b. If a different Test Setup is desired, select Show Recovery Controls to browse to and use a different Test Setup .xml file:

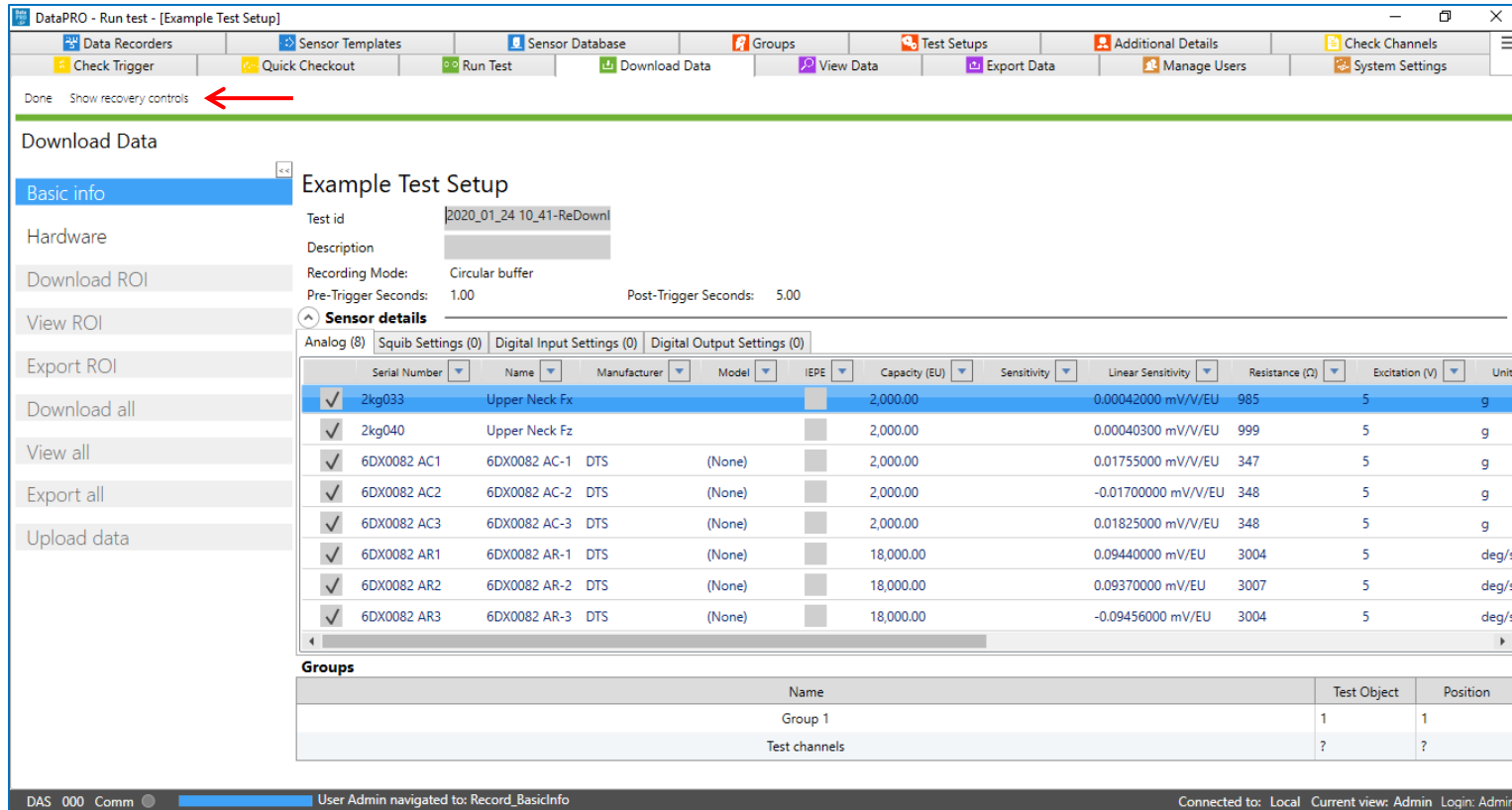

- Continue to the **Hardware** navstep.
- Continue from step 11 above under Run Test, page 148.

Review

View Data

Review a data set that has been collected and downloaded with any version of DataPRO. Perform basic manipulations of data channels, add calculated channels, or modify certain parameters for the full data set.

To view data from a test not listed in the table, start at step 1.

To view data from a test in the table, see [Selection Pane](#), page 182.

Viewer Layout

The viewer is divided into three panes:

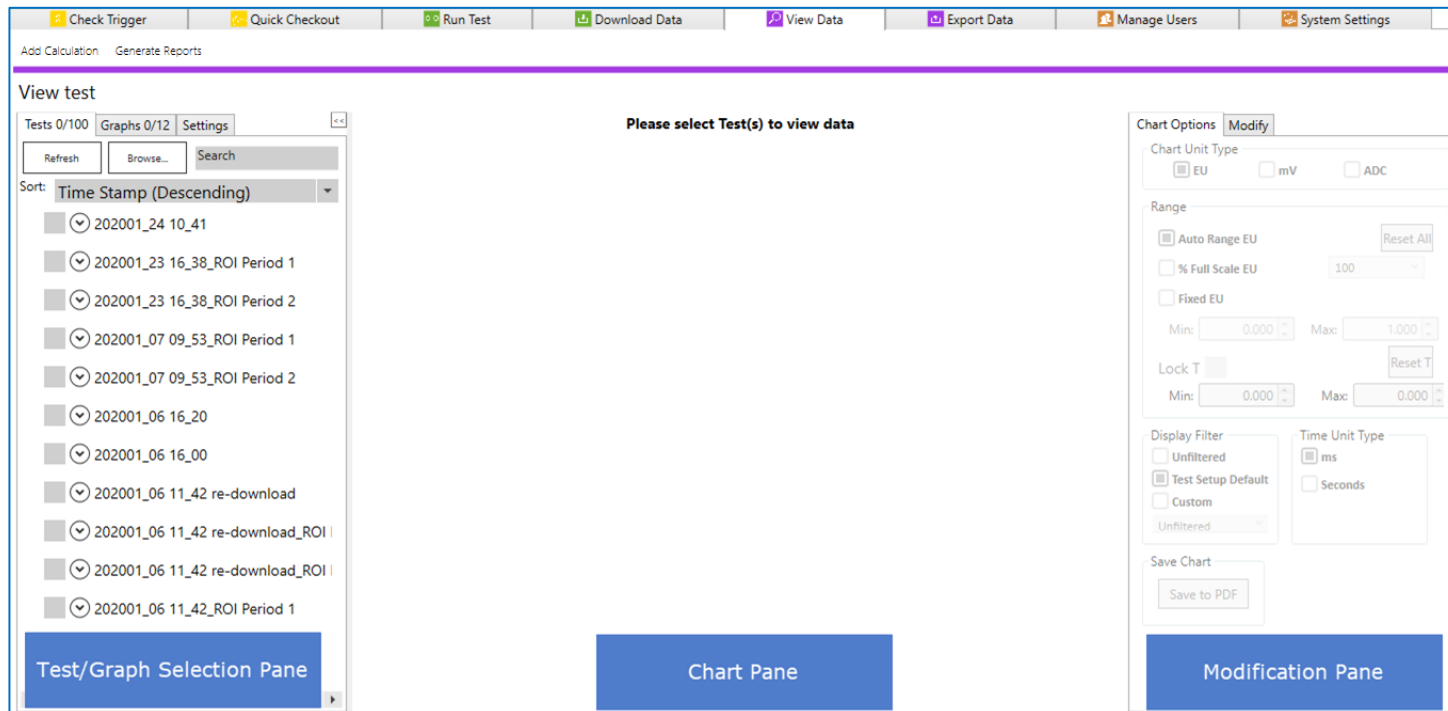

1. Test/Graph Selection Pane (See [Selection Pane](#) for more details).
 - a. Test Selection:

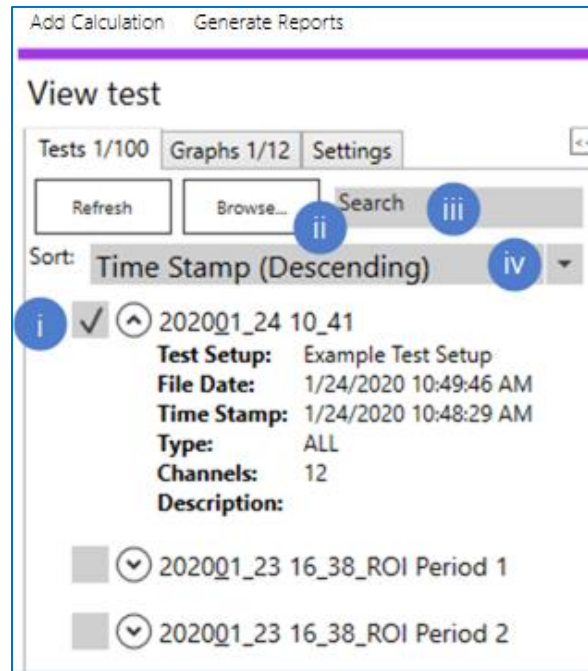

- i. Select tests from data directory.
- ii. Browse to other datasets.
- iii. Search for text in test descriptors.
- iv. Sort display order of data.

b. Graph Selection:

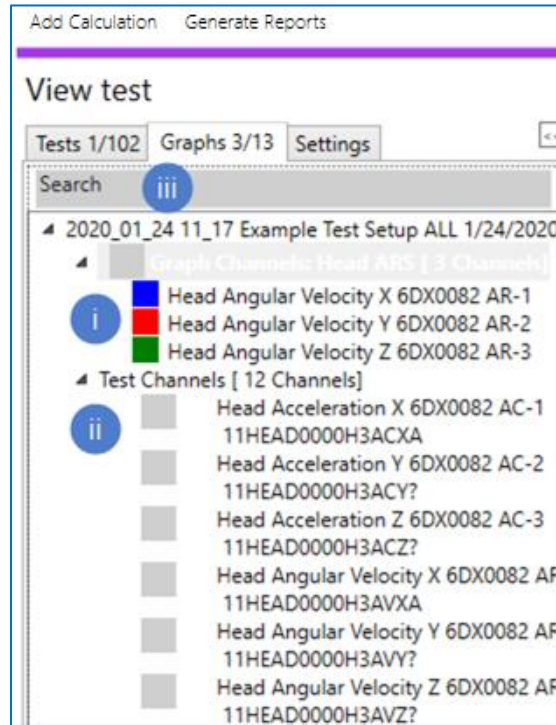

- ii. Select pre-defined graphs, individual channels or calculated channels to display.
- iii. Select/lock multiple channels to chart to dynamically review and compare.
- iv. Search for channel(s) by Channel name or Channel description.

c. Settings:

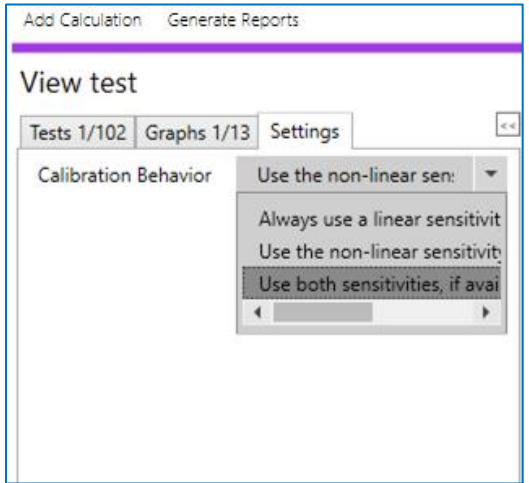

- i. Select Calibration Behavior for any dual-calibration sensors in a test (sensors that include both a linear and a non-linear definition).
- "Always use a linear sensitivity" will only use the linear calibration in the viewer.
 - "Use the non-linear sensitivity if available" will only use the non-linear calibration in the viewer.
 - "Use both sensitivities, if available" will show both linear and non-linear calibrations as separate channels.

2. Chart Pane (See [Chart Pane](#), page 190, for more details):

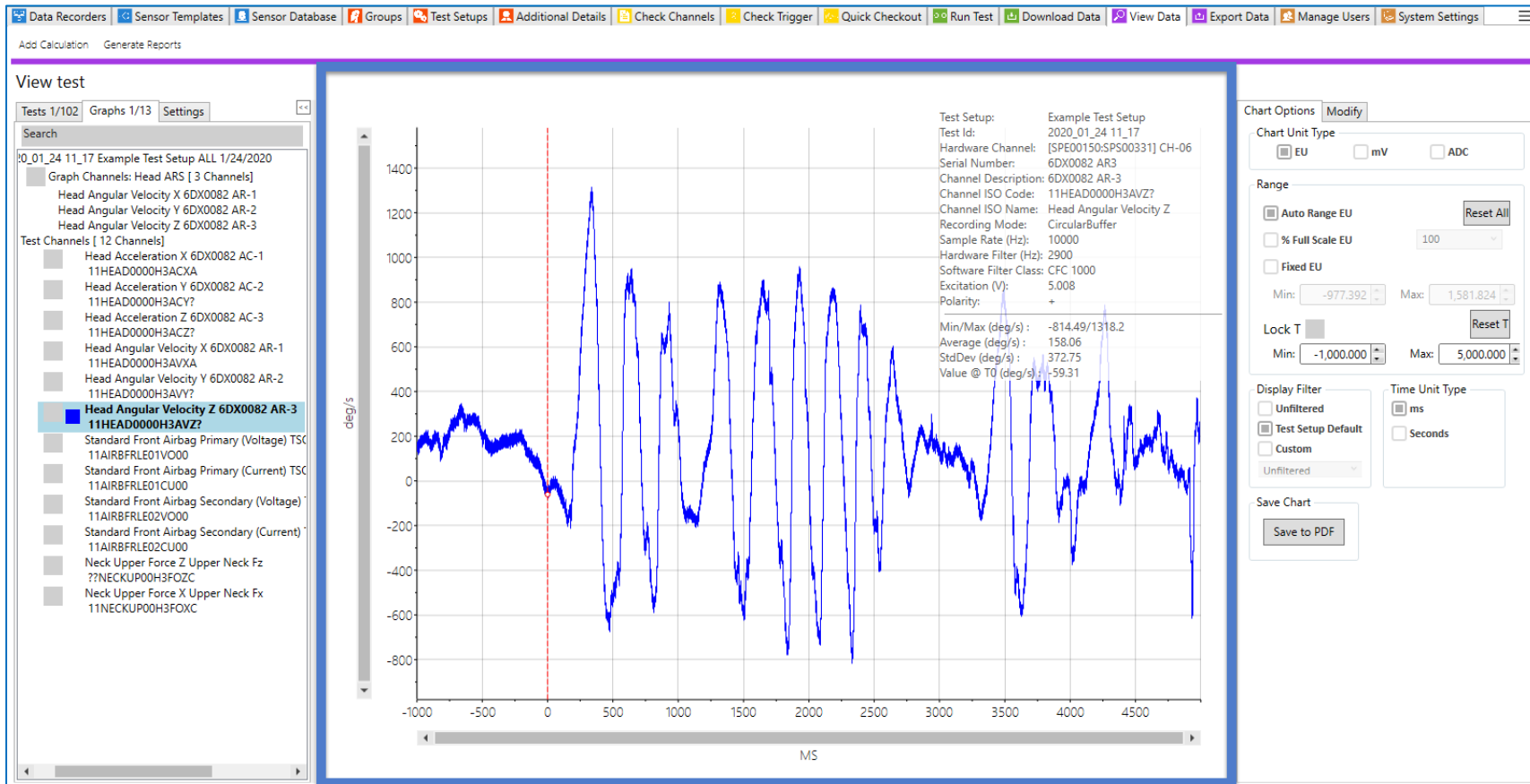

- Select channel(s) to review test data.
- Dynamically zoom as desired by clicking and dragging a box around the area to zoom in on.
- Use Modification Pane to manipulate chart display or write modifications to test data.

3. Modification Pane (See [Modification Pane](#), page 193, for more details):

The screenshot shows the 'Chart Options Modify' pane. It includes sections for 'Chart Unit Type' (EU, mV, ADC), 'Range' (Auto Range EU, % Full Scale EU, Fixed EU, Min/Max values, Lock T, Reset All, Reset T), 'Display Filter' (Unfiltered, Test Setup Default, Custom), 'Time Unit Type' (ms, Seconds), and 'Save Chart' (Save to PDF).

The screenshot shows the 'Chart Options Modify' pane with detailed channel configuration. It includes fields for Description (6DX0082 AR-3), Filter (CFC 1000), Data Flag (Normal), Shift T₀ (ms) (0.000), EU Multiplier (1.00000000), EU Offset (0.00000000), Sensitivity (-0.09456000000), Line Fit, T₁ (ms) (0.000), and T₂ (ms) (0.000). Buttons for Cancel, Write, and Restore All are visible at the bottom.

- a. Chart Options tab allows for real-time manipulation of the channel(s) displayed in the chart.
 - i. Select Save to PDF to save the current graph as a PDF. The PDF is currently saved with the binary data.

- ii. [Appendix E: DataPRO File Structure](#), page 275.
- b. Modify tab allows for single-channel modifications that are written to the data.
- i. Multiple modifications can be made to each channel.
 - ii. Restore All will undo all changes and revert data to original, as collected values.

Selection Pane

Tests tab

Select test(s) to review individual channel data:

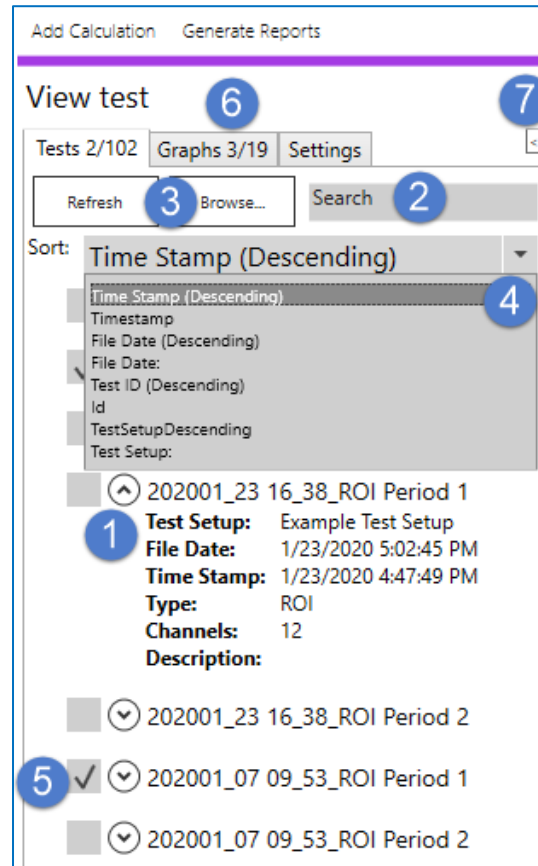

1. Use arrows to expand/collapse test description.
2. Search for test descriptors (Test Setup, Test ID, Type, Description, etc.).
3. Browse to dataset(s) in other locations.
 - a. DataPRO and SLICEWare data can be imported and viewed.

4. Sort datasets by Time Stamp, File Date, test ID, Test Setup.
5. Select dataset(s) from DataPRO data directory.
 - a. Selecting a dataset adds the channels (individual test channels, pre-defined graphs and calculated channels) to the Graphs tab.
6. Tests tab displays number of tests selected/number of tests available. Graphs tab displays number of graphs displayed/number of graphs available.
7. Use snap arrows to expand/collapse menu.

Graphs tab

Select channels (pre-defined graphs, individual test channels and calculated channels) to display and review:

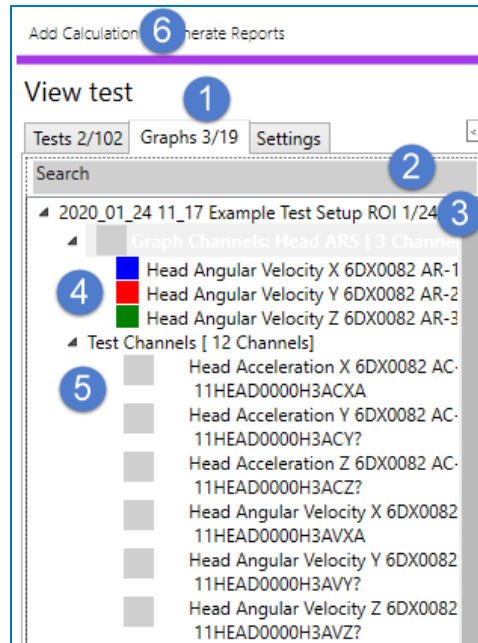

1. Channels (individual test channels, pre-defined graphs and calculated channels) from selected test(s) are displayed in the Graphs tab.
 - a. Selected/locked channels displayed in numerator (**3/19**).
 - b. Available channels displayed in denominator (**3/19**).

2. Search for channel name, channel description, or channel code.
3. Test Setup name/Test ID for test(s) selected in Tests tab.
 - a. Expand or collapse test ID to hide or display available channels.
4. Pre-defined graphs will be displayed first.
5. Select individual channels, pre-defined graphs, or calculated channels.
 - a. Select channels by highlighting description.
 - b. Lock channels to chart with checkbox.
6. Select Add Calculation to add a Calculated Channel:

View test

Add Calculated Channel

Channel Name: New Channel

ISO Code: NONE

Calculation: Integral

Calculation Input Channel: 6DX0082 AC-1

- a. Enter Channel name and (optional) ISO Code.

- b. Select Calculation type and included channels:
 - i. Coefficients for 3D IR-TRACC calculations can be found in the *DataPRO.exe.config* file.

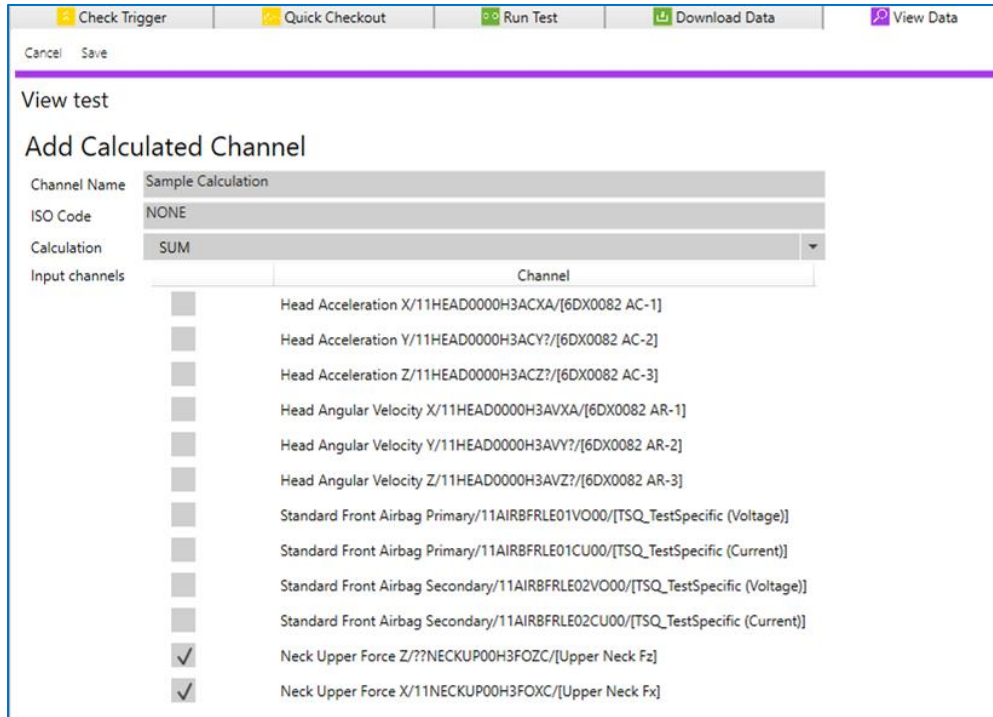

c. Select Save to add calculated channel to dataset.

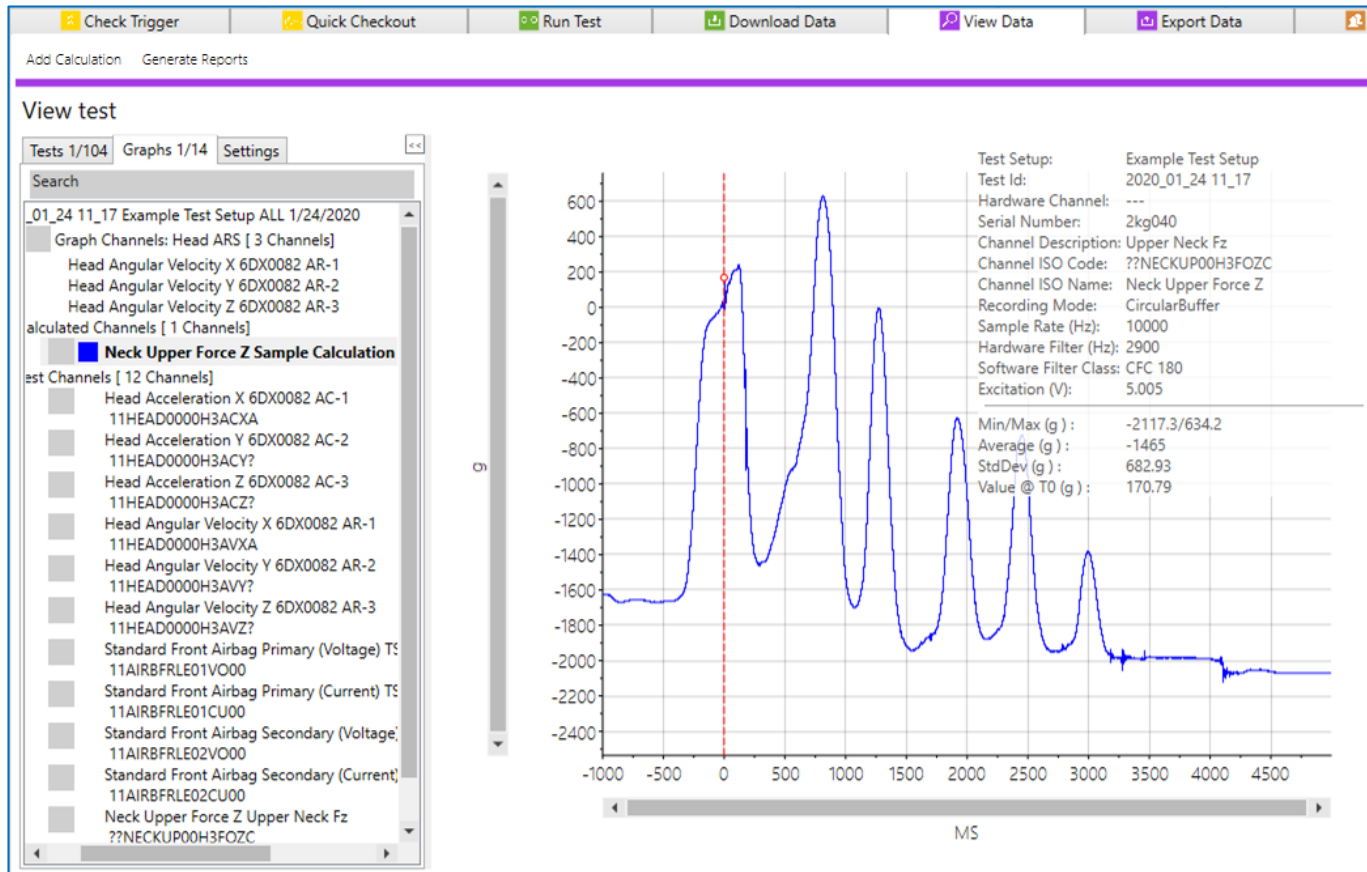

Graph Selection

1. Selecting a dataset adds the channels (individual test channels, pre-defined graphs, and calculated channels) to the Graphs tab:

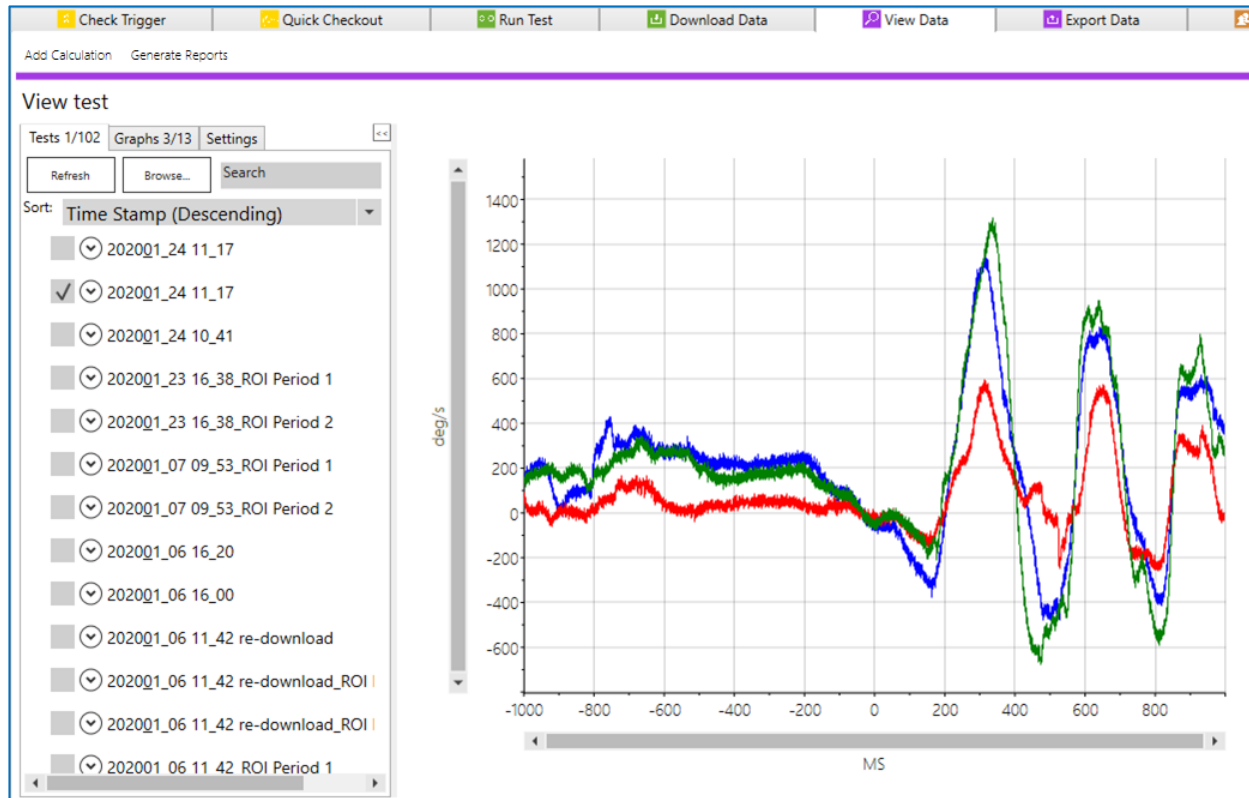

2. Selecting a channel adds that graph to the chart:

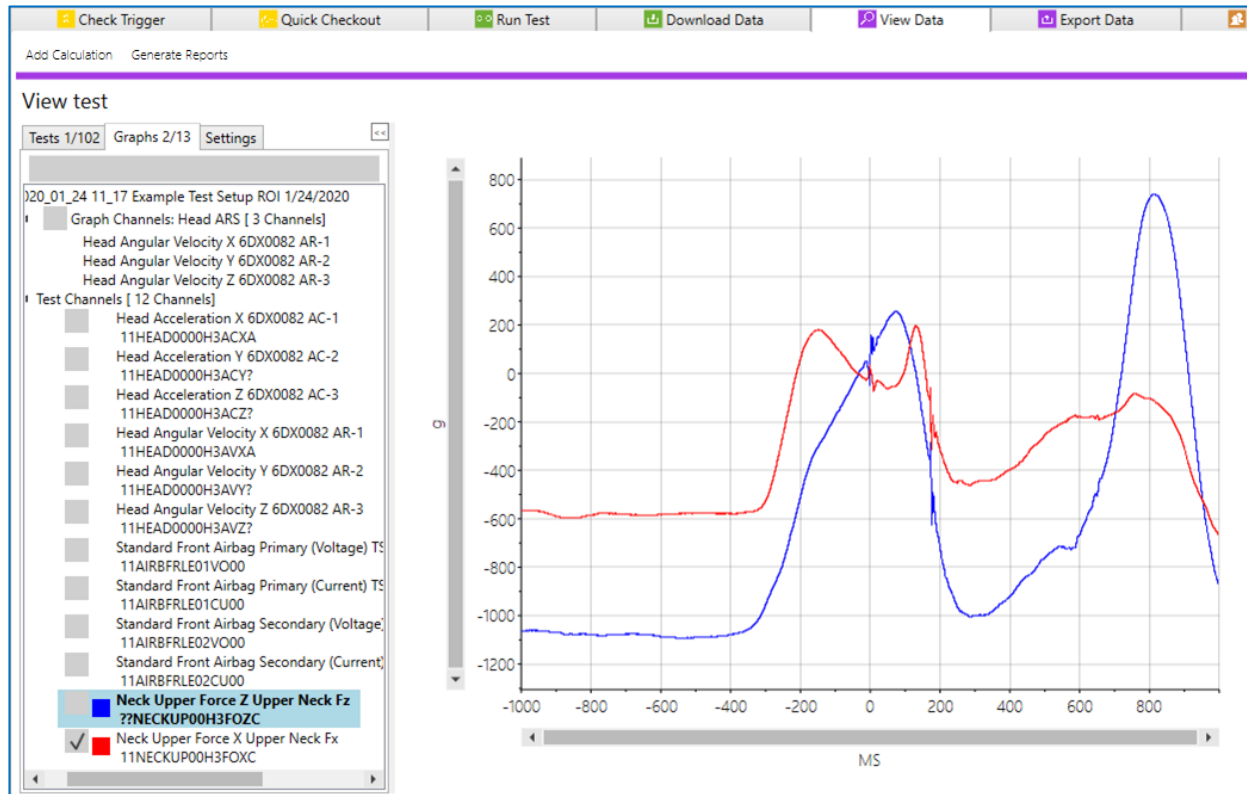

- a. If a test contains predefined graphs, these will be displayed first in the Chart pane. If there are no predefined graphs, the first channel in the test will be displayed.
- b. A single channel, predefined graph, or calculated channel can be selected and displayed in the chart or locked to the chart.
 - i. In the above example, Neck Upper Force X is locked to the chart and Neck Upper Force Z is selected.
 - ii. Use the arrow keys or click to change the selected channel.

c. When a single channel is displayed on the chart, channel details will be displayed on the chart:

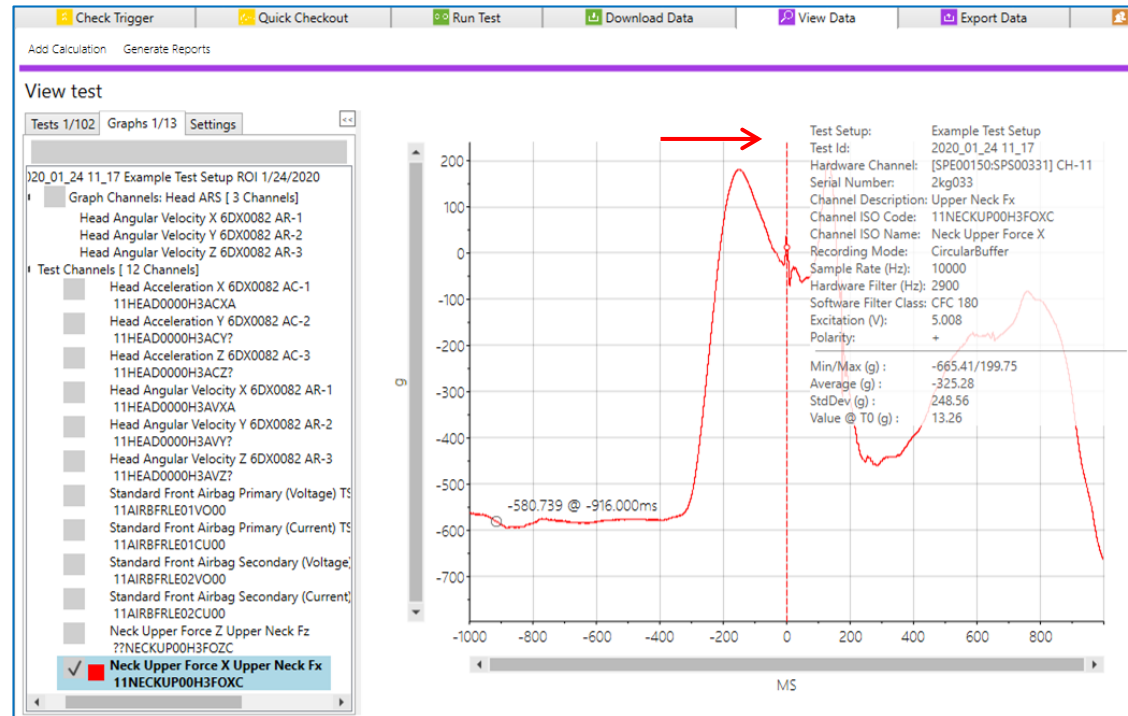

iii. Hover over the channel details to hide.

3. Select the Calibration Behavior for dual-calibration sensors in the Settings tab:

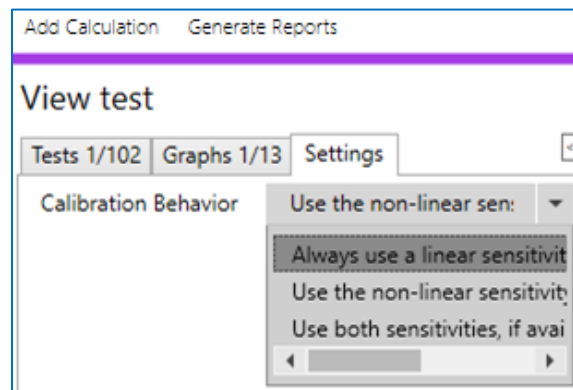
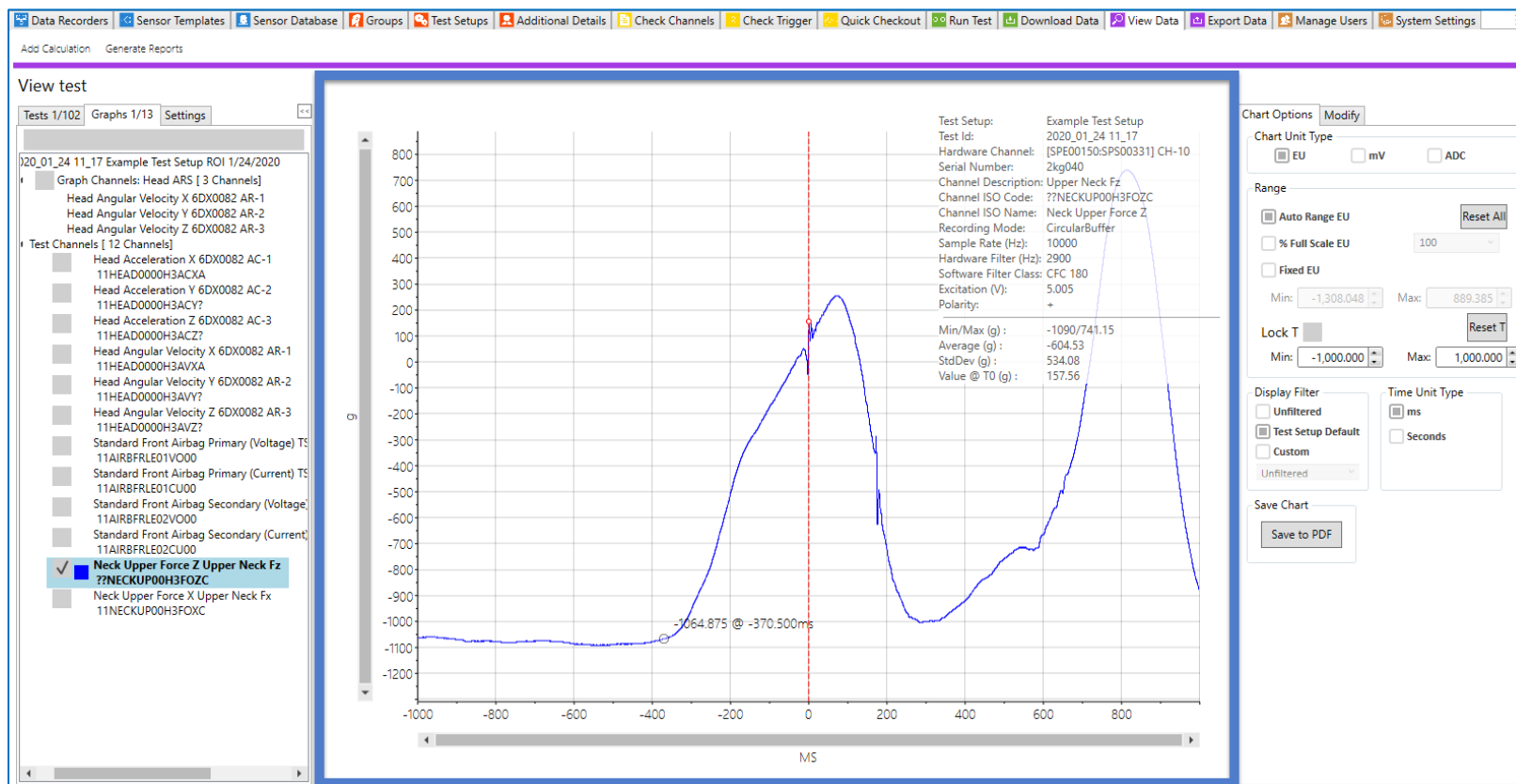

Chart Pane

Selected/locked channels are displayed in the Chart pane:



1. Dynamic Zoom selection:

- a. Click and drag to draw a box around the region to zoom in to.

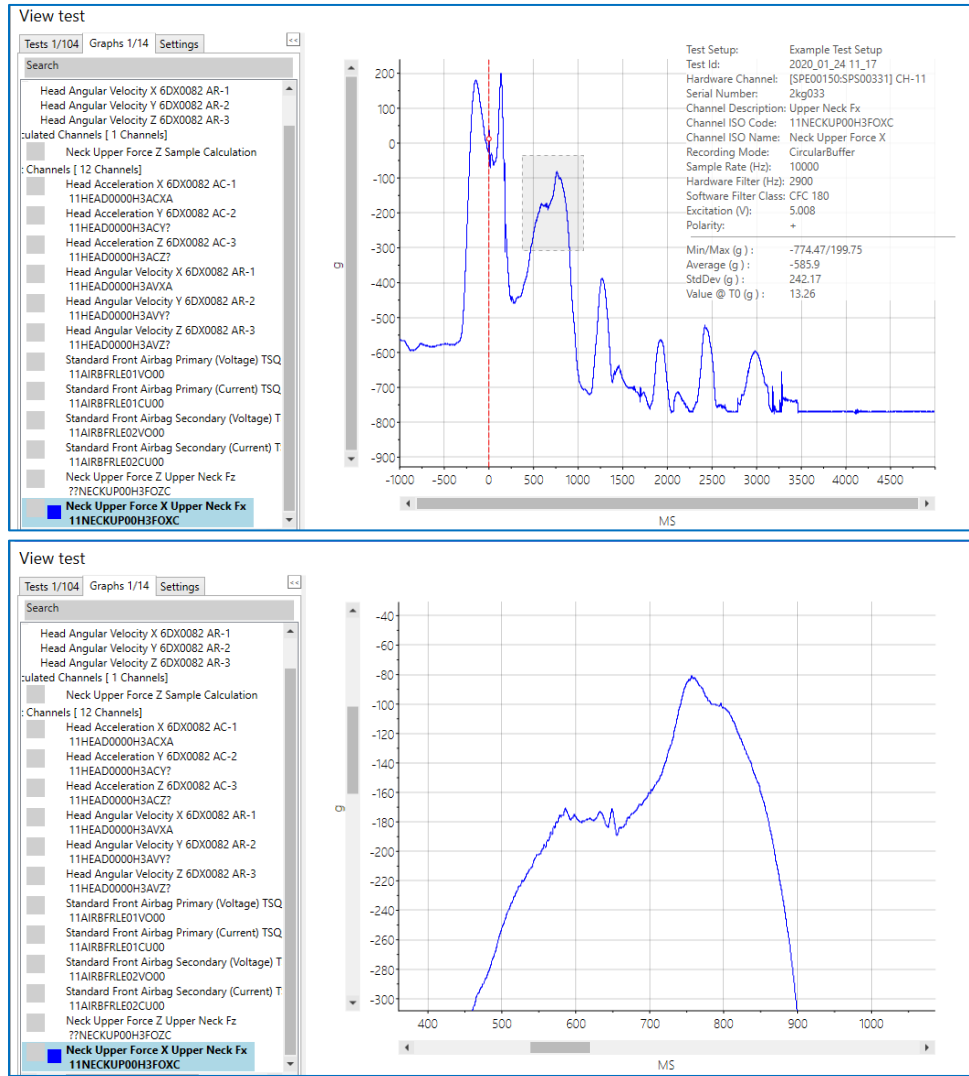

- b. Select Reset All or use ESC key to return to full chart view.

2. Red T=0 indicator:

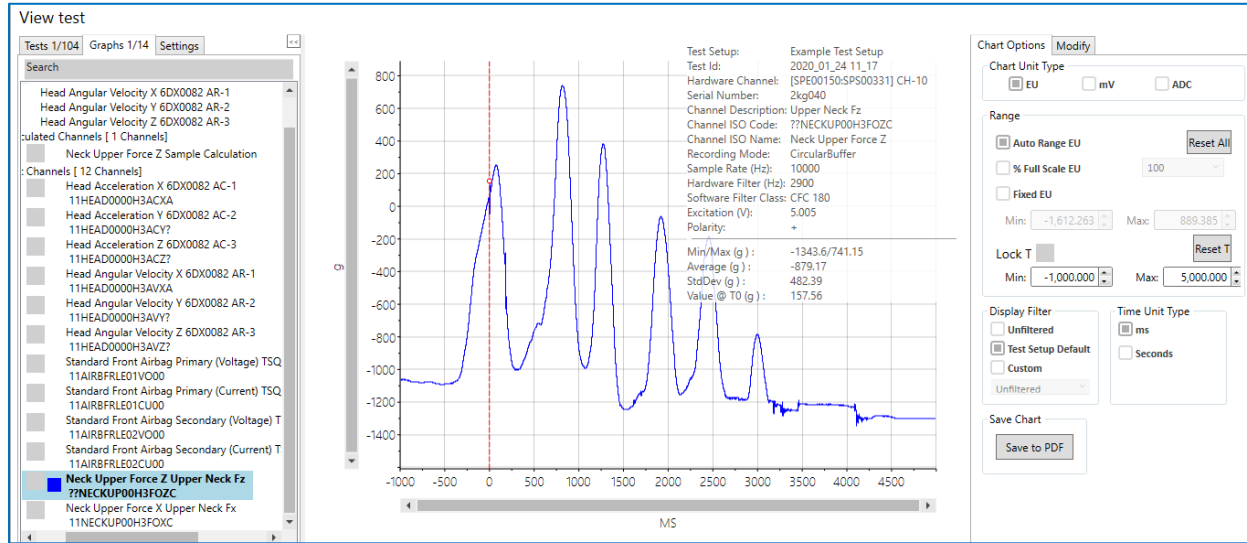

- a. Present when a single channel is displayed.
- b. Move with right mouse click or via entry in Modification pane.

3. Channel overlay:

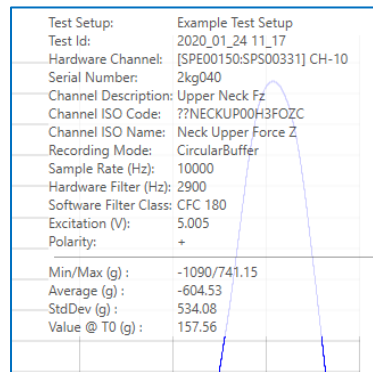

- a. Present when a single channel is displayed.
- b. Hover over to hide channel overlay.

NOTE: When viewing data with total sample count greater than the viewable pixels, data will be presented using the Largest-Triangle-Three-Buckets (or LTTB) algorithm. The basis for the implementation was the example code <https://gist.github.com/DanielWJudge/63300889f27c7f50eeb7>. This algorithm will present the decimated data by preserving peaks and line-fitting unchanging (static) sequences of samples. The algorithm is not applied to exported data.

Modification Pane

Use controls to temporarily modify the displayed view, or to write changes to collected data.

1. Chart Options: Changes made in Chart Options temporarily modify the display view:

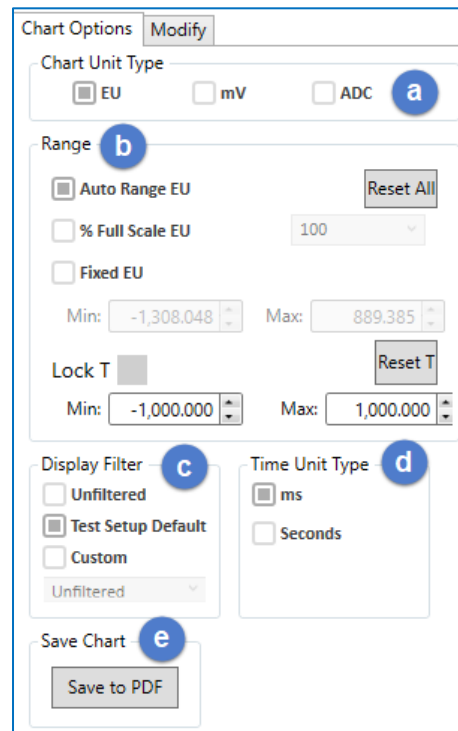

- a. Select to display EU, mV, or ADC as chart unit.
- b. Select Range to display.
 - i. Reset All reverts to Auto Range.
 - ii. Lock T locks X axis at displayed values.

- iii. Reset T reverts X axis to default/full range values.
- c. Select filter type to apply to chart view.
- d. Select to display time in milliseconds or seconds.
- e. Select to save current graph view to PDF. See

- f. [Appendix E: DataPRO File Structure](#), page 275, for more information.
2. Modify: Changes made in Modify can be written to the collected data set:

The screenshot shows a 'Chart Options' dialog box with a 'Modify' tab. The dialog is titled 'Upper Neck Fz'. It contains several fields and buttons:

- Description: Upper Neck Fz
- Filter: CFC 180
- Data Flag: Normal
- Shift T₀ (ms): 0.000
- EU Multiplier: 1.00000000
- EU Offset: 0.00000000
- Sensitivity: 0.000403000000
- Line Fit: T₁ (ms): 0.000, T₂ (ms): 0.000
- Buttons: Cancel, Write, Restore All

- a. Filter: Optionally filter the data by Channel Frequency Class before viewing.
- None
 - CFC 10 – 10-17Hz
 - CFC 60 – 60-100Hz
 - CFC 180 – 180-300Hz
 - CFC 600 – 600-1000Hz
 - CFC 1000 – 1000-1650Hz
 - Unfiltered
- b. Data flag options:
- None
 - Normal
 - Saturated
 - Zero Crossing Error
 - Broken Wire
 - Other

- c. Shift T=0:
 - i. If T=0 indicator is moved with mouse click, new location will be displayed.
 - ii. Enter value to move T=0 indicator.
 - iii. Apply shift to DAS or to test.
- d. Select Cancel to not save changes and revert values.
- e. Select Write to write changes to data.
- f. Select Restore All to revert to original as-collected data.

Generate Reports

The Generate Report option allows you to generate Power Spectral Density (PSD) reports, which display a measurement of a signal's power content versus frequency.

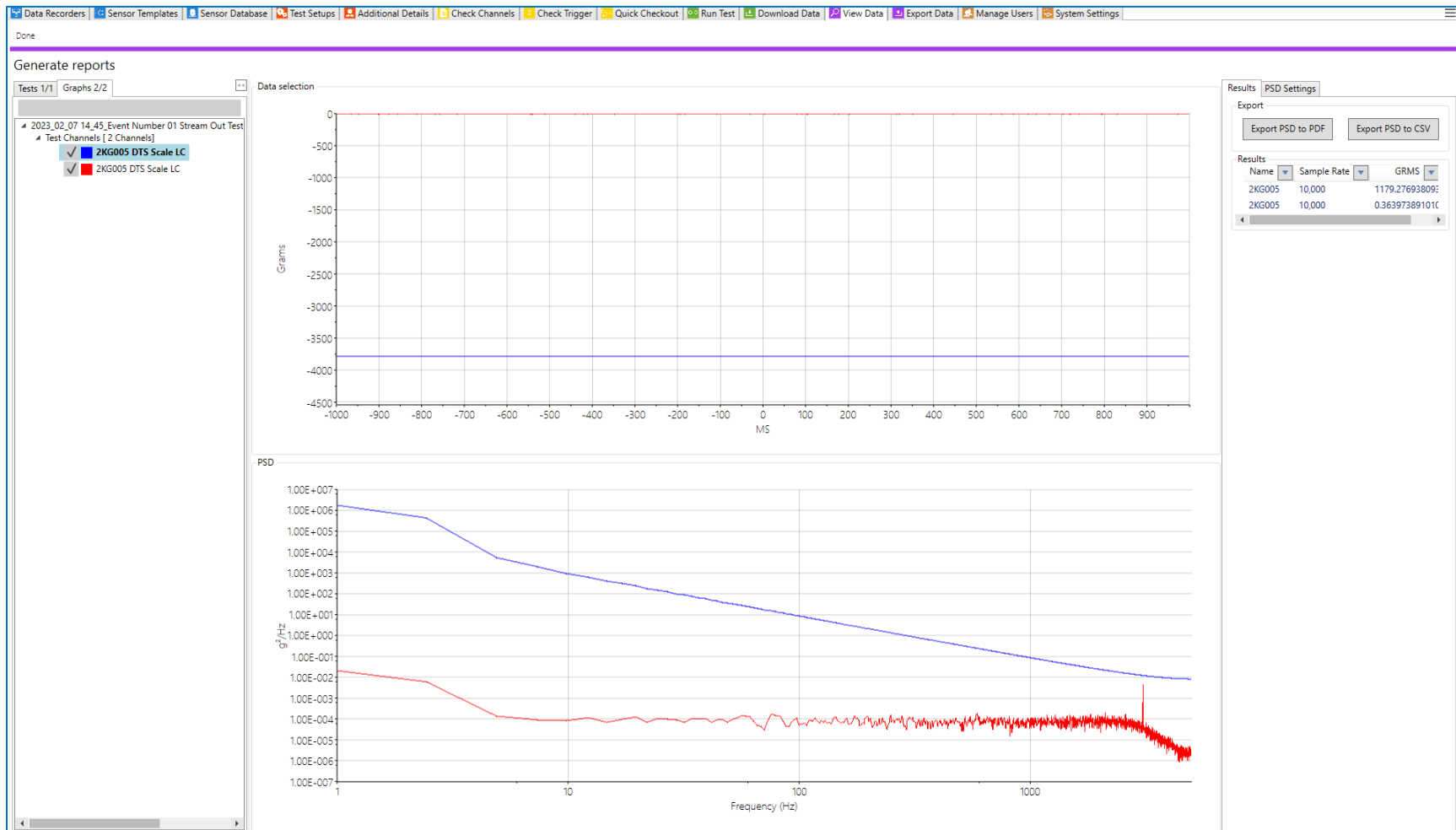

- The **Results** tab on the right allows you to export PSD reports to PDF or CSV.
- The **PSD Settings** tab contains various configuration options for the PSD report.

Export Data

Export a data set that has been collected and downloaded with any version of DataPRO.

- To export data from a test not listed in the table, go to step 2.
- To export a file listed in the table, go to step 4.
- To copy and trim a dataset by start and end times, go to step 9.
- To copy and rename a dataset, go to step 13.

1. Select the “Export Data” tab:

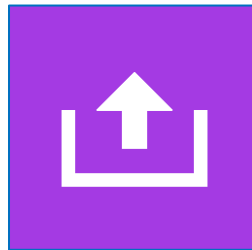

2. To export data collected in DataPRO but not listed in the table, select “Browse”:

Test Setup Name	Test ID	Description	Number of Channels	Test Date/Time	Laboratory	Customer
Example Test Setup	2020_08_20 08_24		11	8/20/2020 8:27 AM		
SLICE PRO Test	2020_08_11 14_10		11	8/11/2020 2:18 PM		
Add DAS	2020_08_05 14_41		9	8/5/2020 2:46 PM		
SLICE PRO Test	2020_08_04 15_36_ROI Period 1		8	8/4/2020 3:39 PM		
SLICE PRO Test	2020_08_04 15_36_ROI Period 2		8	8/4/2020 3:39 PM		

3. Browse to the desired location (*C:\DTS\DTS.Suite\Data* is the default location for data) and select the DataPRO.dts file from the desired test data folder. Test data is organized by Test Setup name then by the name of the individual dataset:

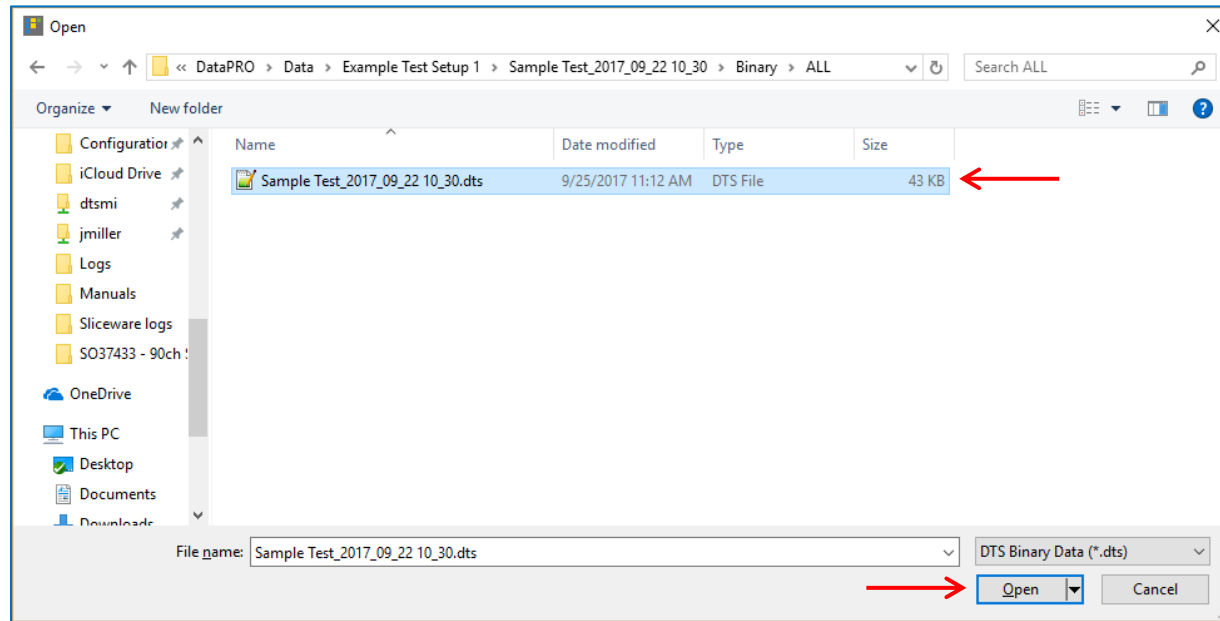

4. To export data from a test listed in the table, double click on the desired test, or highlight and select Export. The table is populated from the DataPRO Data folder. See



5. Appendix E: DataPRO File Structure, page 275:

Test Setup Name	Test ID	Description	Number of Channels	Test Date/Time	Laboratory	Custom
Example Test Setup	2020_01_24 11_17		12	1/24/2020 11:22 AM		
Example Test Setup	2020_01_24 11_17		12	1/24/2020 11:22 AM		
Example Test Setup	2020_01_24 10_41		12	1/24/2020 10:48 AM		
Example Test Setup	2020_01_23 16_38_ROI Period 1		12	1/23/2020 4:47 PM		
Example Test Setup	2020_01_23 16_38_ROI Period 2		2	1/23/2020 4:47 PM		

6. Select the calibration behavior and the data export format(s) and modify fields as needed. All fields in red must be completed:

Export Data

Example Test Setup / 2020_01_24 11_17

Modify fields, if needed, then click on 'Run' button

Export path: D:\DTS\Suite\Data\Example Test Setup\2024_03_22 14_31\Exports

Use non-linear sensitivity, if available

Use linear sensitivity, if available

Use non-linear sensitivity, if available

Use both sensitivities, if available, as separ

TTS

RDF

TDAS

TDMS

DDAS

TSV

HDF

Excel (xlsx)

Chapter 10

ASC

Excel (xlsx) export info

Type: Unfiltered Filtered

Header Items:

Test Date

Test Time

Test ID

Test Description

Sample Rate (Hz)

Hardware AA Filter (-3dB)

ROI period start (sec) -1.000 ROI period end (sec) 1.000

- a. DIAdem: Choose descriptor for line 200 and 201.
- b. CSV: Choose Filtered or Unfiltered, whether to include mV and/or ADC data, and which header items to include.
- c. ISO: See ISO TS13499 RED A for information on export fields.

- o The ISO option has two additional buttons, Export Settings and Import Settings, which can be used to save or load settings to an XML file. When exporting, all settings for all test objects in the current test are written to the file. When importing, all settings are imported but only settings for test objects in the test will be imported and applied.
- d. TTS: Customer specific export format. Choose sub sample intervals.
- e. RDF: Customer specific export format. No export options.
- f. TDAS: Export format compatible with TDAS Control. No export options.
- g. TDMS: Export format compatible with TDAS Manager. No export options.
- h. DDAS: Customer specific export format. No export options.
- i. TSV: Choose Filtered or Unfiltered.
- j. HDF: Choose to include logs, reports, test setup file, ADC data, mV data, EU data.
- k. Excel (xlsx): Choose Filtered or Unfiltered, and which header items to include.
- l. Chapter 10: Choose whether or not to include secondary time headers.
- m. ASC: Customer specific export format.

7. Select Run to export data:

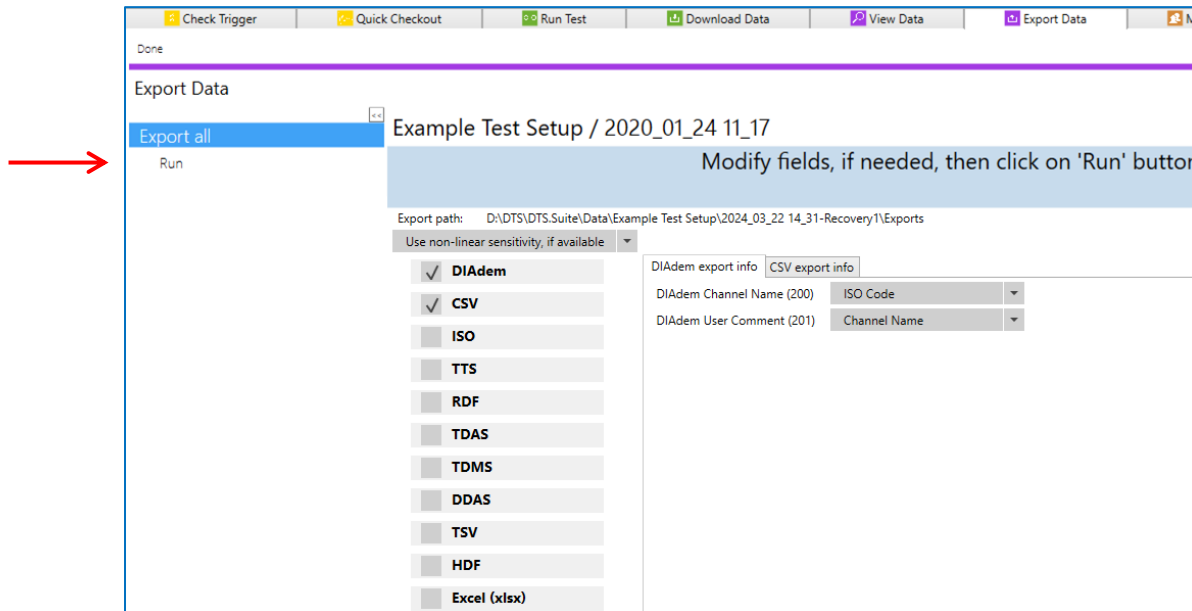

8. The export file(s) will be saved in the original test folder. See

9. [Appendix E: DataPRO File Structure](#), page 275.

10. When finished, select “Done” to return to previous location. To return to the [Quick Start](#) steps, go back to page 32.

Copy & Trim

11. To copy and trim a dataset by start and end time, select the dataset and then select Copy & Trim.

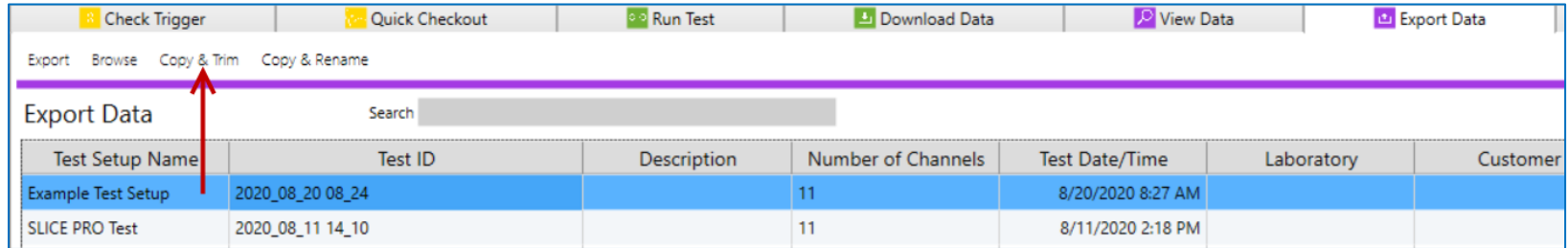

Test Setup Name	Test ID	Description	Number of Channels	Test Date/Time	Laboratory	Customer
Example Test Setup	2020_08_20 08_24		11	8/20/2020 8:27 AM		
SLICE PRO Test	2020_08_11 14_10		11	8/11/2020 2:18 PM		

12. Enter the desired Region of Interest (ROI) period start and end times, and a name for the new dataset. Then click the Copy & Trim button.

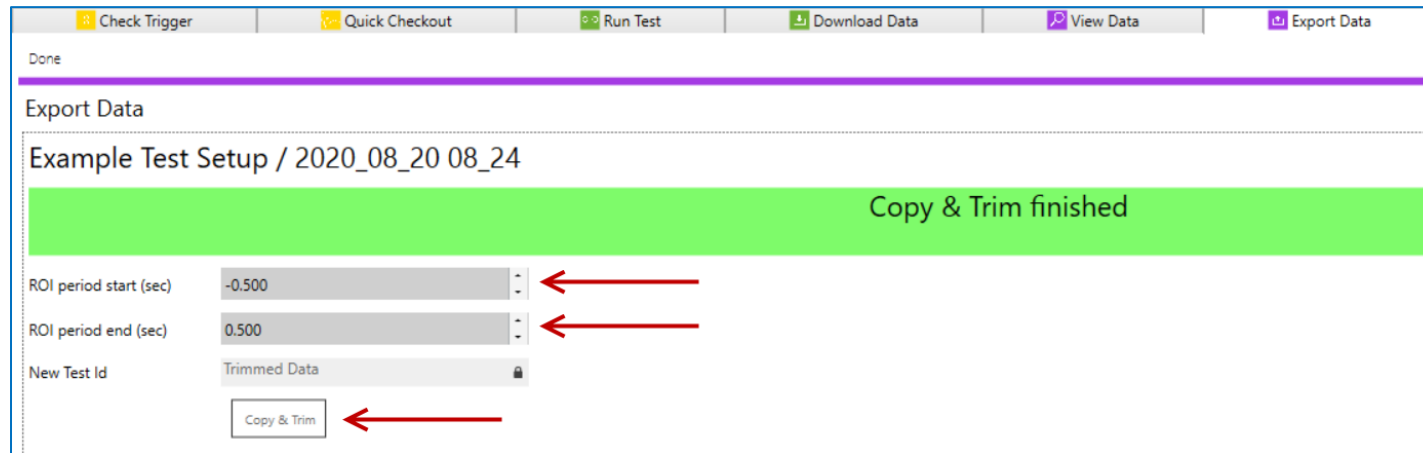

Done

Export Data

Example Test Setup / 2020_08_20 08_24

Copy & Trim finished

ROI period start (sec) -0.500

ROI period end (sec) 0.500

New Test Id Trimmed Data

Copy & Trim

13. The trimmed data will be stored in the Test Setup folder.

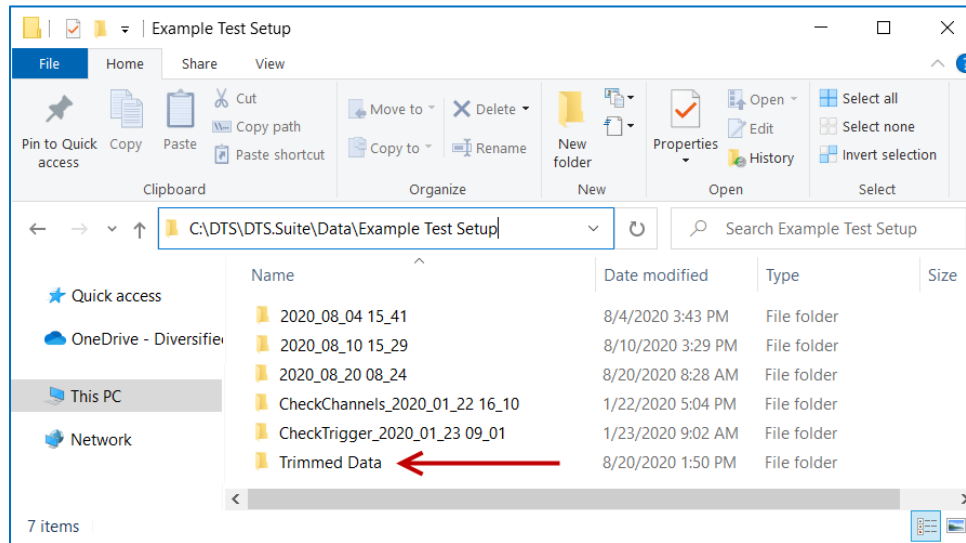

14. To return to the Quick Start steps, go back to page 32.

Copy & Rename

15. To quickly make a copy of an existing dataset, select the dataset and then select Copy & Rename.

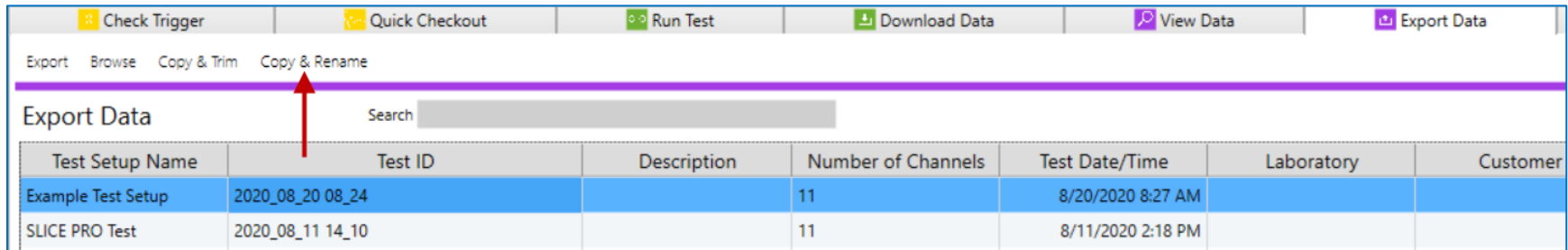

16. Change the Test Name and/or Test Id, then click the Copy & Rename button.

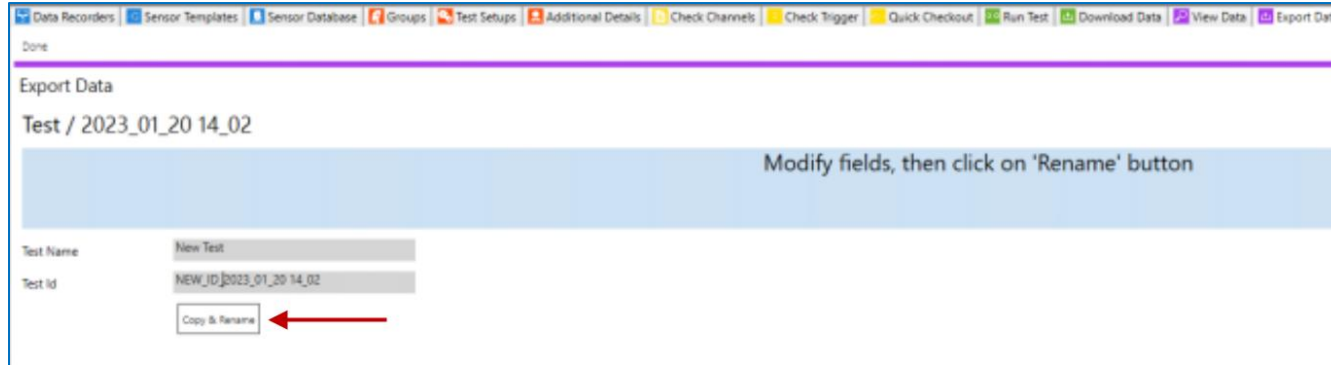

- The changed name and/or id will be used to create a copy of the dataset.
- The Id of the test inside the .dts file will also be updated.

17. To return to the Quick Start steps, go back to page 32.

Administrative

Manage Users

This tab allows the Administrator to add, edit and delete users and user settings. Features and functions available to all DataPRO users are controlled by the Administrator. Contact your Administrator if you need access to features or functions you do not currently have.

REMEMBER:

After initial installation, the Administrator should change the password as soon as possible.

Default Admin password = DTSAAdmin

Four user templates are included and available to use when creating additional users. The templates can be used in the default configuration or modified prior to use.

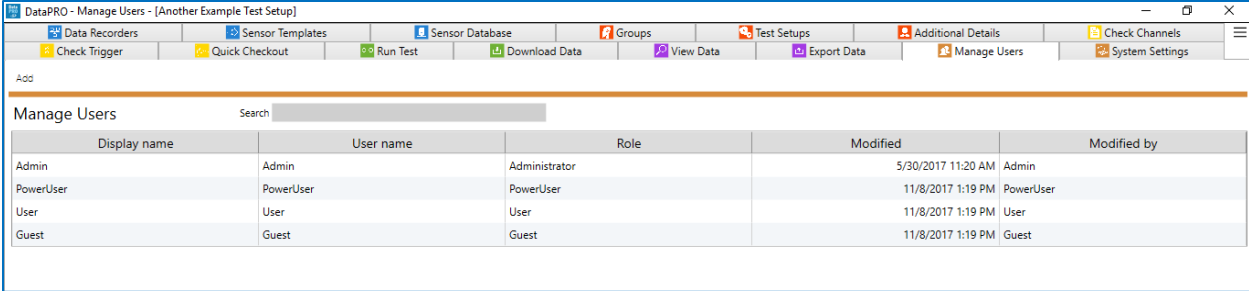

The screenshot shows the 'Manage Users' interface in the DataPRO application. The window title is 'DataPRO - Manage Users - [Another Example Test Setup]'. The interface includes a search bar and a table with the following data:

Display name	User name	Role	Modified	Modified by
Admin	Admin	Administrator	5/30/2017 11:20 AM	Admin
PowerUser	PowerUser	PowerUser	11/8/2017 1:19 PM	PowerUser
User	User	User	11/8/2017 1:19 PM	User
Guest	Guest	Guest	11/8/2017 1:19 PM	Guest

To modify an existing user or edit user templates (Admin, PowerUser, User and Guest), start at step 1. To add a user using existing user templates, go to step 4.

1. To add or edit users, select the “Manage Users” tab:



2. To modify a user, highlight the desired user and then select “Edit”:

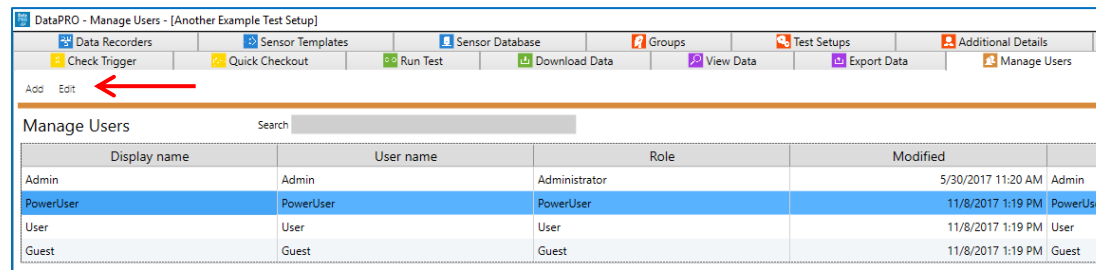

3. Use the navsteps to edit the user “Info”, “Permissions” and “Visibility”:

Default Passwords for New Users	
Admin	<i>DTSAdmin</i>
PowerUser	<i>PowerUser123</i>
User	<i>UserNormal</i>
AeroUser	<i>AeroUser123</i>
CrashUser	<i>CrashUser123</i>
TSRAIRUser	<i>TSRAIRUser123</i>

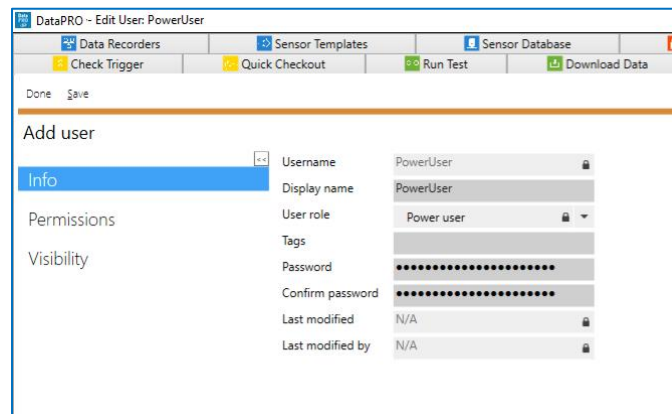

Change the user’s display name.

Use Tags to filter/restrict visibility of Test Setups

Change/confirm the user’s password.

Important: Users should change their passwords as soon as possible.

NOTE: It is recommended to use Visibility to limit user access to features and functions:

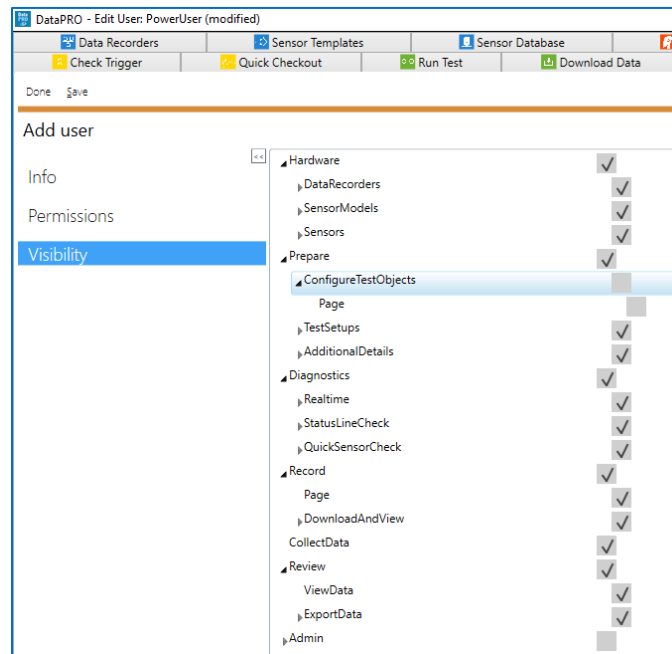

Use arrows to expand menus as necessary

Check to enable a tab

Uncheck to hide a tab

a. Select Save to save changes.

4. To create a new user, select “Add”:

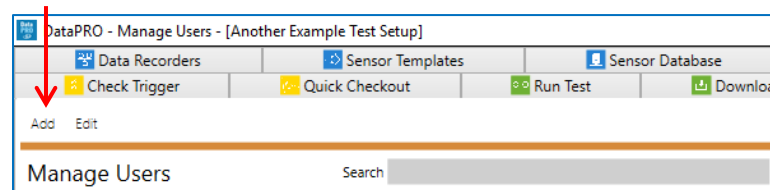

5. Complete the information and select the user template to assign to the user:

- a. Each user template contains default access settings that can be modified when creating new users:
 - i. **Administrator**: Contains access to all tabs with Admin privileges; Edit, Read, and Execute all steps in all tabs.
 - ii. **Power User**: Contains access to all but “Administrative” tabs with Edit privileges.
 - iii. **User**: Contains access to all but “Administrative” tabs with Read and Execute privileges.
 - iv. **Guest**: Contains access to all but “Administrative” tabs with Read privileges.

- b. If the database was initialized with Aero, Crash, or TSR Air settings, a special type of power user is automatically created to streamline functionality and simplify the home screen for these use cases:
 - i. **AeroUser**: User created when the database has been initialized for SLICE 6 AIR streaming and aerospace tests. The AeroUser user does not have access to Sensor Templates, Groups, Additional Details, Check Channels, Check Trigger, and Quick Checkout tabs as these are not typically used in the Aero user workflow.
 - ii. **CrashUser**: User created when the database has been initialized for crash lab use. The CrashUser user can see all non-administrative tabs.
 - iii. **TSRAIRUser**: User created when the database has been initialized for use with TSR AIR devices. The TSRAIRUser user has a similarly paired down home screen as the AeroUser, with just Sensor Database, Test Setups, Run Test, Download Data, View Data, and Export Data.

6. Make any changes to “Permissions” or “Visibility” unique to this user (see step 3) and select “Save” to continue.

7. When finished, select “Done” return to the previous location.

System Settings

Use the System Settings tab to configure various settings such as Test Setup defaults, table layout, ISO, UI, sensor, and power settings:



Test Settings

Configure default settings for new Test Setups, AAF settings, DAS Calibration Intervals, etc.

The screenshot shows the 'System Settings' application window with the 'Test settings' tab selected. The window has a menu bar with options: Check Trigger, Quick Checkout, Run Test, Download Data, View Data, Export Data, Manage Users, and System Settings. Below the menu bar are sub-menus: Restore settings, Import Settings, and Export Settings. The main content area is titled 'System Settings' and features a left-hand navigation pane with categories: Test settings (selected), Test setup settings, Test history settings, Realtime settings, Channel code settings, UI settings, Power settings, Sensor settings, and Advanced settings. The 'Features' section is expanded, showing a list of settings with checkboxes, dropdown menus, and input fields. The settings include: Allow push/pull of sensors (checked), Check trigger quick mode (checked), Allow Quick Build (checked), Automatically start DAS discovery when doing Quick Build (unchecked), Automatically Run Test when doing Quick Build (unchecked), Automatically add arm checklist when adding TOMs (checked), Allow calculated channels (checked), AutoArm diagnostics delay (ms) (30,000), Include Group name in ISO export (checked), Warn if test is cancelled without data export (checked), Control surface port (NONE), Derive ROI from All (unchecked), Trigger check after Real-time (unchecked), Use circular buffer trigger check (checked), Download mode (In parallel), Max parallel TDAS downloads (4), Test ID Prefix/Suffix Values (Run Test,Dry Run,Bench Test), ISO channel/sensor compatibility level (Warn), Warn when a sensor with ID is out of position (unchecked), Allow data collection with a sensor id out of position (checked), Use legacy TDAS Control TOM software filter class setting (unchecked), Use legacy TDAS Control software filter adjustment (unchecked), Allow modification of Test Setup Name and Description (unchecked), Apply "Shift T₀" modifications to Test only (unchecked), Fire TOM digital outputs during diagnostics (checked), Allow push/pull of Group modifications to Test Setups (unchecked), Apply sensor data when assigning channel (checked), Apply hardware channel assignment when discovering sensors (checked), Enable region of interest (ROI) download options (checked), Enable input and output clock source options (checked), Actual Range low limit (%) (100), Actual Range high limit (%) (250), Allowed noise (% FS) (1), Range overhead factor (%) (120), Show Sensor/Channel user values (unchecked), Warn and verify when deleting group channels (unchecked), Allow channel deletion from a fixed group in Test Setup (checked), Use dropdown lists for test object and position (checked), and Create voltage input channels (checked). Two 'Apply setting to all users' buttons are visible next to the 'Apply sensor data when assigning channel' and 'Apply hardware channel assignment when discovering sensors' settings.

1. Features:

- **Allow push/pull of sensors:** If enabled, DataPRO will allow users to push updates made in the Sensor Database to any Groups and Test Setups that include the updated sensor(s). DataPRO will also allow users to pull updates from the Sensor Database to Groups and Test Setups by adding a “Pull sensor parameters” option on these screens.
- **Check trigger quick mode:** If enabled, DAS aren’t armed during check trigger and instead the state of the event and start lines are actively polled. If not enabled, DAS are armed during trigger check as they would be for when data is collected. The default value is enabled.

*NOTE: Level triggers can only be verified if this is **NOT** selected.*

- **Allow Quick Build:** Enables the Quick Build option for test setups, which will quickly build a test setup given DAS which has been used in a test before.
- **Automatically start DAS discovery when doing Quick Build:** If enabled, the Quick Build step will automatically scan for and query all DAS in the database. DAS which respond with configuration information will be added to the Test Setup.
- **Automatically Run Test when doing Quick Build:** If enabled, after discovering DAS which have previously been used in a test the Quick Build will create and run a new Test Setup starting at the Check Sensor ID step.
- **Automatically add arm checklist when adding TOMs:** If enabled, Arm Checklist will automatically be added to any Test Setup that contains TOMs.
- **Allow calculated channels:** If enabled, user can add calculated channels to dataset(s).

NOTE: Channels included in each calculation must be in the same DAS.

- **AutoArm diagnostics delay (ms):** Time to wait after rebooting before running diagnostics when configured to AutoArm.
- **Include Group name in ISO export:** If enabled, Group name will be included in ISO export.
- **Warn if test is cancelled without data export:** If enabled, DataPRO will warn user if Run Test is exited before data download.

NOTE: If not selected, user will be warned of undownloaded data present on hardware during next diagnostic check.

- **Control surface port:** Customer specific setting.

- **Derive ROI from All:** If enabled, the ROI dataset will be automatically generated from the full dataset. If T0 is modified in View Data, the ROI dataset will be automatically regenerated.
- **Trigger check after Real-time:** If enabled, Trigger Check step will happen after Realtime. If not enabled, Trigger Check step will happen before Check Sensor ID.
- **Use circular buffer trigger check:** If enabled, Trigger Check will only test the Event line, regardless of recording mode chosen.
- **Download Mode:** Refers to how the data will be downloaded post-test. Options are *In parallel*, *Parallel by DAS type*, or *Sequentially*.
 - TDAS systems should select either parallel by DAS type or sequentially.
- **Max parallel TDAS downloads:** Maximum number of TDAS systems to download data at the same time.
- **Test ID Prefix/Suffix Values:** Modify or enter additional options to choose as Test ID prefix or suffix.
- **ISO channel/sensor compatibility level:** Options are Don't warn, Warn, Don't allow.
 - Don't warn will allow sensors of any physical dimension to be assigned to any ISO channel without any indication.
 - Warn will indicate physical dimension conflicts but will allow them.
 - Don't allow will require corresponding physical dimension settings in both sensors and ISO channel.
- **Warn when a sensor with ID is out of position:** If enabled, DataPRO will indicate if a sensor's EID is detected on a different hardware channel than what was assigned in Test Setup.
- **Allow data collection with a sensor ID out of position:** If enabled, an out of position sensor EID will not be considered a fault and DataPRO will be able to continue to data collection.
- **Use legacy TDAS Control TOM software filter class setting:** If enabled, TOM channels acquired at greater than 8,000 sps will be filtered at 1650 Hz, while TOM channels acquired at 8,000 sps or less will remain unfiltered.
- **Use legacy TDAS Control software filter adjustment:** If enabled, data will be shifted one sample when filtered to match legacy TDAS Control filter methods.
- **Allow modification of Test Setup Name and Description:** If enabled, modifications to Test Setup Name and Description will be allowed.
- **Apply "Shift T₀" modifications to Test only:** If enabled, T=0 modifications will be applied to test only, option to apply to DAS will not be present.
- **Fire TOM Digital Outputs during Diagnostics:** If enabled, DataPRO will initiate Digital Output signals during diagnostics.
- **Allow push/pull of Group modifications to Test Setup:** If enabled, DataPRO will allow users to push updates made to Groups to any Test Setups that include the updated Group(s). DataPRO will also allow users to pull updates from Group(s) to a Test Setup.

- **Apply sensor data when assigning channel:** If enabled, parameters from the Sensor Database will be applied when adding a sensor to a Group or Test Setup.
- **Apply hardware channel assignment when discovering sensors:** If enabled, applies a hardware channel assignment when discovering sensors.
- **Enable region of interest (ROI) download options:** If enabled, an option to download the ROI will be present in Test Setup.
- **Enable input and output clock source options:** If enabled, an additional menu “Clock sync” will be available in Test Setup to define clock sync options.
- **Actual Range low limit (%):** User configurable value for the Actual Range Low Limit used in Diagnostics.
- **Actual Range high limit (%):** User configurable value for the Actual Range High Limit used in Diagnostics.
- **Allowed Noise (% FS):** Used in diagnostics to determine the boundaries as a percent of full scale for passing or failing the noise check on a sensor.
- **Range overhead factor (%):** User configurable value for the overhead to be added to the sensor max range.
- **Show Sensor/Channel user values:** Will display the “User Value 1, User Value 2 and User Value 3” fields in Parameters navstep of Groups and Test Setups.
 - Values entered will be included in the *.dts export.
- **Warn and verify when deleting group channels:** Enable an additional “Are you sure?” warning to double confirm deletion of channels in a group or test setup.
- **Allow channel deletion from a fixed group in Test Setup:** Enables the Delete button for channels which were added as part of a fixed group in the Test Setup -> Channels navstep. Note that deleting the channel here only removes it from the test setup, not the actual group.
- **Use dropdown lists for test object and position:** If enabled, when configuring groups for a test setup, the text entry fields for Test object and will be changed to dropdown lists prepopulated with commonly used values.
- **Create voltage input channels:** When enabled, dragging an analog hardware channel into a test setup automatically creates a new channel set up as a voltage input channel. If disabled, it simply assigns a hardware channel.

2. Level Triggers:

Level Triggers	
Enable level-trigger UI	<input checked="" type="checkbox"/>
Level Trigger max percentage	0.75
Level Trigger min percentage	0.005

- **Enable level-trigger UI:** If enabled, a sensor can be set up as a level trigger in Test Setup. Note: level triggers are always enabled for TSR AIR tests even when this option is not enabled.
- **Level Trigger min/max percentage:** With respect to the level trigger in realtime, the min and max percentages are relative to whatever the full scale defined for the sensor on the channel is.

3. Communication Timeouts:

Communication timeouts	
Diagnostics timeout TDAS (sec)	480
Diagnostics timeout SLICE (sec)	240
Query download timeout TDAS (sec)	240
Query download timeout SLICE (sec)	120
Query config timeout TDAS (sec)	240
Query config timeout SLICE (sec)	120
Connect timeout TDAS (sec)	90
Connect timeout SLICE (sec)	120

- Specify maximum time to wait for communication responses from hardware.

4. Sample rates and AAF (anti-alias filter) rates:

Sample rates and AAF rates

Import sample rates and AAF settings from TDAS.ini

Valid sample rates
5,50,100,200,250,500,1000,2000,2500,5000,8000,10000,12500,20000,25000,40000,50000,60000,75000,100000,150000,300000,400000,500000

SLICE AAF rates
1@5,10@50,20@100,40@200,50@250,100@500,200@1000,400@2000,500@2500,1000@5000,1600@8000,2900@10000,2900@12500,4000@20000,5000@25000,8000@40000,10000@50000,12000@60000,15000@75000,20000@100000,30000@150000,60000@300000,80000@400000,100000@500000

Max AAF TDAS PRO
4,300

Max AAF G5
3,620

TDAS AAF rates
50@250,100@500,200@1000,500@2000,500@2500,1000@5000,2000@8000,2900@10000,2900@12500,3620@20000,3620@25000,0@40000,0@50000,0@60000,0@75000,0@100000,0@150000,0@300000

Enable editing device AAF rate

- Import existing values from TDAS.ini (available in TDAS Control setup folder, located under C:\DTS\TDAS Control\ by default).
- Default valid sample rates and AAF filtering rates. Each value needs to be separated from another by a comma “,”.
- Add additional sample/filter rates for any hardware type. Each value needs to be written according to the following syntax: *AAF_Value@Sample_Rate*. Separate each value with a comma “,”.
- **Enable editing device AAF rate:** When enabled, displays and allows editing of the AA Filter (Hz) for each data recorder enabled on the Hardware screen of test setups.

5. DAS Calibration intervals (days):

DAS calibration intervals (days)	
TDAS cal interval (days)	365
G5 cal interval (days)	365
SLICE 1.0 cal interval (days)	365
SLICE Base+ cal interval (days)	365
SLICE PRO cal interval (days)	365
PowerPRO cal interval (days)	365
SLICE 6 cal interval (days)	365
SLICE 6 AIR cal interval (days)	365
SLICE 6 Distributor cal interval (days)	365
TSR AIR cal interval (days)	365
Calibration due warning period (days)	30
HW calibration due grace period (days)	30
HW calibration policy	Allow data collection with a grace period on hardware calibration due dates
S6DB RTC expected battery life (days)	1001

- Specify calibration interval for each hardware type.
- Specify 'Calibration Due' warning period.
- Choose hardware calibration due grace period and hardware calibration policy.
- Configure expected RTC battery life for SLICE6 distributors. A warning message will be shown in DataPRO when batteries are near the end of their expected life, or if batteries have lost power or were disconnected and reset.

6. Data Export Options:

Data export options

Add DAS serial number line to CSV export

DIAdem Channel Name (200)

DIAdem User Comment (201)

Export INI file

Use Test Setup for Test ID header in CSV export

Keep ROI and Multiple Events downloads within test folder

Use flat folder structure

Use UTC time in CSV exports

Display UTC time in CSV exports as seconds from 1/1/1970

Use actual range for ISO-MME

Export dual sensitivity sensors in the same file (CSV, XLSX)

Temperature time format

Temperature value format

- **Add DAS serial number line to CSV export:** When enabled, CSV exports will include a line identifying the DAS serial number for each channel. The new field will show up between “Display Name” and “Zero Method”. Disabled by default.
- Specify DIAdem export settings.
- **Export INI file:** Specify where INI file (compatible with TDAS Control) will be saved.
- Select additional options for CSV/XLSX exports, folder structure and ROI downloads.
- **Use UTC time in CSV exports:** Display sample time as the actual UTC time instead of as a delta from t0.
- **Display UTC time in CSV exports as seconds from 1/1/1970:** When using UTC time, display time as an offset in seconds and nanoseconds from 1/1/1970 instead of the actual time. This is also known as “Epoch time” or “Unix time”.

7. Test Setups Import Options:



The screenshot shows a dialog box titled "Test Setups Import Options". It contains two options, each with a checkbox:

- Clear database before TSF import
- Use dynamic groups with CSV import

- **Clear database before TSF import:** Enable this option to erase sensors and objects currently in the database when importing a TSF.
- **Use dynamic groups with CSV import:** Enable this option to create dynamic groups when importing a CSV Test Setup. These groups will only be available for use in the Test Setup created by the import; they will not be stored in the database for use with additional tests.

8. Delete Test Setups:

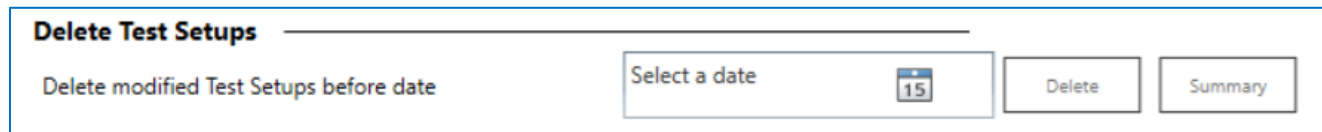

The screenshot shows a dialog box titled "Delete Test Setups". It contains the following elements:

- Text: "Delete modified Test Setups before date"
- Input field: "Select a date" with a calendar icon showing the date "15".
- Buttons: "Delete" and "Summary".

This section allows you to bulk delete older or historical Test Setups based on their last-modified date.

- a. Select a date. All test setups in the database with a Modified Date prior to the selected date will be included.
- b. Select Summary to generate an .xml summary report of the test setups that will be deleted. The report will be stored in Logs\Delete_Multiple and will be named according to the date range selected.
- c. Select Delete to proceed with deleting the selected tests.

Test Setup Settings

Select to configure default settings for new Test Setups. The Admin can configure the default settings for each user. Default settings can be configured for and applied to individual users, or multiple users at one time.

The screenshot displays the 'System Settings' application. The top navigation bar includes buttons for 'Check Trigger', 'Quick Checkout', 'Run Test', 'Download Data', 'View Data', 'Export Data', 'Manage Users', and 'System Settings'. Below this, there are links for 'Restore settings', 'Import Settings', and 'Export Settings'. The main content area is titled 'System Settings' and features a left-hand sidebar with categories: 'Test settings', 'Test setup settings' (highlighted), 'Test history settings', 'Realtime settings', 'Channel code settings', 'UI settings', 'Power settings', 'Sensor settings', and 'Advanced settings'. The central panel shows 'Test setup settings for user: Admin'. A 'TestSetupDefaults' dialog box is open, containing a search field and two sections: '(1) Test info' and '(2) Test Details'. The '(1) Test info' section includes settings such as 'Auto expand info sections', 'Allow advanced recording modes', 'Allow TSR AIR recording modes', 'Allow UART recording modes', 'Recording mode' (set to 'Circular buffer'), 'Number of events to record' (1), 'Default samples per second' (10000), 'Default pre-trigger second(s)' (1), 'Default post-trigger/Test length second(s)' (1), 'Allow streaming modes', 'Set DAS to streaming', 'Set DAS to auto-arm', 'Enable repeat when auto-arm/streaming', 'Preserve run test diagnostics for auto-arm/streaming', 'Download region of interest (ROI)', 'ROI period start second(s)' (-1), 'ROI period end second(s)' (1), 'View ROI', 'Download all', 'View all', 'Warn on missing trigger in Recorder mode', 'Default test setup tag', and 'Interval between event starts, in minutes' (100). The '(2) Test Details' section includes 'Suppress missing sensors warning' and 'Calibration behavior' (set to 'Use non-linear sei'). An 'Apply to:' button is located at the bottom right of the dialog. To the right of the dialog, there is a 'Tags:' input field and a 'Search:' input field. Below these is a table listing users:

Display name	User name	Role	Modified	Modified by
Admin	Admin	Administrator	5/30/2017 11:20:14 AM	Admin
PowerUser	PowerUser	PowerUser	11/8/2017 1:19:48 PM	PowerUser
User	User	User	11/8/2017 1:19:48 PM	User
Guest	Guest	Guest	11/8/2017 1:19:49 PM	Guest
AeroUser	AeroUser	PowerUser	8/2/2022 12:00:00 AM	SYSTEM
CrashUser	CrashUser	PowerUser	8/2/2022 12:00:00 AM	SYSTEM
TSRAIRUser	TSRAIRUser	PowerUser	8/2/2022 12:00:00 AM	SYSTEM

Make changes as needed. All changes are automatically saved to the database for the currently logged in user's profile. To make changes to the default settings for another user, first select that user from the drop down to display their current default settings.

1. Test info:

(1) Test info	
Auto expand info sections	<input type="checkbox"/>
Allow advanced recording modes	<input type="checkbox"/>
Allow TSR AIR recording modes	<input type="checkbox"/>
Allow UART recording modes	<input type="checkbox"/>
Recording mode	Circular buffer ▾
Number of events to record	1
Default samples per second	10000 ▾
Default pre-trigger second(s)	1
Default post-trigger/Test length second(s)	1
Allow streaming modes	<input type="checkbox"/>
Set DAS to streaming	<input type="checkbox"/>
Set DAS to auto-arm	<input type="checkbox"/>
Enable repeat when auto-arm/streaming	<input type="checkbox"/>
Preserve run test diagnostics for auto-arm/streaming	<input type="checkbox"/>
Download region of interest (ROI)	<input checked="" type="checkbox"/>
ROI period start second(s)	-1
ROI period end second(s)	1
View ROI	<input checked="" type="checkbox"/>
Download all	<input checked="" type="checkbox"/>
View all	<input type="checkbox"/>
Warn on missing trigger in Recorder mode	<input checked="" type="checkbox"/>
Default test setup tag	
Interval between event starts, in minutes	1

- **Auto expand info sections:** If enabled, will automatically expand any sections that were previously collapsed on the Test Setups Info screen when creating or editing a test setup.
- **Allow advanced recording modes:** If enabled, adds Hybrid Recorder, Hybrid and Stream, and Continuous Recorder modes to the Recording Mode dropdown in Test Setup (See [Data Collection Concepts](#), page 17, for more information).
- **Allow TSR AIR recording modes:** Enable the Active and Scheduled recording modes used by TSR AIR devices.
- **Allow UART recording modes:** If enabled, options for collecting data in Circular Buffer + UART and Recorder + UART modes will be present.
- **Recording mode:** Default recording mode options are Circular Buffer and Recorder Mode. Optional Hybrid Record mode can be turned on in System Settings (See [Data Collection Concepts](#), page 15, for more information on recording modes. See [System Settings](#), page 210, to enable Advanced Recording Options).

- **Number of events to record:** The number of events to record per test, when using a multiple-event recording mode.
- **Default samples per second:** Choose from options in list. Sample rate chosen must be supported by all DAS in test setup (See [System Settings](#), page 210, to add additional options to list).
- **Default pre-trigger second(s):** The amount of data (in seconds) to be collected pre-trigger. It does not apply to Recorder mode.
- **Default post-trigger/Test length second(s):** The amount of data (in seconds) to be collected post-trigger.
- **Allow streaming modes:** Controls whether streaming modes are available in new test setups.
- **Set DAS to streaming:** If enabled, SLICE6 AIR DAS will be set to streaming by default for new test setups.

NOTE: Set DAS to streaming is only available with SLICE6 AIR DAS.

- **Set DAS to auto-arm:** If enabled, it will set DAS to Auto-Arm by default for new test setups.
- **Enable repeat when auto-arm/streaming:** If enabled, DAS will automatically boot in an armed or streaming state if auto-arm or streaming is enabled. This option will only work with the SLICE6 AIR product.
- **Preserve run test diagnostics for auto-arm/streaming:** If enabled, diagnostic results from Run Test will be preserved and used when DAS is armed for either auto-arm or streaming applications.
- **Download region of interest (ROI):** A period of time, within the full dataset, that contains the dynamic test data. If selected, DataPRO will download a dataset containing only the time window indicated as the ROI.
- **ROI period start (sec):** Defines the amount of time pre-trigger to begin the ROI.
 - Define ROI period Start for each included segment.
- **ROI period end (sec):** Defines the amount of time post-trigger to end the ROI.
 - Define ROI period end for each included segment.
- **View ROI:** If selected, data collection process will include a navstep to view the ROI.
- **Download All:** If selected, DataPRO will download a dataset containing the full dataset defined in Recording Options.
- **View All:** If selected, data collection process will include a navstep to view the full dataset.
- **Warn on missing trigger in Recorder mode:** If selected, DataPRO will warn the user when downloading data that includes units which did not receive any trigger during the data collection event in Recorder mode.
- **Default test setup tag:** Tag to apply to new test setups, by default.
- **Interval between event starts, in minutes:** Number of minutes from the start of one event to the start of the next.

2. Test Details:

▲ (2) Test Details	
Align UDP to PPS	<input type="checkbox"/>
Suppress missing sensors warning	<input checked="" type="checkbox"/>
Calibration behavior	Use non-linear sei ▾
Suppress quit test warning	<input type="checkbox"/>
Realtime: suppress view all channels warning	<input type="checkbox"/>
Viewer: suppress view all channels warning	<input type="checkbox"/>
Common status line	<input checked="" type="checkbox"/>
Check trigger step	<input checked="" type="checkbox"/>
Measure Squib Resistances step	<input type="checkbox"/>
Automatic mode	<input type="checkbox"/>
Automatic mode delay second(s)	0.5
Warn on missing or failed battery	<input type="checkbox"/>
Ignore shorted start	<input type="checkbox"/>
Ignore shorted trigger	<input type="checkbox"/>

- **Align UDP to PPS:** SLICE6 AIR only. Controls the default value for the property Align UDP to PPS in Test Setup. Disabled by default. When enabled, supporting DAS will attempt to align outgoing UDP packets with the 1 PPS time signal.
- **Suppress missing sensors warning:** If selected, DataPRO will allow user to progress without warning if not all sensors are found/channels resolved at Check Sensor ID step.
- **Calibration behavior:** Select to define how test data will be collected for any dual-calibration sensors (sensors which have both a linear and a non-linear definition).
 - Always use linear sensitivity.
 - Use non-linear sensitivity, if available.
 - Use both sensitivities, if available, as separate channels.
- **Suppress quit test warning:** If selected, DataPRO will not warn if user selects “Done” before completing all steps of a data collection event.
- **Real-time: suppress view all channels warning:** If selected, DataPRO will not warn if user does not view Realtime output from all channels in a test setup.
- **Viewer: suppress view all channels warning:** If selected, DataPRO will not warn if user does not review data collected from all channels in a test.
- **Common status line:** Select if all DAS shares same communication path to PC. A typical non-common status line would be a vehicle test that includes a mobile barrier.
- **Check Trigger step:** Select to include a trigger check during data collection event.

- **Measure Squib Resistances step:** Controls whether the squib resistance measurement step is enabled by default for new test setups.
- **Automatic Mode:** Select to automatically progress through data collection sequence. If selected, define an optional delay before DataPRO progresses to the next step.
- **Automatic mode delay second(s):** Optional delay before advancing to next navstep when using Automatic Mode.
- **Warn on missing or failed battery:** If selected, DataPRO will alert user if DAS battery is missing or if measured voltage is outside thresholds set in System Settings (See [Power Settings](#), page 237).
- **Ignore shorted start:** If selected, allows a test to continue without failing if the start signal is detected when Diagnostics is run. A use case for this would be to cause a DAS running in Recorder mode to begin collecting data immediately when armed.
- **Ignore shorted trigger:** If selected, allows a test to continue without failing if the event signal is detected when Diagnostics is run. A use case for this would be to cause a DAS running in Circular Buffer mode to begin collecting data immediately when armed.

3. Diagnostic options:

(3) Diagnostic options	
Require all units pass diagnostics	<input checked="" type="checkbox"/>
Require user confirmation on errors	<input checked="" type="checkbox"/>
Allow missing sensors	<input type="checkbox"/>
Require id found for sensors with ids	<input checked="" type="checkbox"/>
Prepare hardware delay second(s)	6
TOM warmup time (ms)	20000
IEPE warmup time (ms)	30000
Run post-test diagnostics on analog channels	<input type="checkbox"/>
Use tree mode in diagnostics	<input checked="" type="checkbox"/>
Run diagnostics on next step	<input type="checkbox"/>

- **Require all units pass diagnostics:** If selected, DataPRO will not advance beyond the “Realtime” step in Run Test, preventing data collection if any channels fail or if measured DAS voltage is outside thresholds set in System Settings.
- **Require user confirmation on errors:** If selected, DataPRO will require user confirmation in order to progress if any errors are detected.

- **Allow missing sensors:** If selected, DataPRO will allow user to progress if not all sensors are found/channels resolved at Check Sensor ID step.
- **Require id found for sensors:** If selected, DataPRO will require the EID to be detected for any sensor that has an EID listed in the sensor database.
- **Prepare hardware delay seconds:** Optional delay at the start of Diagnostics for sensor/hardware warm up.
- **TOM warmup time (ms):** Optional delay at the start of Diagnostics for TOM hardware to warm up.
- **IEPE warmup time (ms):** Optional delay at the start of Diagnostics for IEPE sensors to warm up.
- **Run post-test diagnostics on analog channels:** If selected, Post-Test Diagnostics will be included as a step in data collection process.
- **Use tree mode in diagnostics:** If selected, diagnostic results will be displayed in Tree mode.
- **Run diagnostics on next step:** If selected, diagnostics will automatically run on landing after preparing the configuration.

4. Realtime options:

(4) Realtime options	
Show realtime	<input checked="" type="checkbox"/>
Number of graphs	6
Chart width second(s)	2
Mask EU meta data	<input type="checkbox"/>
Ethernet SLICE Rate (SPS)	120
SLICE 6 Rate (SPS)	1000
USB SLICE Rate (SPS)	400
TDAS G5 Rate (SPS)	1000
TDAS SIM Rate (SPS)	200

- **Show Realtime:** If selected, Realtime navstep will be included in data collection process.
- **Number of graphs:** Select to display 1, 3, or 6 separate charts at Realtime landing. This can be changed from Realtime navstep.
- **Chart width second(s):** Time interval to be displayed in Realtime. This can also be modified in Realtime navstep.
- **Mask EU meta data:** Masks information related to EU and scaling in TMATs streaming.
- **Ethernet SLICE Rate (SPS):** Realtime sample rate to be used for SLICE hardware with an Ethernet connection.
- **SLICE 6 Rate (SPS):** Realtime sample rate to be used by SLICE6 DAS.
- **USB SLICE Rate (SPS):** Realtime sample rate to be used for SLICE hardware with a USB connection.

- **TDAS G5 Rate (SPS):** Realtime sample rate to be used for TDAS G5 hardware.
- **TDAS SIM Rate (SPS):** Realtime sample rate to be used for TDAS SIM hardware.

5. Arm checklist:

(5) Arm checklist	
Perform arm checklist	<input type="checkbox"/>
Check battery voltage	<input checked="" type="checkbox"/>
Check input voltage	<input checked="" type="checkbox"/>
Require arm checklist when TOM present	<input checked="" type="checkbox"/>
Check squib resistance	<input checked="" type="checkbox"/>
Check sensor ids	<input checked="" type="checkbox"/>
Check start/event line(s)	<input checked="" type="checkbox"/>
Check tilt sensors	<input checked="" type="checkbox"/>
Check temperatures	<input checked="" type="checkbox"/>
Check clock sync	<input checked="" type="checkbox"/>
Require all units pass arm checklist	<input type="checkbox"/>

- **Perform arm checklist:** If enabled, DataPRO will perform Arm Checklist during data collection. Arm checklist test options will only be displayed if Arm Checklist is selected.
- **Check battery voltage:** If enabled, Arm Checklist will include battery voltage measurement. System will fault if measured battery voltage is outside thresholds set in System Settings.
- **Check input voltage:** If enabled, Arm Checklist will include input voltage measurement. System will fault if measured battery voltage is outside thresholds set in System Settings.
- **Require arm checklist when TOM present:** If enabled, Arm Checklist will be automatically added to a Test Setup if a TOM is included in the hardware.
- **Check squib resistance:** If enabled, Arm Checklist will include squib resistance check on TOM channels. System will fault if measured squib resistance is outside threshold set in sensor database.
- **Check sensor ids:** If enabled, Arm Checklist will check sensor IDs. System will fault if expected IDs are not found.
- **Check start/event line(s):** If enabled, Arm Checklist will include check of start/event status lines. System will fault if DataPRO detects a short on either.
- **Check tilt sensor(s):** If enabled, Arm Checklist will include check of SLICE6 tilt sensor(s). Measured values will only be displayed.
- **Check temperature:** If enabled, Arm Checklist will include check of SLICE6 temperature. Measured values will only be displayed.
- **Check clock sync:** If enabled, Arm Checklist will include a check of the Clock Sync.
- **Require all units pass arm checklist:** If enabled, DataPRO will not progress to Arm System if any faults are detected in any tests included in Arm Checklist.

6. Export options:

(6) Export options	
Export data	<input type="checkbox"/>
CSV unfiltered EU	<input type="checkbox"/>
CSV filtered EU	<input type="checkbox"/>
CSV unfiltered mV	<input type="checkbox"/>
CSV unfiltered ADC	<input type="checkbox"/>
DIAdem ADC	<input type="checkbox"/>
ISO unfiltered EU	<input type="checkbox"/>
ISO filtered EU	<input type="checkbox"/>
TDAS ADC	<input type="checkbox"/>
TTS unfiltered EU	<input type="checkbox"/>
TSV unfiltered EU	<input type="checkbox"/>
TSV filtered EU	<input type="checkbox"/>
RDF ADC	<input type="checkbox"/>
TDMS ADC	<input type="checkbox"/>
DDAS unfiltered EU	<input type="checkbox"/>
HDF unfiltered EU	<input type="checkbox"/>
HDF mV	<input type="checkbox"/>
HDF ADC	<input type="checkbox"/>
XLSX unfiltered EU	<input type="checkbox"/>
XLSX filtered EU	<input type="checkbox"/>
Export ASC	<input type="checkbox"/>

- **Export data:** If enabled, DataPRO will export a data set in each of the selected format(s). Raw data is always downloaded.
- **CSV unfiltered EU/filtered EU/unfiltered mV/unfiltered ADC:** Select desired data types to be exported in one Comma Separated Variable file.
- **DIAdem ADC:** Data format comprised of one .dat header file for the test and one binary file for each channel in the test.
- **ISO unfiltered EU/filtered EU:** Data format that follows the ISO-TS 13499 requirements.
- **TDAS ADC:** Data format compatible with TDAS Control.
- **TTS unfiltered EU:** Customer specific data format.
- **TSV unfiltered EU/filtered EU:** All test data is contained in one Tab Separated Value file.

- **RDF ADC:** Customer specific data format.
- **TDMS ADC:** Data format that follows the TDM Streaming file format.
- **DDAS filtered EU:** Customer specific data format.
- **HDF unfiltered EU/mV/ADC:** Hierarchical Data Format; designed to store and organize large amounts of data.
- **XLSX unfiltered EU/filtered EU:** Data format compatible with Microsoft Excel.
- **Export ASC:** Customer specific data format.

7. Upload Options:

(7) Upload options	
Upload data	<input checked="" type="checkbox"/>
Upload folder	<input type="checkbox"/>
Upload Export file(s) only	<input type="checkbox"/>

- **Upload data:** If enabled, collected data will be uploaded to a specified location during the data collection process. Data will still be downloaded to the default location of *C:\DTS\DTS.Suite\Data*, or other location as defined in the configuration file.
- **Upload folder:** File location for collected data to be stored/uploaded during data collection process.
- **Upload Export file(s) only:** If enabled, only the data export files will be uploaded to the designated location.

8. Clock sync options:

(8) Clock sync options	
Clock master default profile	None ▼
Clock slave default profile	None ▼

These settings define the default clock sync behavior for supported hardware in new test setups. Changing these options will not affect any existing tests. Note that “Enable input and output clock source options” must be enabled in System Settings ->Test Settings in order for the clock sync options to be visible on the Test Setup -> Info navstep.

- **Clock master default profile:** Select the default Clock Master profile for new test setups. Make sure to choose the proper In AND Out clock types for the Master default.
- **Clock slave default profile:** Select the default Clock Slave profile for new test setups.

Test History Settings

Specify default behavior for settings related to the test history.

NOTE: The test history can be viewed in sensor database usage reports, or when selecting a test setup when one or more of these settings is enabled.

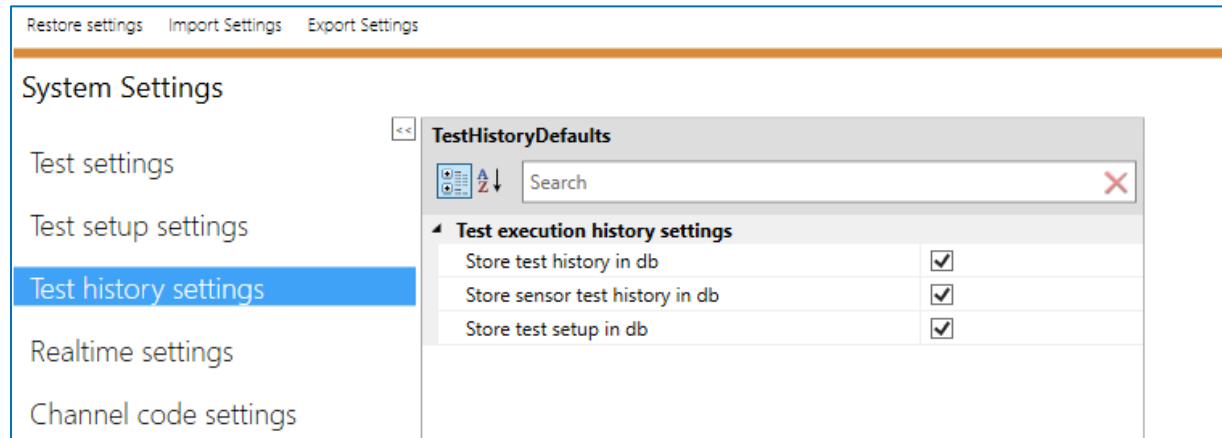

1. Test execution history settings:

- **Store test history in db:** If enabled, will store the test execution history in the DataPRO database. Selecting this option will enable the following two configuration options:
 - **Store sensor test history in db:** If enabled, will store the sensor information in the database when the test is run.
 - **Store test setup in db:** If enabled, will store the test setup information in the database when the test is run.

Realtime Settings

View/change default Realtime settings:

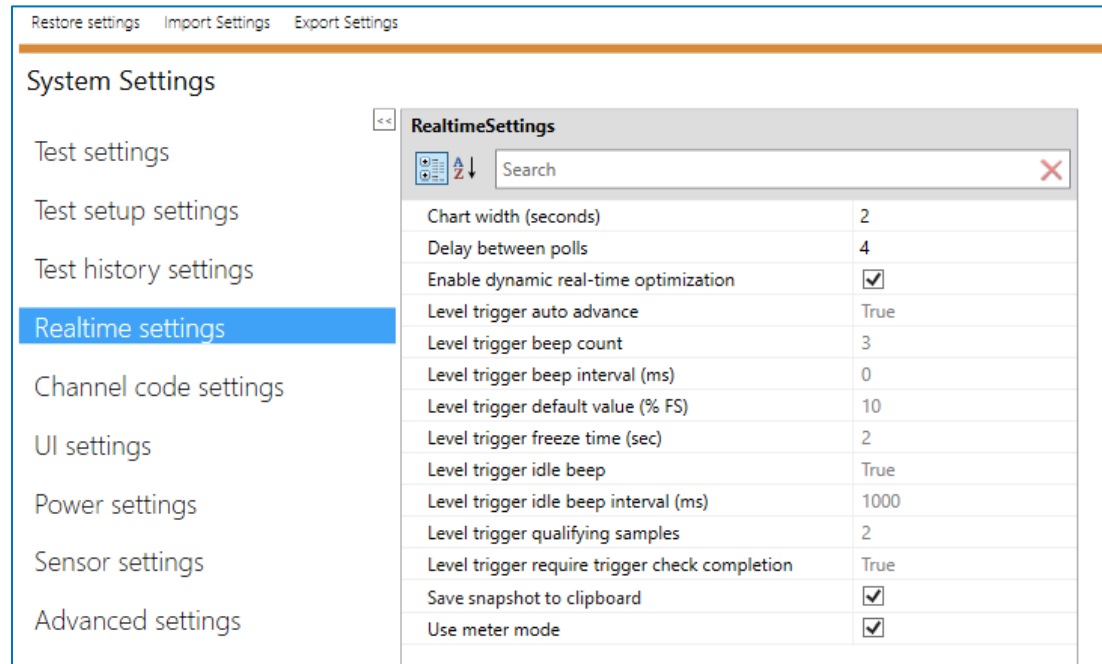

The screenshot shows a software interface with a sidebar on the left containing the following menu items: System Settings, Test settings, Test setup settings, Test history settings, Realtime settings (highlighted), Channel code settings, UI settings, Power settings, Sensor settings, and Advanced settings. At the top of the main window are buttons for 'Restore settings', 'Import Settings', and 'Export Settings'. The 'RealtimeSettings' dialog box is open, displaying a search bar and a table of settings:

Setting Name	Value
Chart width (seconds)	2
Delay between polls	4
Enable dynamic real-time optimization	<input checked="" type="checkbox"/>
Level trigger auto advance	True
Level trigger beep count	3
Level trigger beep interval (ms)	0
Level trigger default value (% FS)	10
Level trigger freeze time (sec)	2
Level trigger idle beep	True
Level trigger idle beep interval (ms)	1000
Level trigger qualifying samples	2
Level trigger require trigger check completion	True
Save snapshot to clipboard	<input checked="" type="checkbox"/>
Use meter mode	<input checked="" type="checkbox"/>

- **Chart width:** Period of time to display in Realtime view panel (Also adjustable in Realtime navstep).
- **Delay between polls:** Time, in ms, between calls to DAS for Realtime data.

NOTE: Realtime Data will be streaming from SLICE hardware, rather than polling, if the installed firmware supports this feature. (See table below).

Hardware Type	Firmware Required
SLICE Base 1.0	Not supported
SLICE Base+	B1F8
SLICE PRO SIM	A1N1
SLICE6	F0L7

NOTE: Realtime AAF ratio is 1:1 by default. This setting can be changed in the DataPRO.exe.config file. See the DataPRO Settings Manual for more information about the config file.

- **Enable dynamic real-time optimization:** If True, DataPRO will dynamically adjust sampling rates in the realtime viewer based on tested download speeds. Only models defined in RealtimeOptimizationSettings.xml will be affected.
- **Level trigger auto advance:** If True, channel will automatically advance once Realtime level trigger threshold has been met. Level triggers on must be enabled in order to modify.
- **Level trigger beep count:** Number of audible beeps once Realtime level trigger threshold has been met. Level triggers on must be enabled in order to modify.
- **Level trigger beep interval (ms):** Interval for audible beeps indicating Realtime level trigger threshold has been met. Level triggers on must be enabled in order to modify.
- **Level trigger default value (%FS):** Default value for Realtime level trigger threshold. Level triggers on must be enabled in order to modify.
- **Level trigger freeze time (sec):** Amount of time for Realtime display to freeze once Realtime level trigger threshold has been met. Level triggers on must be enabled in order to modify.
- **Level trigger idle beep:** If True, an audible beep will be heard at the interval specified in “Level trigger idle beep interval” when Realtime signal is not within the Realtime level trigger bounds. Level triggers on must be enabled in order to modify.
- **Level trigger idle beep interval (ms):** Interval for audible beeps indicating Realtime level trigger threshold is not within Realtime level trigger bounds. Level triggers on must be enabled in order to modify.
- **Level trigger qualifying samples:** Number of consecutive samples within Realtime level trigger bounds required

to validate Realtime level trigger. Level triggers on must be enabled in order to modify.

- **Level trigger require trigger check completion:** If True, DataPRO will require that all channels included in Test Setup complete the Realtime level trigger check. Level triggers on must be enabled in order to modify.
- **Save snapshot to clipboard:** If enabled, snapshots taken from the Realtime screen will be copied to the clipboard instead of saved as a CSV.
- **Use meter mode:** If enabled, Meter Mode will be available as a display option during Realtime.

Channel Code Settings

Choose channel code settings for use in Sensor Database, Group and Test Setup tabs:

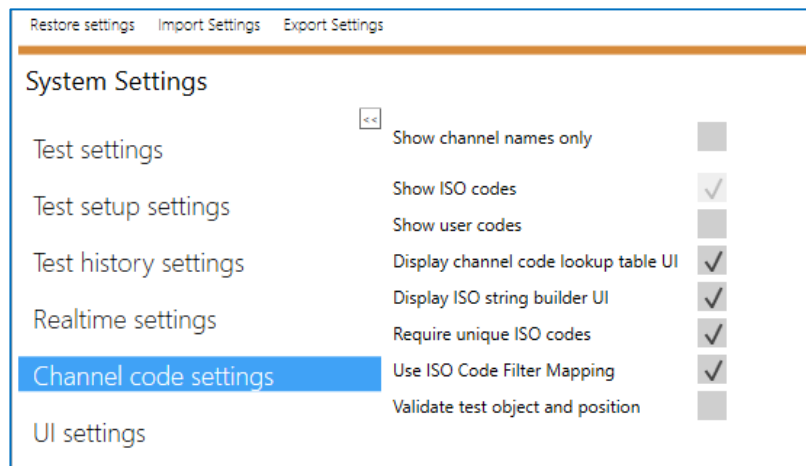

DataPRO allows for the use of three different channel identifiers: Channel Names, ISO Codes and User Codes. If no ISO or User codes are used, select “Show channel names only”.

If “Show channel names only” is selected, all other options are disabled.

If “Show ISO codes” is selected, the following options are enabled:

- **Display channel code lookup table UI:** If selected, a table listing all available Channel Codes will be displayed to assist in code selection.
- **Display ISO string builder UI:** If selected, a table identifying each ISO Code parameter will be displayed to assist in creating ISO Codes.
- **Require unique ISO codes:** If selected, each channel in a Test Setup must have a unique ISO Code in order to be considered a valid test setup.
- **Use ISO Code Filter Mapping:** If selected, the ISO Code must match the sensor filter setting. Changing one of these options will change the other to match.
- **Validate test object and position:** When saving/editing a test setup, warn if the test object or position (first two digits of the channel ISO code) are invalid.

If only “Show user codes” is selected, only the **Display channel code lookup table UI** option is available.

UI Settings

The user interface settings include various display and formatting options:

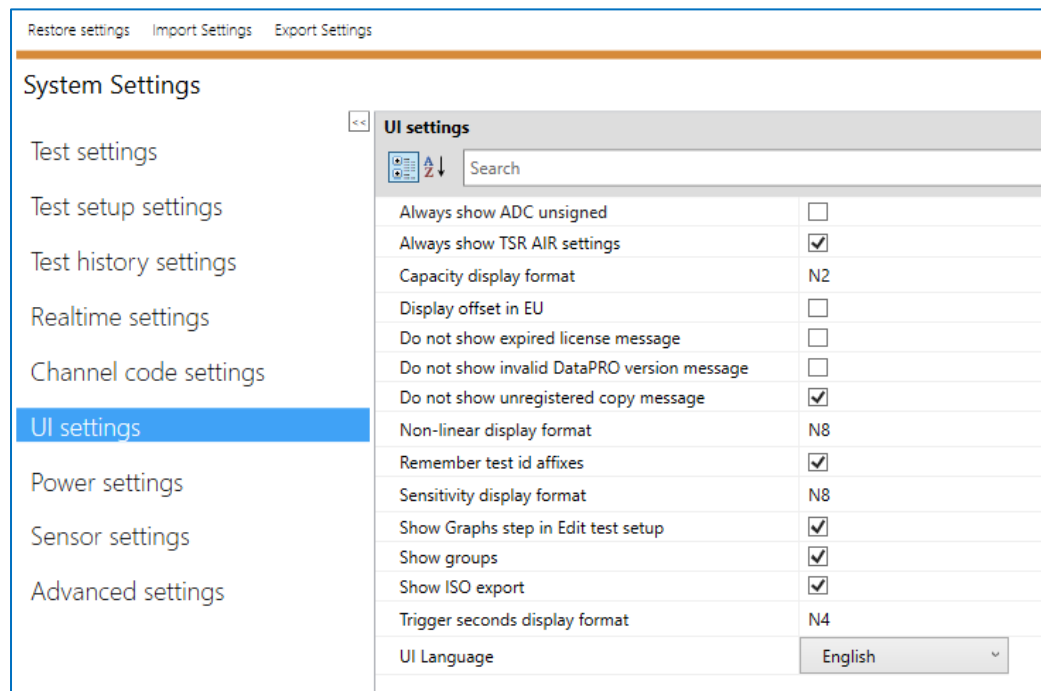

- **Always show ADC unsigned:** Enabling this option will display analog data counts in the DataPRO user interface as 16-bit unsigned data. It does not affect the underlying data or any exported, recorded, or streamed data.
- **Always show TSR AIR settings:** Controls whether TSR AIR settings should always be shown in Edit Test Setup.
- **Display offset in EU:** Display offset in EU rather than mV.
- **Do not show expired license message:** Suppress the warning message for expired DataPRO licenses.
- **Do not show invalid DataPRO version message:** Suppress the warning message for invalid versions of DataPRO.
- **Do not show unregistered copy message:** Suppress the warning message for unregistered copies of DataPRO.
- **Remember test id affixes:** Remember the last values chosen for the test id prefix and suffix on the Run Test tab.
- **Show Graphs setup in Edit test setup:** Controls whether the Graphs navstep is shown in Edit Test Setup.
- **Show groups:** Controls whether the Groups tab is visible, and whether groups are shown in Edit Test Setup and other areas.

- **Show ISO export:** Controls whether ISO 13499 export options are shown in Export and Test Setup.
- **UI Language:** Change the language for the DataPRO user interface (requires restarting DataPRO). Supported languages include German, English, Spanish, French, Italian, and Japanese.
- **Configurable formats** include the **capacity display format**, **non-linear display format**, **sensitivity display format**, and **trigger seconds display format**. These formats use standard numeric format strings and can be specified as follows:

Description	Format and Precision Specifier	Example
Number: Integers and decimals, group and decimal separators, with optional negative sign	N or n <i>Number of decimal places</i>	N where 1234.567 = 1,234.57 N1 where 1234 = 1,234.0 N3 where -1234.56 = -1,234.560
Decimal: Integers with optional negative sign	D or d <i>Minimum number of digits</i>	D where 1234 = 1234 D6 where -1234 = -001234
Exponential (scientific): Exponential notation	E or e <i>Number of decimal digits</i>	E where 1052.0329 = 1.052033E+003 E2 where -1052.0329 = -1.05e+003
Fixed-point: Integers and decimals with optional negative sign	F or f <i>Number of decimal digits</i>	F where 1234.567 = 1234.57 F4 where -1234.56 = -1234.5600

For more information, see <https://docs.microsoft.com/en-us/dotnet/standard/base-types/standard-numeric-format-strings>.

Power Settings

Specify thresholds for input power/battery warnings:

System Settings									
Settings									
Test settings	TDAS PRO Rack	Input							
		Diagnostics (low)	Diagnostics (med)	Diagnostics (high)	Armed (low)	Armed (med)	Armed (high)	Min valid	Max valid
Test setup settings	TDAS PRO Rack	11.50	12.50	13.20	11.50	12.50	13.20	4.00	16.00
		Battery							
Test history settings	TDAS PRO Rack	Diagnostics (low)	Diagnostics (med)	Diagnostics (high)	Armed (low)	Armed (med)	Armed (high)	Min valid	Max valid
		11.50	12.50	13.20	11.50	12.50	13.20	4.00	16.00
Realtime settings	G5 (VDS)	Input							
		Diagnostics (low)	Diagnostics (med)	Diagnostics (high)	Armed (low)	Armed (med)	Armed (high)	Min valid	Max valid
Channel code settings	G5 (VDS)	10.90	11.30	13.20	10.90	11.30	13.20	4.00	16.00
		Battery							
UI settings	G5 (VDS)	Diagnostics (low)	Diagnostics (med)	Diagnostics (high)	Armed (low)	Armed (med)	Armed (high)	Min valid	Max valid
		10.90	11.30	13.20	10.90	11.30	13.20	4.00	16.00
Sensor settings	G5 (In-dummy)	Input							
		Diagnostics (low)	Diagnostics (med)	Diagnostics (high)	Armed (low)	Armed (med)	Armed (high)	Min valid	Max valid
Advanced settings	G5 (In-dummy)	11.00	11.50	15.00	11.00	11.50	15.00	4.00	16.00
		Battery							
	G5 (In-dummy)	Diagnostics (low)	Diagnostics (med)	Diagnostics (high)	Armed (low)	Armed (med)	Armed (high)	Min valid	Max valid
		11.00	11.50	15.00	11.00	11.50	15.00	4.00	16.00
	SLICE Distributor	Input							
		Diagnostics (low)	Diagnostics (med)	Diagnostics (high)	Armed (low)	Armed (med)	Armed (high)	Min valid	Max valid
	SLICE Distributor	10.00	12.70	15.30	6.50	10.90	15.30	4.00	19.00
		Battery							
	SLICE Distributor	Diagnostics (low)	Diagnostics (med)	Diagnostics (high)	Armed (low)	Armed (med)	Armed (high)	Min valid	Max valid
		7.80	8.40	9.00	6.80	7.90	9.00	4.00	9.00
		Input							
		Diagnostics (low)	Diagnostics (med)	Diagnostics (high)	Armed (low)	Armed (med)	Armed (high)	Min valid	Max valid

Sensor Settings

Specify the default settings for new sensor database entries of various sensor types:

Category	Setting	Value
Squib defaults	Delay (ms)	0.00
	Limit duration	✓
	Duration (ms)	10.0
	Low tolerance (Ω)	0.9
	High tolerance (Ω)	8.0
	Firing mode	Capacitor discharge
Digital output defaults	Output mode	5V low to high transition
	Delay (ms)	0.00
Digital input defaults	Limit duration	✓
	Duration (ms)	10.00
IEPE defaults	Constant current breakpoint (ADC)	19,005.00
	Voltage input breakpoint (ADC)	19,661.00
	Display SPD analog data	<input type="checkbox"/>
	24V Power low (V)	23.0
	24V Power high (V)	26.5

1. Squib defaults:

Setting	Value
Delay (ms)	0.00
Limit duration	✓
Duration (ms)	10.0
Low tolerance (Ω)	0.9
High tolerance (Ω)	8.0
Firing mode	Capacitor discharge

- See [Sensor Templates](#), page 46, and [Sensor Database](#), page 52, for more information on these options.

2. Digital output defaults:

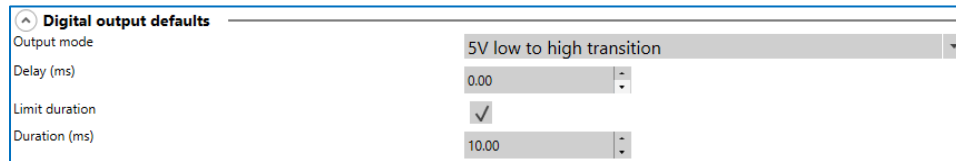

The screenshot shows a configuration panel titled "Digital output defaults". It contains the following settings:

Parameter	Value
Output mode	5V low to high transition
Delay (ms)	0.00
Limit duration	<input checked="" type="checkbox"/>
Duration (ms)	10.00

- See [Sensor Templates](#), page 46, and [Sensor Database](#), page 52, for more information on these options.

3. Digital input defaults:

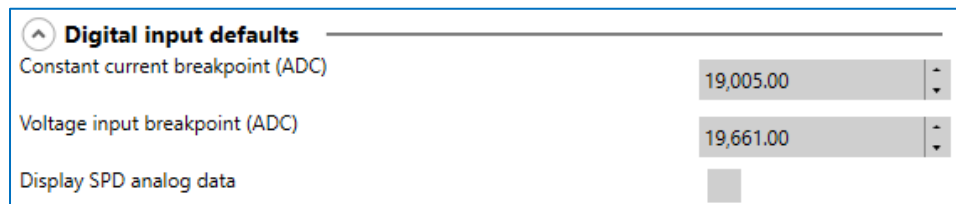

The screenshot shows a configuration panel titled "Digital input defaults". It contains the following settings:

Parameter	Value
Constant current breakpoint (ADC)	19,005.00
Voltage input breakpoint (ADC)	19,661.00
Display SPD analog data	<input type="checkbox"/>

- See [Sensor Templates](#), page 46, and [Sensor Database](#), page 52, for more information on these options.

4. IEPE defaults:

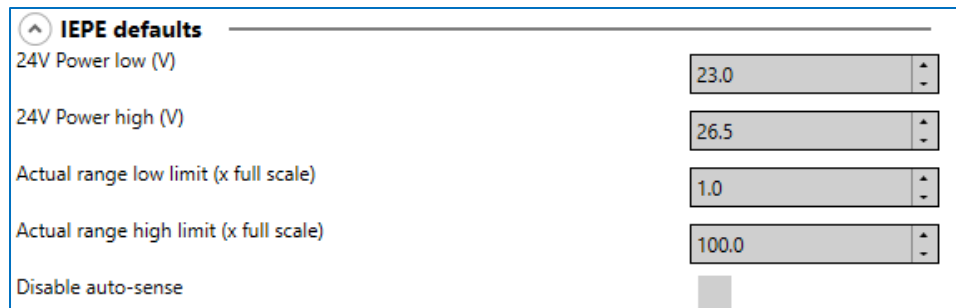

The screenshot shows a configuration panel titled "IEPE defaults". It contains the following settings:

Parameter	Value
24V Power low (V)	23.0
24V Power high (V)	26.5
Actual range low limit (x full scale)	1.0
Actual range high limit (x full scale)	100.0
Disable auto-sense	<input type="checkbox"/>

- Select default low/high power and low/high range limits for IEPE sensors.
- **Disable auto-sense:** If checked, Auto-Sense will not be run to detect IEPE sensors and will instead rely on test configuration.

5. Sensor calibration policies:

The screenshot shows a configuration panel titled "Sensor calibration policies" with several settings:

- Calibration interval starts after sensor's first use:**
- Policy:** Do not allow data collection with overdue sensor calibration (dropdown menu)
- Warning period (days):** 14 (dropdown menu)
- Do not allow data collection if sensor is overused:**
- Warn when number of uses remaining:** 5 (input field)
- Default maximum uses allowed:** 2500 (input field)
- Inspect before use:**

- **Calibration interval starts after sensor's first use:** Enable to begin the calibration interval after a sensor has been used for the first time. This may be useful in cases where the calibration interval should not begin until the sensor has been used in a destructive test.
- **Policy:** Controls whether or not data can be collected using sensors that are past due for calibration.
- **Warning period (days):** The number of days before the calibration due date that DataPRO should alert the user of the upcoming calibration deadline. Sensors that are used within this warning period will be shaded orange.
- **Do not allow data collection if sensor is overused:** Controls whether or not data can be collected using sensors that have a Usage Count greater than the sensor's Maximum Usage value. Checking this box causes the Warn when number of uses remaining and Default maximum uses allowed fields to appear underneath.
- **Warn when number of uses remaining:** This value determines when to display a warning message that a sensor is getting close to its Maximum Usage.
- **Default maximum uses allowed:** The default number of times a sensor is allowed to be used before being prevented from use. This value is assigned to a sensor when the sensor is created, and can be changed on a per-sensor basis.
- **Inspect before use:** Checking this enables the Inspect before use checkbox and Sensitivity change tolerance (%) field in the sensor configuration. These fields can be used to track whether the sensor requires inspection due to a deviation in sensitivity value.

6. Analog defaults:

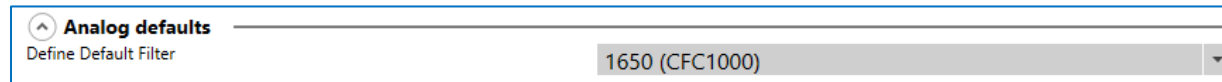

^ Analog defaults
Define Default Filter 1650 (CFC1000)

- **Define Default Filter:** Select the default software filter for new sensors.

7. UART defaults:

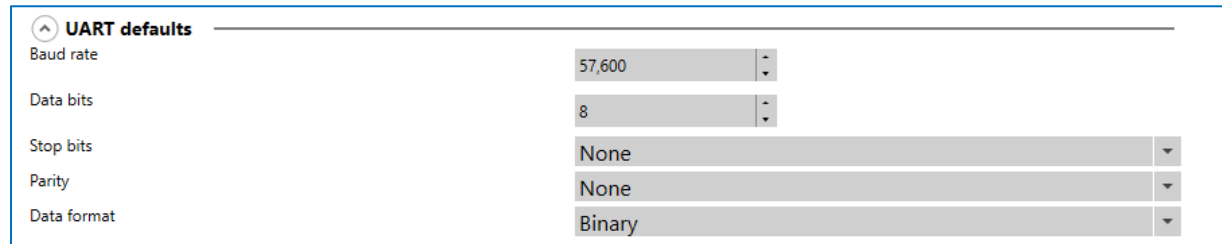

^ UART defaults

Baud rate	57,600
Data bits	8
Stop bits	None
Parity	None
Data format	Binary

- **Baud rate:** Rate that information is transferred, in bits per second.
- **Data bits:** Number of bits used to represent device commands, readings, or error messages. Note: Most serial ports use between 5 and 8 data bits. Binary data is typically transmitted as 8 bits.
- **Stop bits:** Number of bits used to indicate the end of a byte (1, 1.5, or 2).
- **Parity:** Parity bit setting used to determine transmission errors (None, Odd, Even, Mark, or Space).
- **Data format:** The format in which data should be stored (Binary, Text, or National Marine Electronics Association [NMEA]).

8. Stream output defaults:

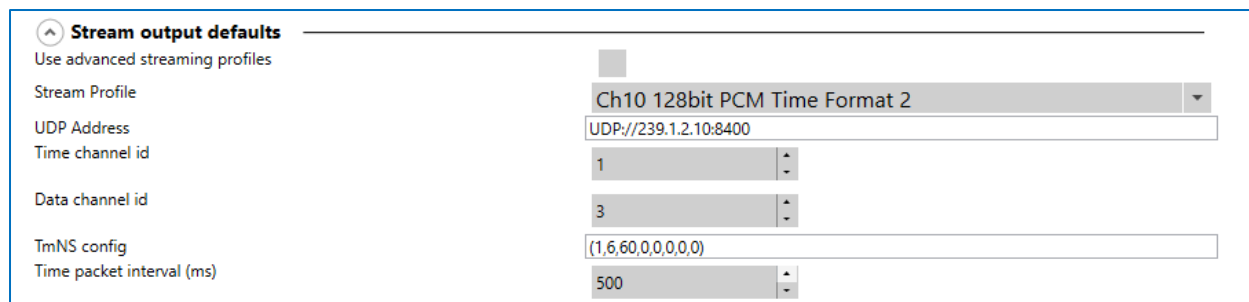

^ Stream output defaults

Use advanced streaming profiles

Stream Profile	Ch10 128bit PCM Time Format 2
UDP Address	UDP://239.1.2.10:8400
Time channel id	1
Data channel id	3
TmNS config	(1,6,60,0,0,0,0,0)
Time packet interval (ms)	500

- **Stream profile:** Data format for streaming realtime data over UDP. Additional fields will be configurable based on the selected format.
 - Ch10 Analog Time Format 2
 - Ch10 128bit PCM Time Format 2
- **Use advanced streaming profiles:** Checking this box adds some less commonly used data formats to the stream profile selection dropdown, which can then be selected if needed.
 - Ch10 Analog
 - Ch10 128bit PCM
 - TmNS 144bit PCM
 - TmNS Supercom (4xADCscan) PCM
 - IENA Positional Message Format
 - DTS Reserved
 - ADC-to-UART stream
- **UDP address:** Address to which UDP packets will be streamed to. This can be a broadcast address or an IPv4 address.
- **Time channel id:** Numeric id of a time channel for streaming profiles that contain a time channel (CH10).
- **Data channel id:** Numeric id of a data channel for streaming profiles that contain a data channel (CH10).
- **TmNS config:** Additional configuration options for TmNS. Values are Packet ID, TmNS Message ID, and read only 60 minor frame/major frames. Contact DTS for more information and help.
- **IRIG time packet interval (ms):** Amount of time between time data packets.
- **Subframe Id:** Package id sent over in stream packets.
- **Message Id:** Message id sent over in stream packets.
- **Minor per major:** Number of minor frames per major frame in packets (default 60).
- **TMATS port:** Allows sending TMATS on a separate port (can be same port). Only used in TMNS; CH10 modes always send on the same port.
- **TMATS interval:** Interval between sending TMATS information, for streaming modes which support it. Set to 0 to disable (default 1000ms).
- **Source port:** IENA source port device will stream from.
- **IENA key:** Key id in IENA packets.

Advanced Settings

Configure advanced system settings.

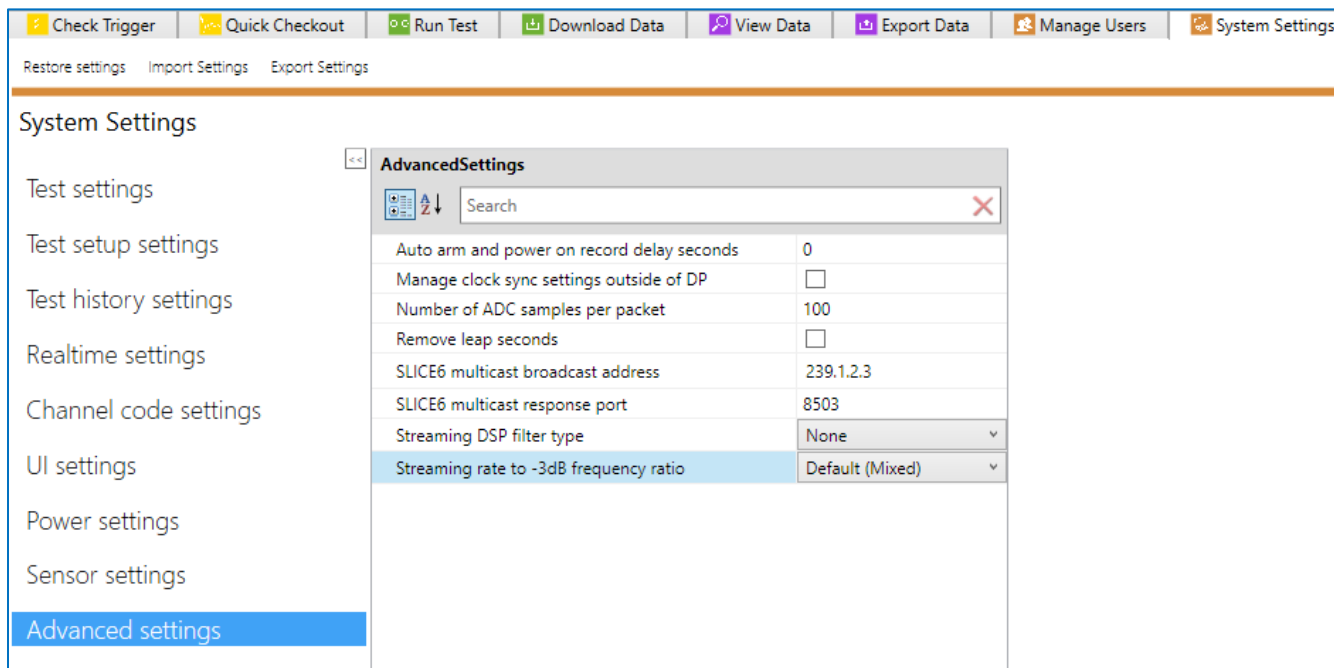

- **Auto arm and power on record delay seconds:** Amount of time to delay before arming for devices that support delaying before arming when using record on boot mode. Defaults to 0.
- **Manage clock sync settings outside of DP:** Use this setting if clocks are to be managed outside of DataPRO. If enabled, the clock sync options will be unavailable inside of Test Setup.
- **Number of ADC samples per packet:** Number of samples sent per data packet, per second, for SLICE6AIR streaming with firmware G0N8 and later. The firmware caps at a maximum of 1400 and will limit packets to 2ms to avoid clogging the network.
- **Remove leap seconds:** Controls whether leap seconds are removed from streaming timestamps or not. Firmware G0N7 or greater is required for this feature.
- **SLICE6 multicast broadcast address:** Specify the IP address used to broadcast data.
- **SLICE6 multicast response port:** Specify the port used to receive responses from the DAS.

- **Streaming DSP filter type:** Apply an optional digital signal processing filter when streaming, for DAS which support it. Available options include:
 - None (Default—no additional filtering is applied to streaming data.)
 - 6th IIR Butterworth
 - 45-Tap FIR
- **Streaming rate to -3dB frequency ratio:** Additional configuration of the digital filter when using 6th IIR Butterworth as the filter. This lets the filter be variable based on the sample rate. Note: Hardware may have lower and upper bounds on the digital filter rates that are possible. Available options include:
 - Default (Mixed)
 - Sample rate / 4
 - Sample rate / 6.4
 - Sample rate / 8
 - Sample rate / 10

Database

This navstep is only enabled when DataPRO is configured to operate with both a local database and a SQL server database.

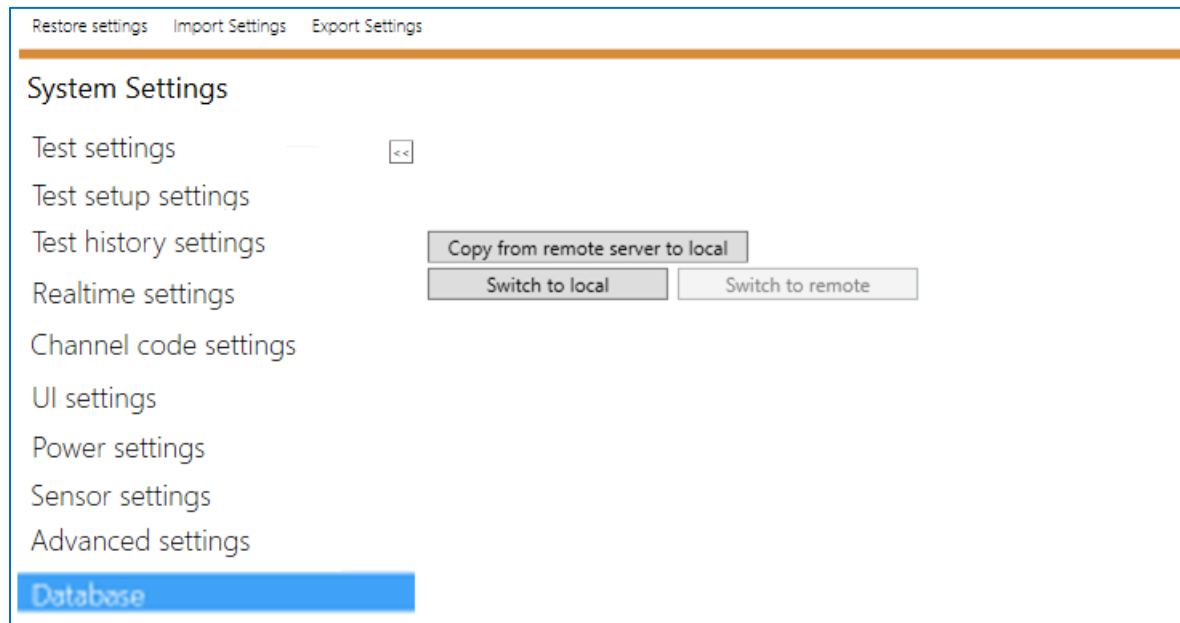

- When configured to connect to the local database, DataPRO will give the option to “Switch to remote”:
- When configured to connect to a remote/SQL database, DataPRO will give the option to “Switch to local”:
- Select “Copy from remote to local” to make a copy of the SQL server database for use while operating with a local database connection.

NOTE: The database connection type will be displayed in the lower left corner when configured to operate with both.

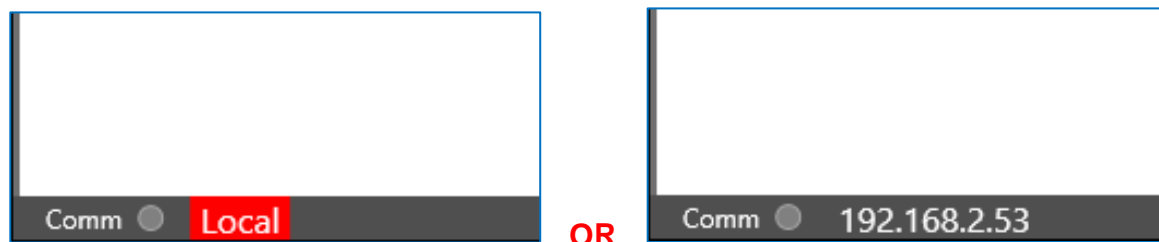

NOTE: To manually change the Database type (local, remote or both) if you haven't selected "both" when installing the software, open the DataPRO.exe.config file in the software folder and modify the "DBType" setting to the following:

- "0" for centralized SQL database;
- "1" for local database;
- "2" for both databases.

Restoring, Importing, and Exporting System Settings

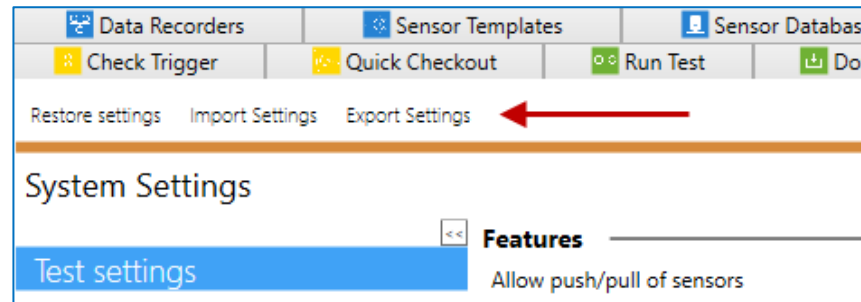

Restore Settings

To restore all System Settings to the original, as-installed factory default settings, select Restore Settings.

NOTE: A single press of this button will revert any changes made in System Settings back to the default.

Import Settings

1. To import the System Settings, select Import Settings.
2. Browse to and select the desired System Settings file that was previously exported.
3. Select Save.

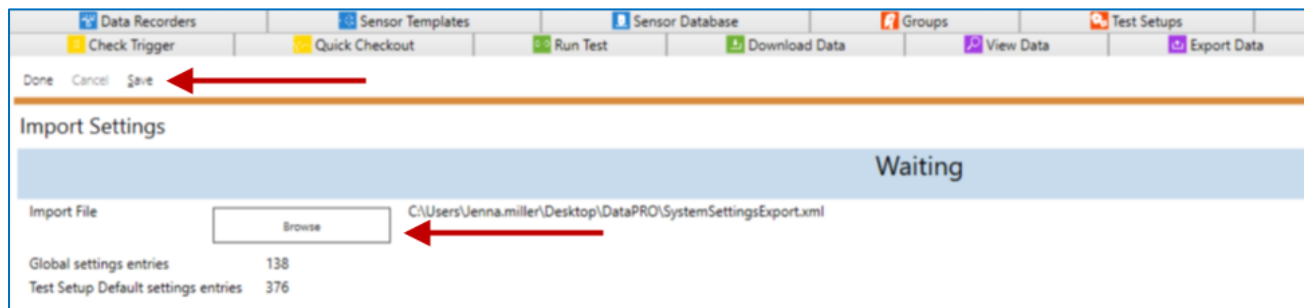

Export Settings

1. To export the System Settings, select Export Settings.
2. Browse to the desired location and enter the name for the export file:
3. Select Export.

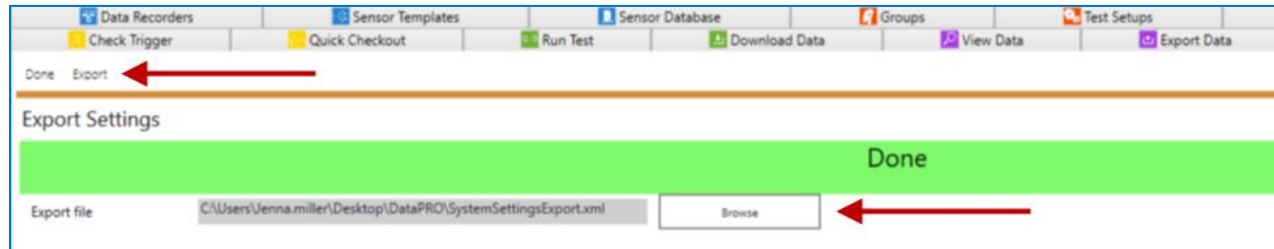

Appendix A: Common Sensor Types and Bridge Connections

The sensor setup application notes are general and apply broadly to categories of sensors. Please contact DTS for more information or with specific questions. Sensor setup information and application diagrams for many commonly used sensors are available on the Help Center. In order to effectively use the connector diagrams, both the pin configuration of the hardware and the wire scheme of the sensor must be known.

See [Sensor Templates](#), page 46, and [Sensor Database](#), page 52, for more information on sensor fields.

NOTE: DTS recommends to always use shunt checks when possible – except for Bridges above 4k Ω , active sensors or unbalanced Bridges.

Accelerometer

- Typical Sensor max range capacity of 400 to 2,000 g
- Typical Units of “g”
- Sensor type is typically “Full Bridge”
- Typical bridge resistance of 500-510 ohms
- Output is Proportional to Excitation
- Enter Sensitivity in mV/V/g

Upper Neck Load Cell

- Enter Sensor max range same as load cell Sensor max range
- Sensor type is typically “Full Bridge”
- Typical bridge resistance of 350 or 700 ohms
- Output is Proportional to Excitation
- Enter Sensitivity in mV/V/N (lbf, etc.)

ARS – Angular Rate Sensors

- Enter Sensor max range same as ARS Sensor max range
- Sensor type is “Full Bridge”
- Equivalent bridge resistance is 3000 ohms
- Output is NOT Proportional to Excitation
- Enter Sensitivity in mV/deg/sec

Linear Potentiometer

- Enter Sensor max range same as potentiometer Sensor max range
- Potentiometer is part of a half or full bridge
- Bridge resistance varies according to design
- Output is Proportional to Excitation
- Do not remove offset
- Enter Sensitivity in mV/V/mm (inch, etc.)

Non-linear Devices

Certain ATD displacement sensors

- Enter Sensor max range same as potentiometer Sensor max range
- Potentiometer is part of a half or full bridge
- Bridge resistance varies according to design
- Sensor is Non-Linear
- Select correct non-linear format
 - Typically, Cubic Polynomial for chest displacement potentiometers
- Enter calibration coefficients into Sensitivity Details table

IRTRACC for WorldSID and THOR dummies

- Enter Sensor max range same as potentiometer Sensor max range
- Potentiometer is part of a half or full bridge
- Bridge resistance varies according to design
- Sensor is Non-Linear
- Select correct non-linear format:
 - IR-Tracc Legacy
 - IR-Tracc Diagnostic Zeroed
 - IR-Tracc mV for 0 mm
 - IR-Tracc Average over time
 - IR-Tracc Radius Cal with Cal Factor – use for NCAP 0 position intercept
- Enter calibration information based on selected non-linear format

Digital Input/Output Options

- All options other than Name can be modified in Group and Test Setup

Squib Options

- All options other than Name can be modified in Group and Test Setup

Sensors with External Conditioning Modules

Contact your Support representative for assistance with setting up these sensors.

- Thermocouples
- Voltage sources

Example SLICE Bridge - Sensor Interface

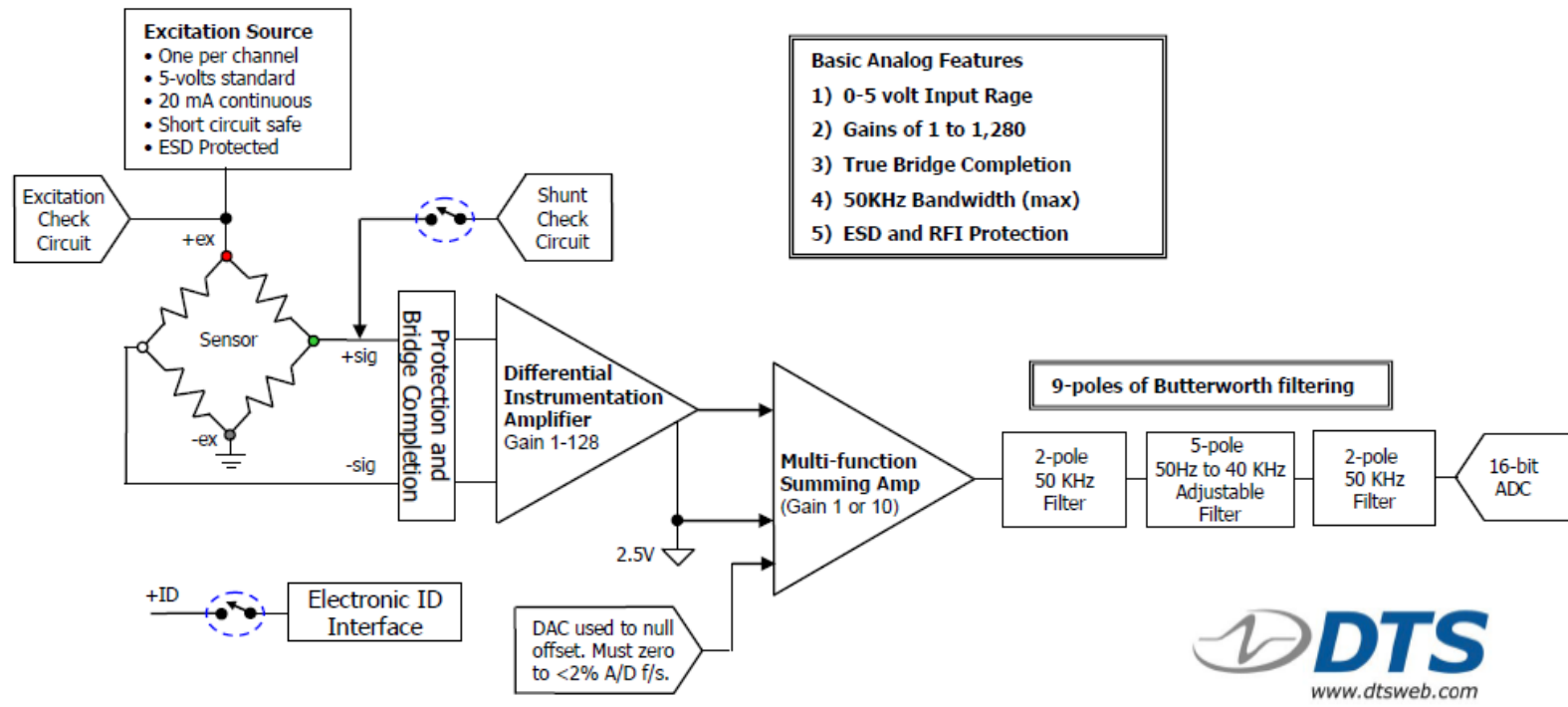

NOTE: Device-specific diagrams are available in the manual for each device.

Standard 4-wire Bridge Connection

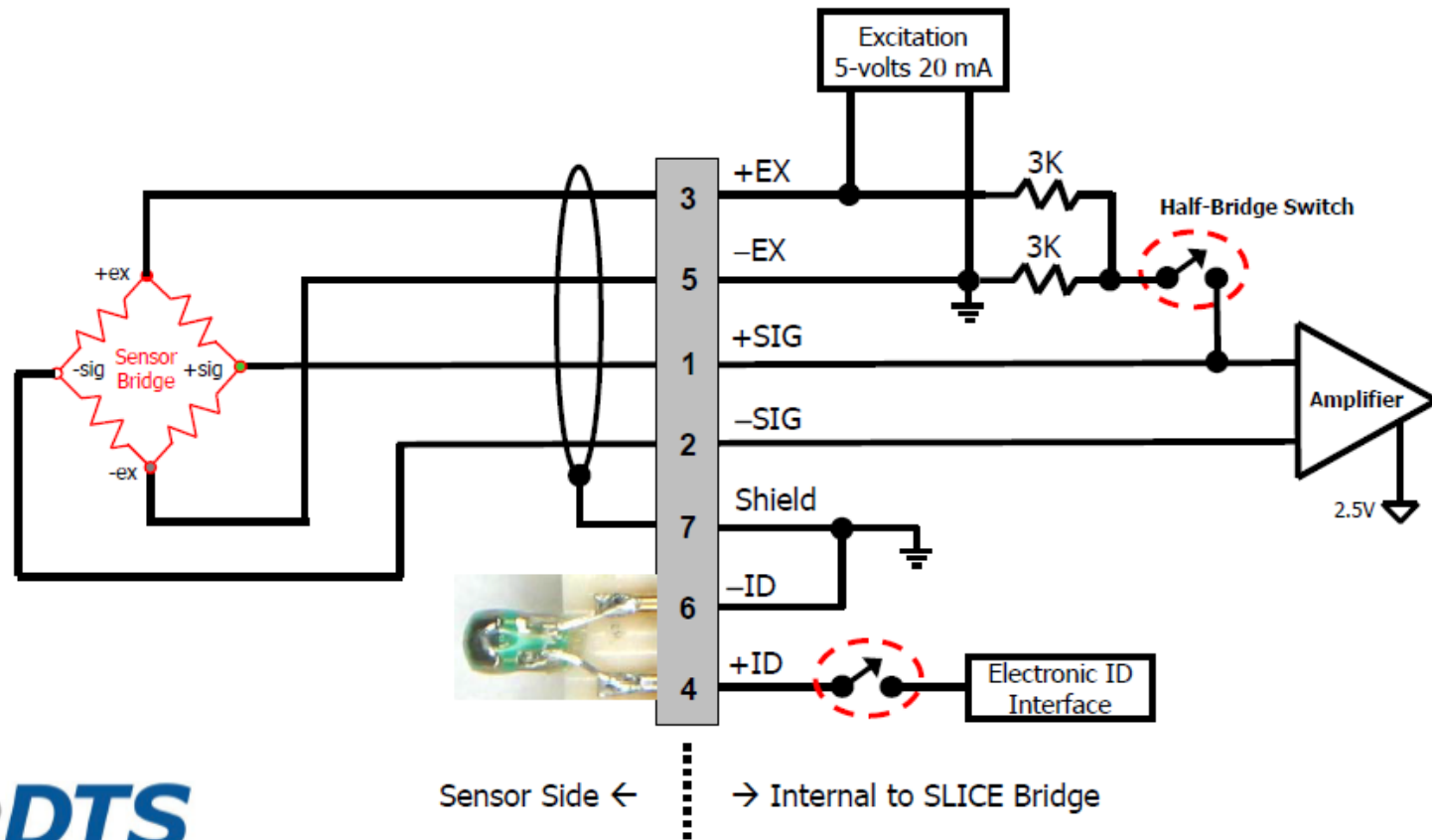

Sensor Side ← → Internal to SLICE Bridge

Strain Gage 3-wire Connection

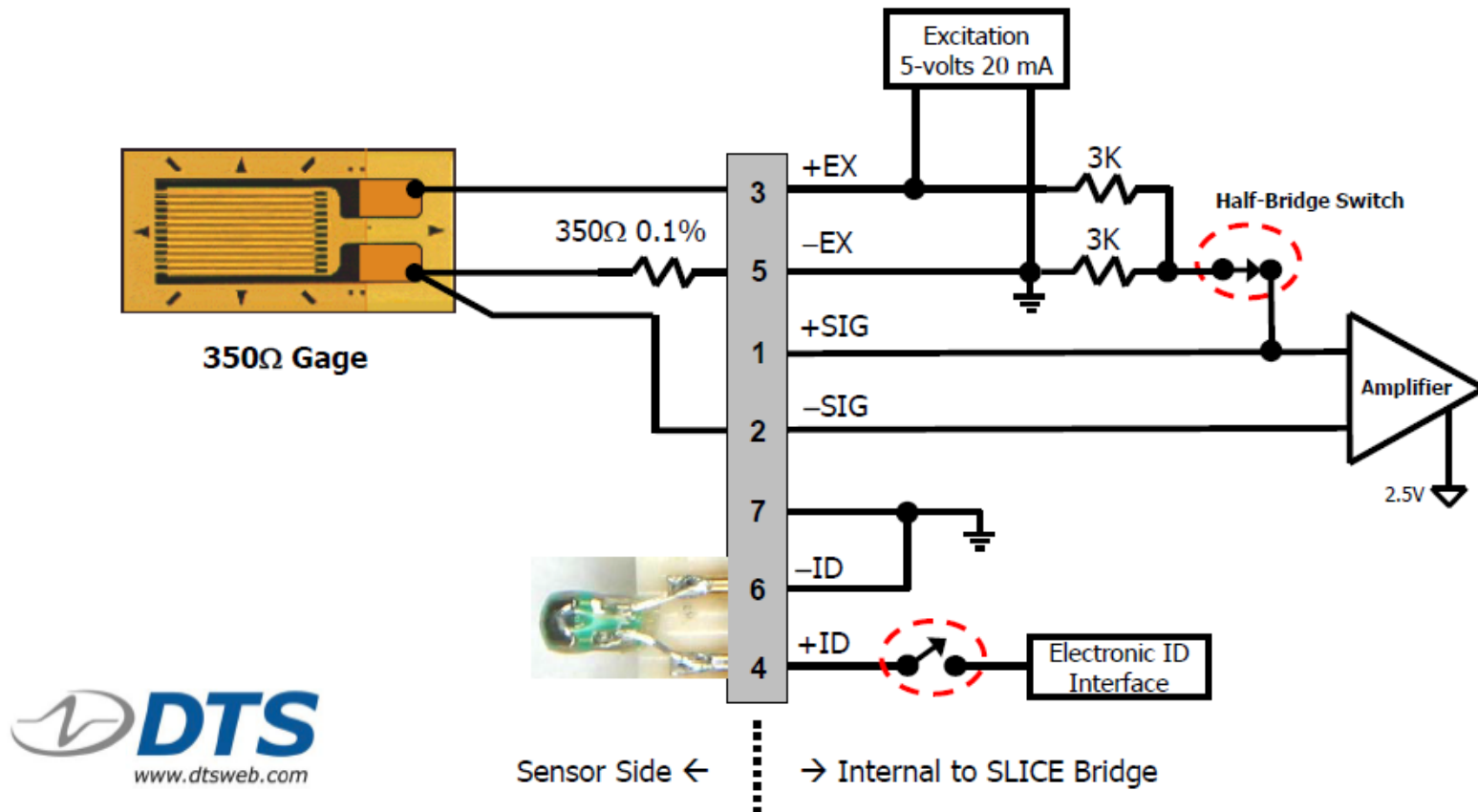

Strain Gage 2-wire Connection

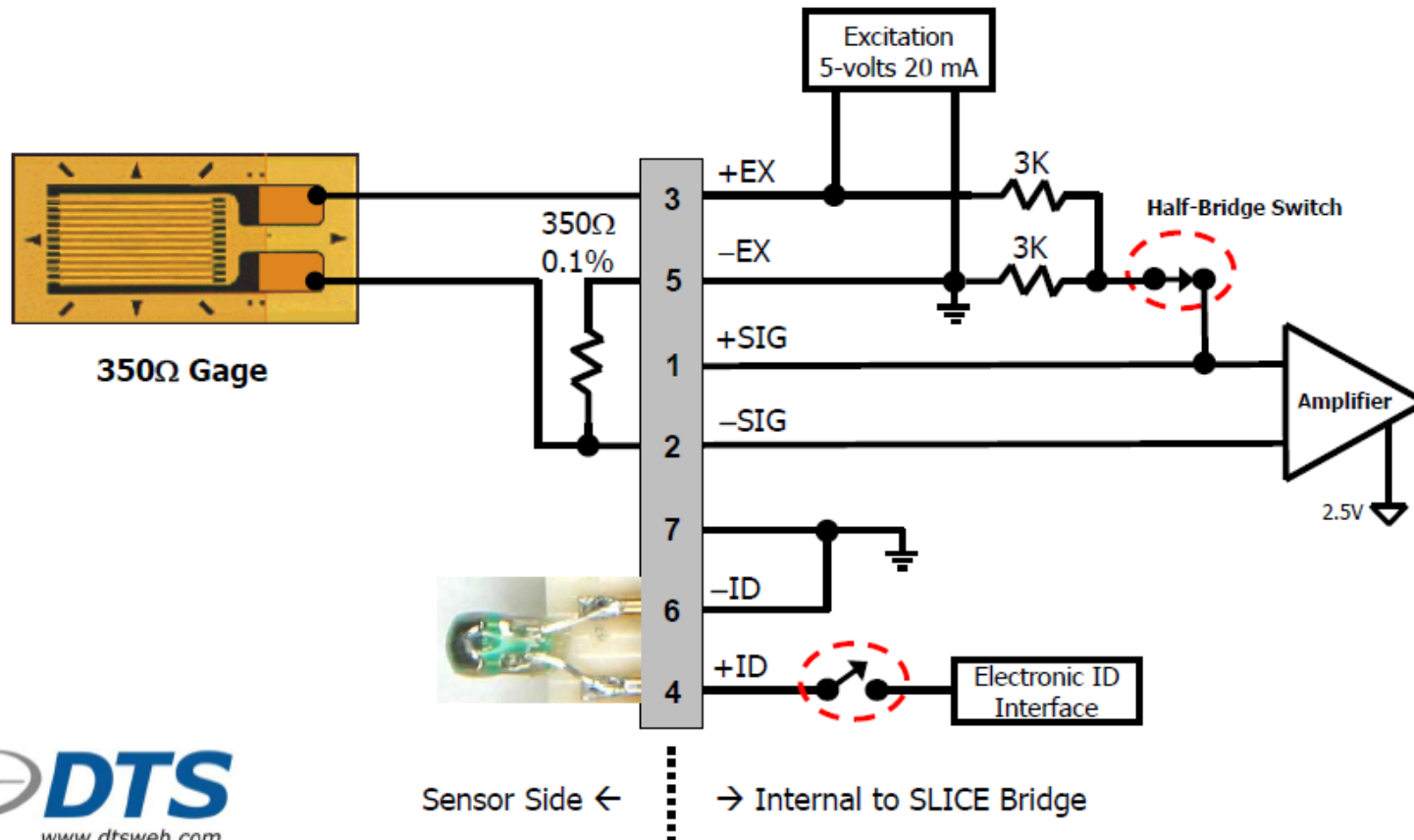

Switch Closure

Example Sensor Settings

- Half-Bridge Mode
- Proportional to Excitation = No
- Sensitivity = 1.000 mV/EU will scale data in mV at input. Switch closure as shown gives 833 mV deflection.

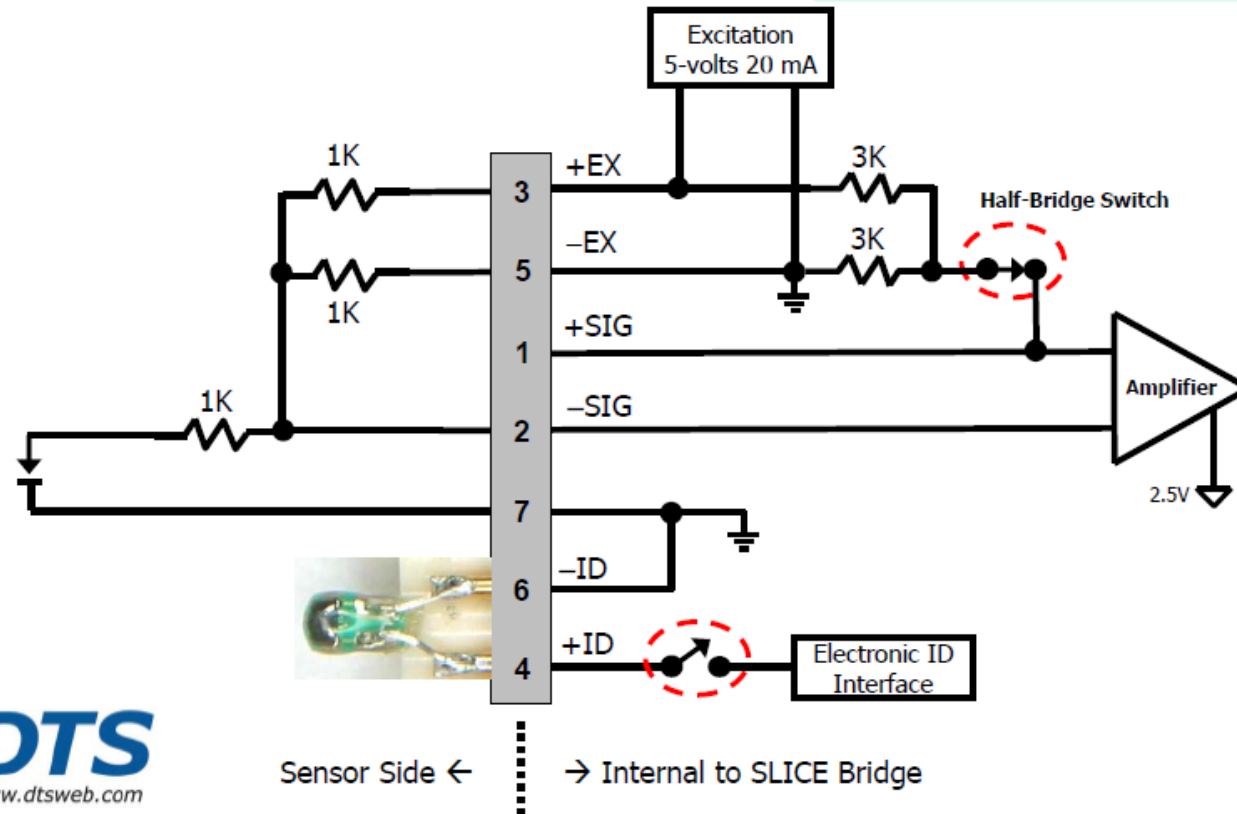

Strain Gage 2-wire Connection

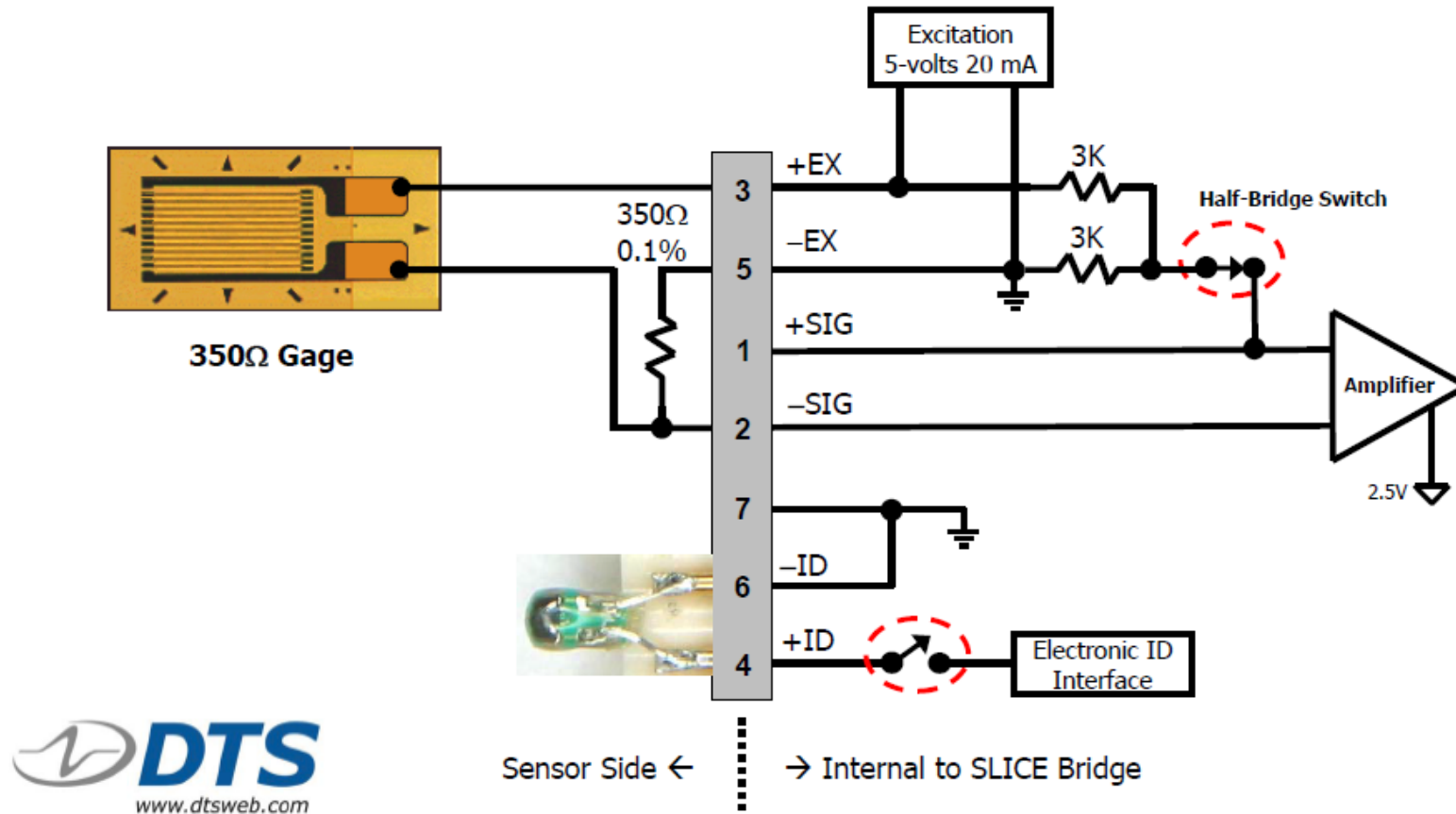

Switch Closure

Example Sensor Settings

- Half-Bridge Mode
- Proportional to Excitation = No
- Sensitivity = 1.000 mV/EU will scale data in mV at input. Switch closure as shown gives 833 mV deflection.

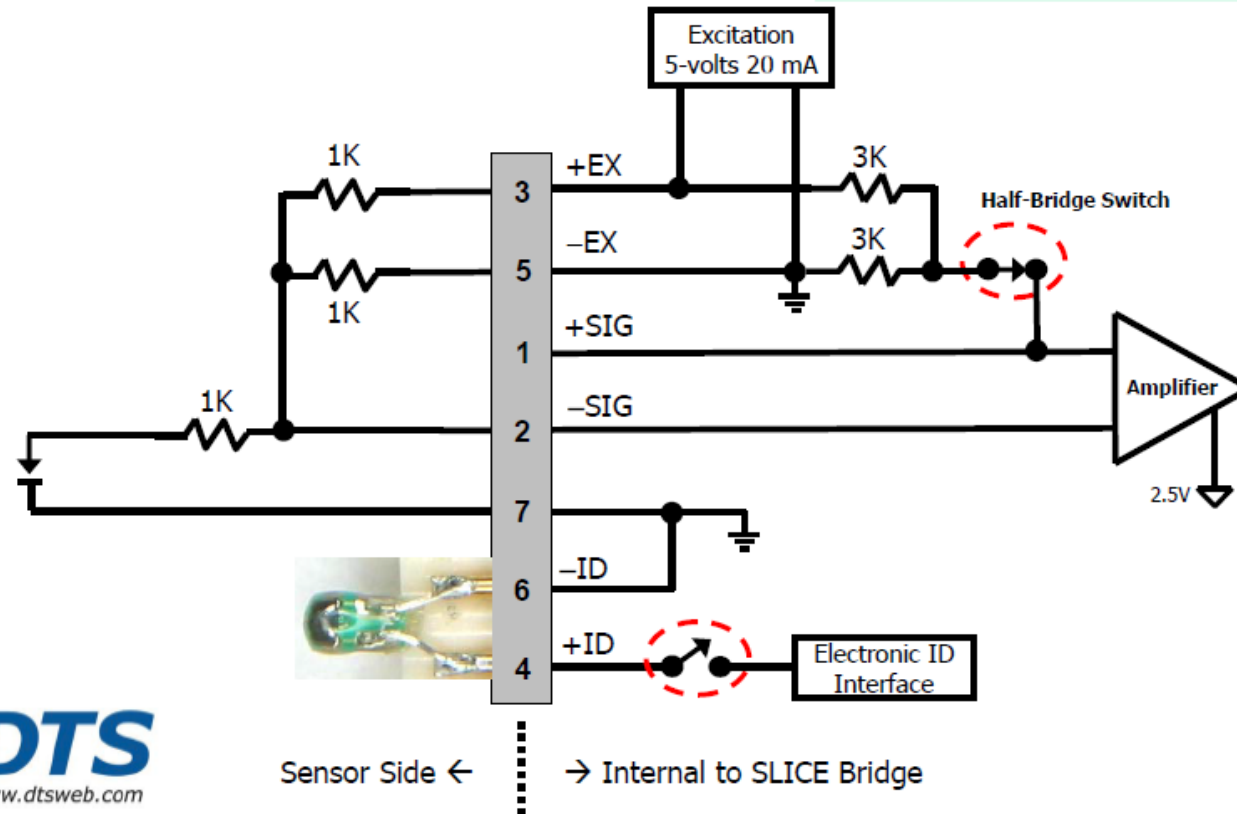

Signal Generator w/floating output

Notes:

- SLICE input range is 0-5 volts WRT SLICE power ground and -Excitation.
- Both sides of input amplifier must be connected either externally or +Signal via ½ bridge mode.
- Signal generator must float WRT ground or alternate connection method must be used.
- Input range does not quite extend to 0 & 5 volts. Best to use signals under 4.5-volts p-p.

Sample Sensor Settings

- Desired Range = 2000
- Sensitivity = 1.000 mV/EU
- Units = mV
- Sensor Type = Half-Bridge
- Proportional to Excitation = No
- Zero Type = None
- Remove Offset = No

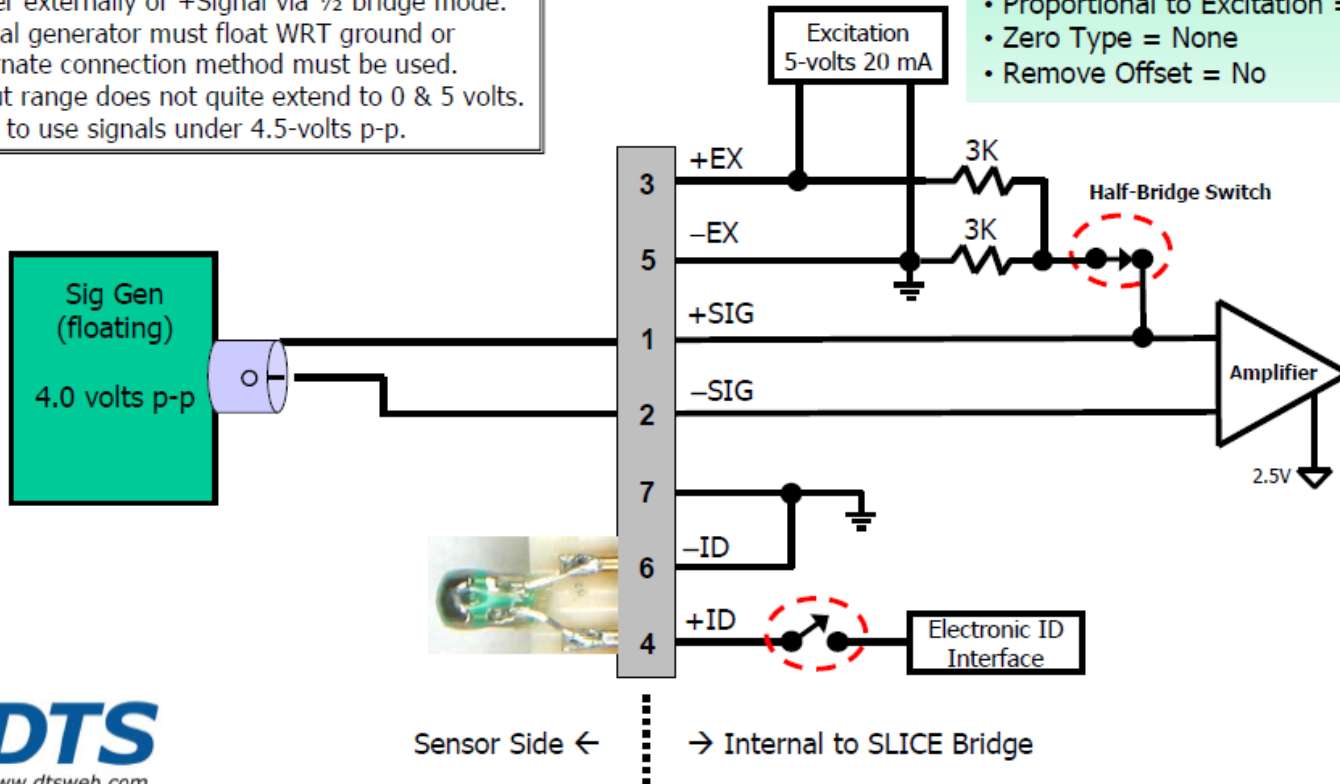

Signal Generator w/grounded output

Notes:

- SLICE input range is 0-5 volts WRT SLICE power ground and -Excitation.
- Both sides of input amplifier must be connected either externally or +Signal via 1/2 bridge mode.
- Signal generator must float WRT ground or alternate connection method must be used.
- Input range does not quite extend to 0 & 5 volts. Best to use signals under 4.5-volts p-p.

Sample Sensor Settings

- Desired Range = 2000
- Sensitivity = 1.000 mV/EU
- Units = mV
- Sensor Type = Half-Bridge
- Proportional to Excitation = No
- Zero Type = None
- Remove Offset = No

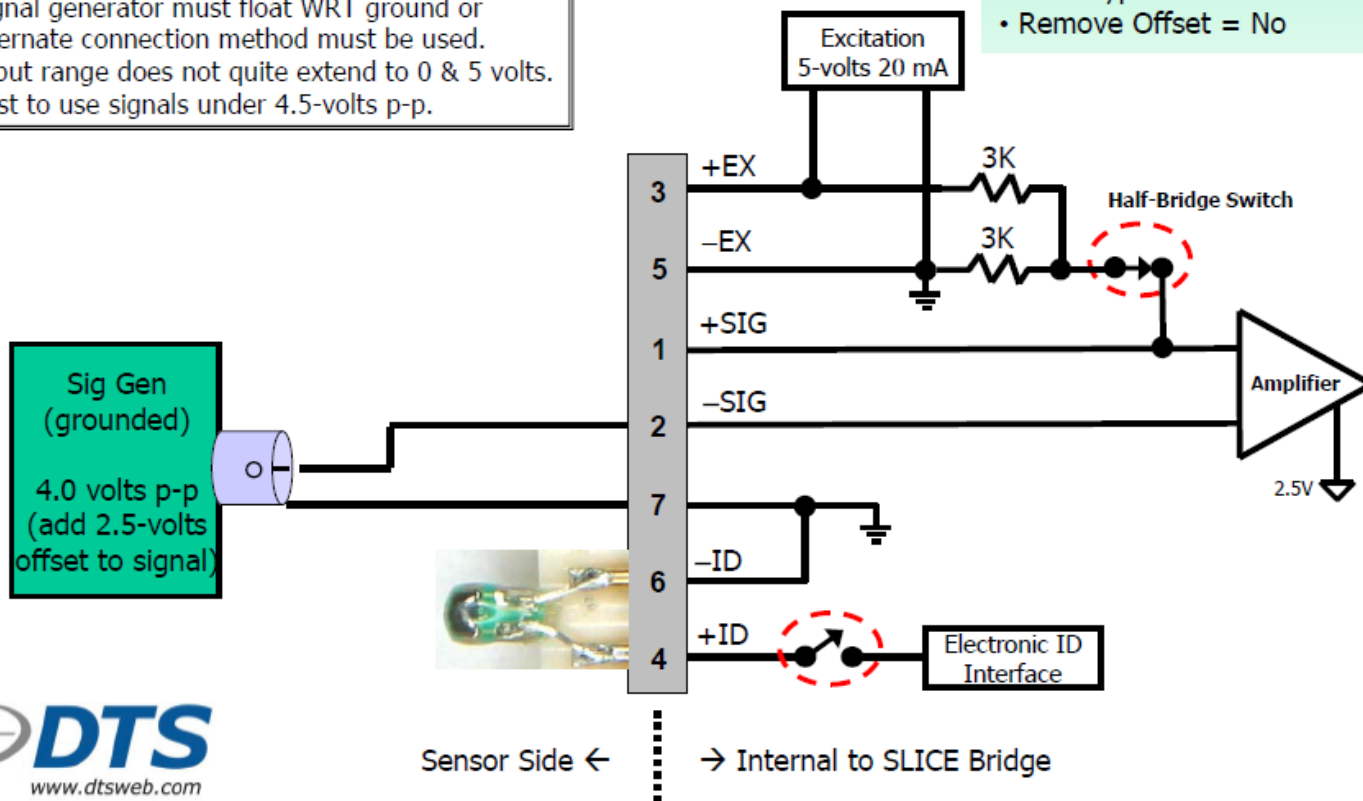

Measuring Large Differential Voltages

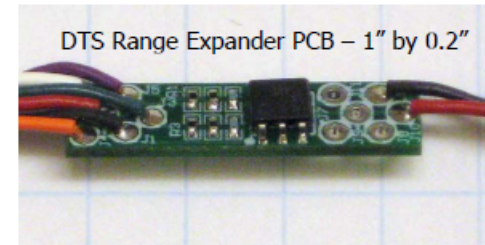
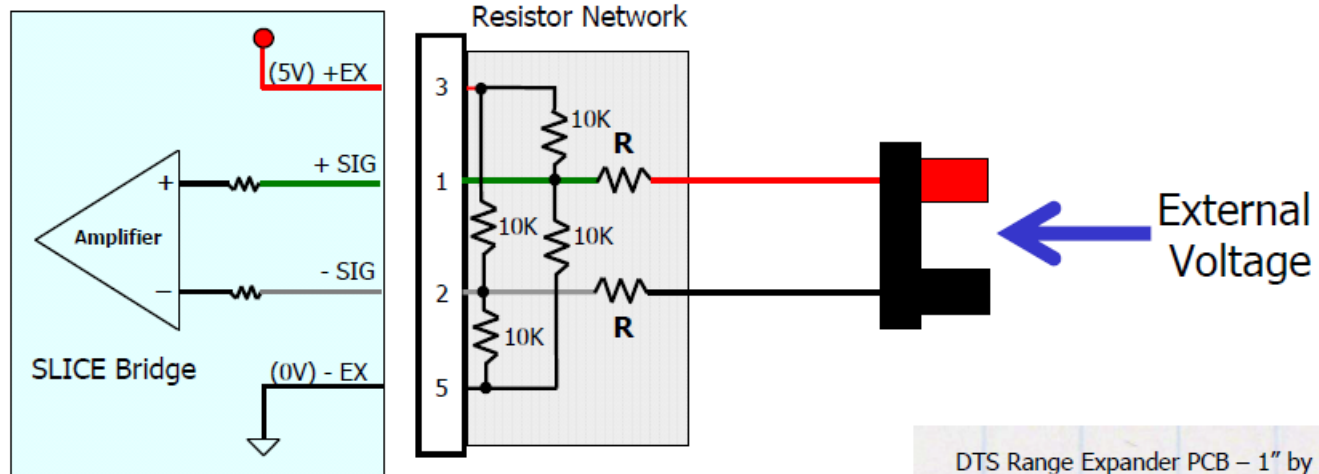

Approx MAX External Voltage V_{max}	Resistance R	* Sensitivity mV/V
+/-20V	49.9K	91.07
+/-40V	95.3K	49.85
+/-60V	150K	32.26

* Sensitivity calculation...

$$\left(\frac{5}{5 + R} \right) \times 1000$$



Appendix B: Sensor Database Import

An existing sensor database can be imported into the DataPRO Sensor Database.

Supported import formats include:

- **DataPRO (*.xml)**
Native DataPRO Sensor Database format. Will import sensors and sensor templates contained in selected file.
- **SLICEWare (*.xml)**
Requires both Data.SensorDB.xml and Calibration.SensorDB.xml in order to import sensor data.
- **TDAS Control Sensor Database**
CSV file created from TDC Sensor Database.
- **Sensor Information File (*.sif)**
Individual Sensor Information Files from TDAS Control.
- **Equipment Exchange (*.e2x)**
DataPRO fully supports e2x version 1.2, with limited support for version 1.5.
- **TDAS Manager CSV Export**
“Sensors” CSV file generated from TDAS Manager.
- **Command Line Import**
A batch file can be run to import a CSV sensor database file.

Command Line Import

DataPRO supports importing sensors from a CSV file using the command line. This allows you to update sensor calibrations or mark sensors as “broken” or “do not use” all at once from a single CSV file. Sensors that are already in the database will only update calibrations when the calibration date in the file is newer than the calibration date in the database. The exception to this is if the import file is marking the sensor as “broken” or “do not use”, in which case a newer calibration date is not required.

Syntax

```
DataPRO.exe /u:<username> /p:<password> /csvimport:<CSV filename> [/csvverbose:<true/false>]  
[/csvimportlog:<true/false>]
```

Parameters

Parameter	Description
/u	The DataPRO login username of the user performing the import.
/p	The password associated with the username.
/csvimport	The CSV input file name/path.
/csvverbose	Set this to true to increase the amount of logging. (Optional—defaults to false)
/csvimportlog	Log file name/path. (Optional—defaults to “Logs/CSVIMPORT_<yyyy>_<mm>_<dd>_<hh>_<mm>_<ss>.log”)

Example

```
C:\DTS\DTS.Suite\4.0.784\DataPRO>DataPRO /u:Admin /p:DTSAdmin /csvimport:"C:\DTS\myExportFile.csv  
/csvverbose:TRUE /csvimportlog:"C:\DTS\ImportLog.log"
```

File Format

The file format is the same as the export format used for the “TDAS Control Sensor Database” export option on the Sensor Database tab. It may be helpful to create an export file as a starting point since the column headers will be included for you. The columns are as follows:

Database Reference Number	Received	Times Used
Sensor SN	Last Cal	IEPE Coupling Mode
Channel Name	Due Cal	DelayMS
Location	Due	DigitalOutputDelayMS
Laboratory Code	Tech	DurationMS
Customer Code	Group 1	DigitalOutputDurationMS
Partial ISO Code	Group 2	Digital Output Mode
Comment Field	Group 3	LimitDuration
Sensor Type	Group 4	Squib Fire Mode
Manufacturer	Group 5	Squib Measurement Type
Model	Category	Squib Output Current
Axis (X, Y, Z)	IRTRACC Exponent	Digital Scale Multiplier
Dimension	Two Volt Exc.	Digital Input Mode
EU	Five Volt Exc.	NonLinear Cal
Full Scale (EU)	Ten Volt Exc.	DisplayUnits
Exc (VDC)	Range Low	At Capacity
Output @ EXC & FS (mV)	Range Medium	Capacity Output Is Based On
Sensitivity (mV/V/EU)	Range High	Sensitivity Units
Output Proportional to EXC? (Yes, No)	Supported Excitation	CheckOffset
Desired Range (EU)	Bridge Type	Broken
BRIDGE (Full, Half)	Unipolar	Do Not Use
Use Shunt Cal? (Yes, No)	Axis Number	ISOChannelName
Bridge Res. (Ohm)	Number Of Axes	UserCode
Shunt Resistor Value (Ohms)	Cal Interval	UserChannelName
Equivalent EU for Shunt Resistor	Polarity	Add Linear Sensitivity
Bypass AA Filter? (Yes, No)	Physical Dimension	Add Linear Zero Method
Invert Signal? (Yes, No)	Direction	Add Linear Zero Method Start
Remove Sensor Offset? (Yes, No)	InitialOffset	Add Linear Zero Method End
Sensor Offset Low (mV)	NonLinear	Add Initial Offsets
Sensor Offset High (mV)	Software Zero Method	
SAE Filter Class	Zero Averaging Window Start	
Software Zero Reference (Pre, Avg, 0mV)	Zero Averaging Window End	
Software Zero Equivalent EU	Bridge Leg Mode	
16 Byte Dallas Sensor ID	Created	

Log File Format

The log file contains dated entries for the following operations:

- **OPENING_FILE:** Indicates the file being opened for sensor import.
- **NOTE:** Extra information, such as the number of sensors in the file (verbose mode only).
- **SENSOREXISTS_NOTIMPORTED:** Indicates the existing sensor in the database is either newer or the same as the imported sensor (verbose mode only).
- **SENSORS_ERRORED:** The total number of sensors that could not be imported because of errors.
- **SENSORSNOT_UPDATED:** The total number of sensors that did not error but were not imported due to being the same or older than the sensor in the database.
- **SENSORS_UPDATED:** The total number of sensors that were added or updated.
- **ERROR:** Indicates an error.
- **FINAL_RESULT:** The final result of the import process.

Appendix C: Discover Hardware

Discover Hardware is a feature that allows in-process addition of connected hardware to the database and discovery of connected sensors with EID. This feature is available in both Groups and Test Setups.

All hardware to be discovered and added to the database must be powered on and connected. All sensors to be discovered must a) already exist in the sensor database, b) be connected and c) have EID installed.

1. To quickly add DAS to the data recorder database, or to detect powered on and connected DAS (and sensors with EID), select “Discover Hardware”:

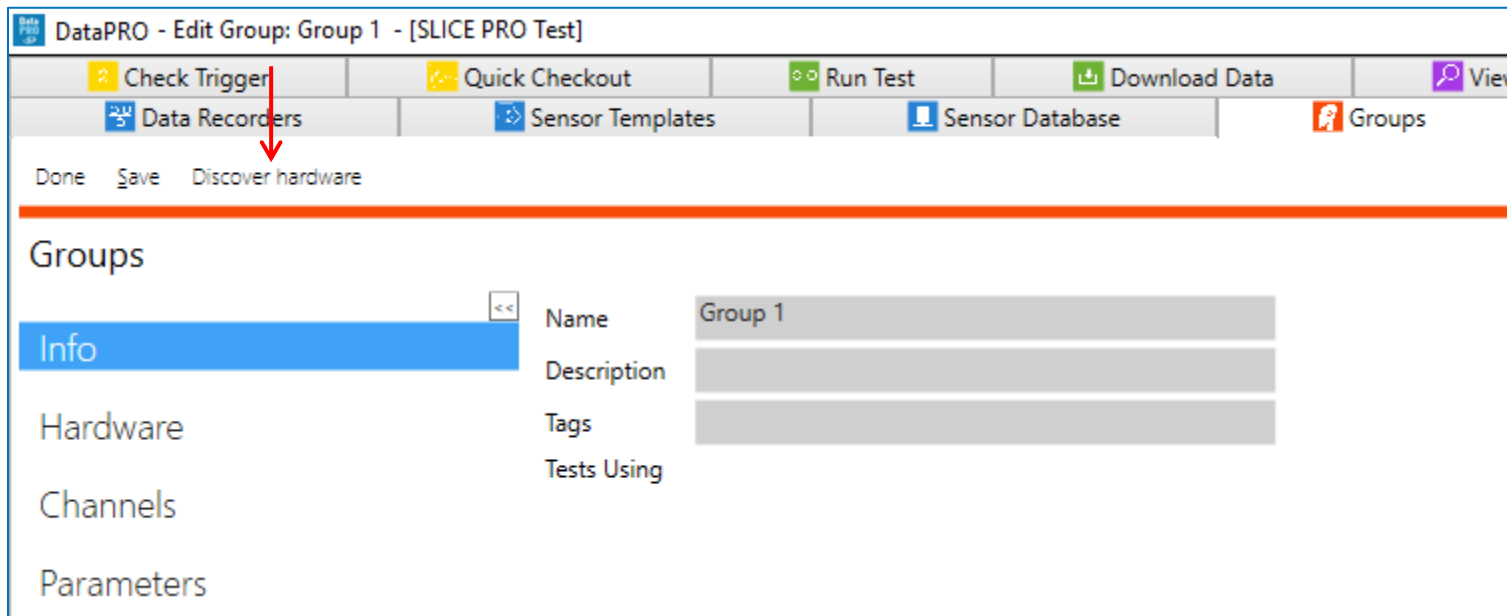

- DAS that are already in the database will be listed in the Available DAS table. DAS that have been added to the group will be listed in the Included DAS table:

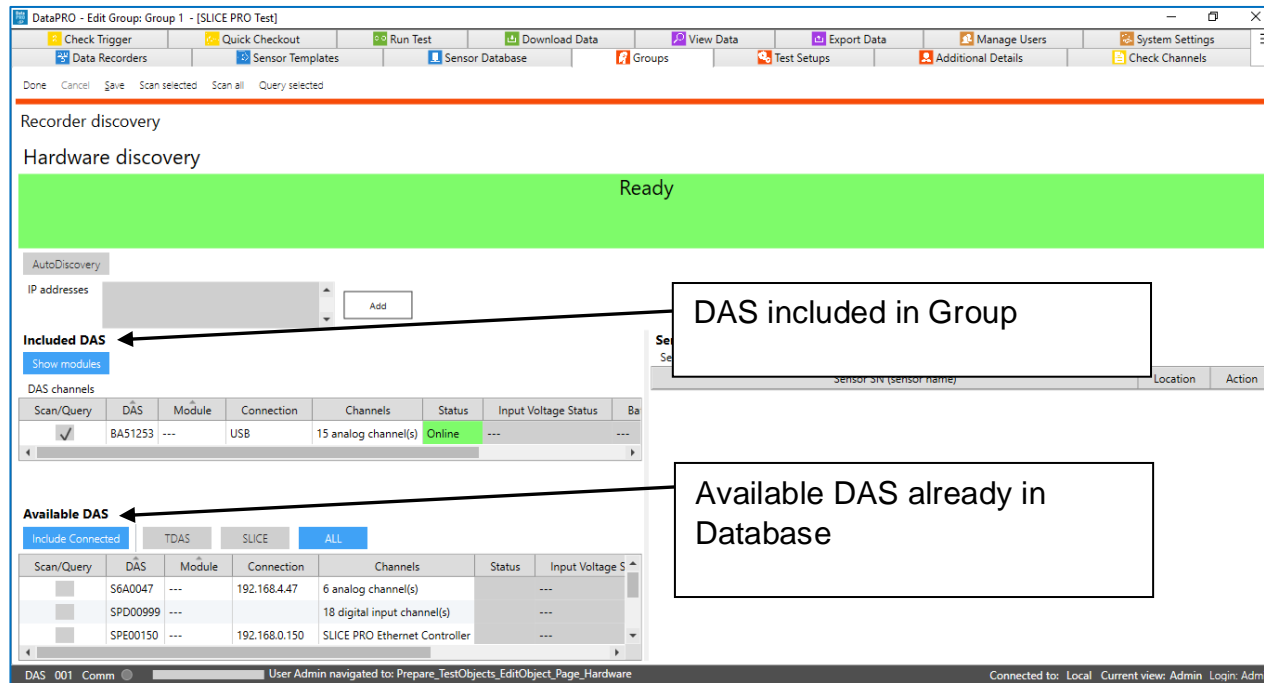

- To add new Ethernet DAS to the database, enter the IP address and select “Add”. USB connected DAS will be discovered automatically during the scan:

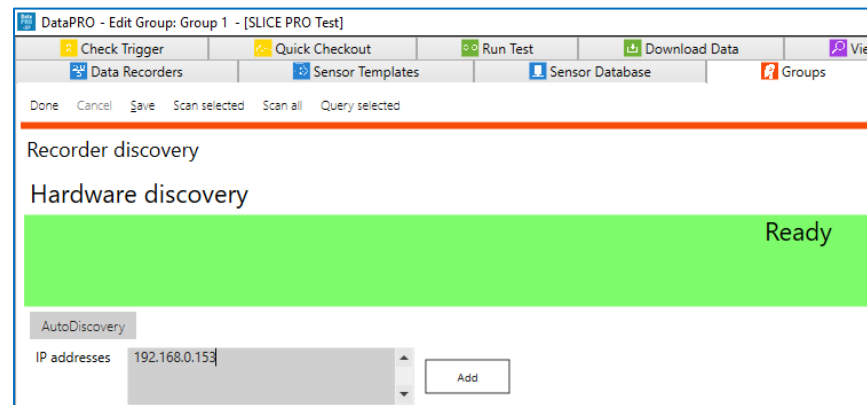

a. If IP address(es) are not known, enable “AutoDiscovery” to ping all available IP addresses in the compatible range:

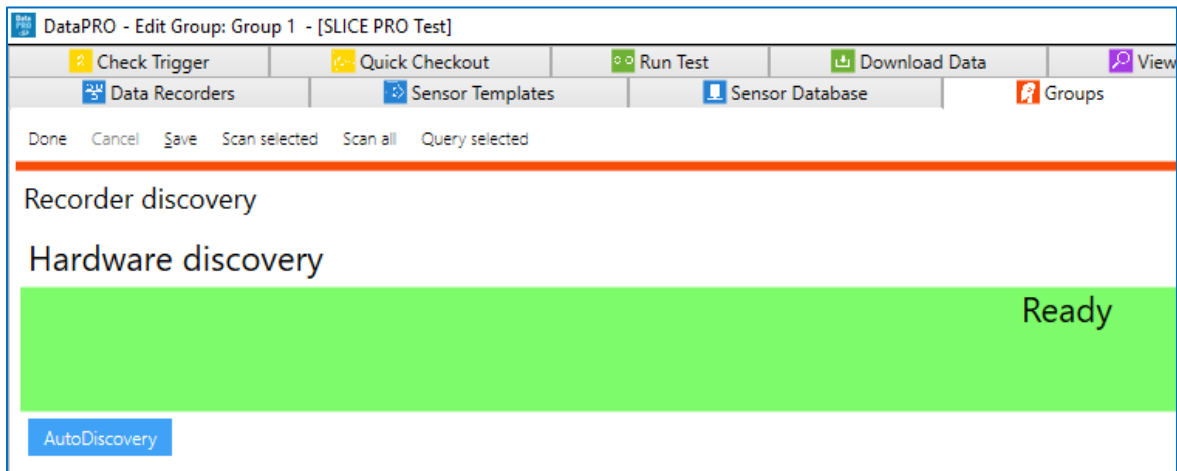

4. Select “Scan all” or “Scan selected” to confirm IP address(es) and discover USB DAS:

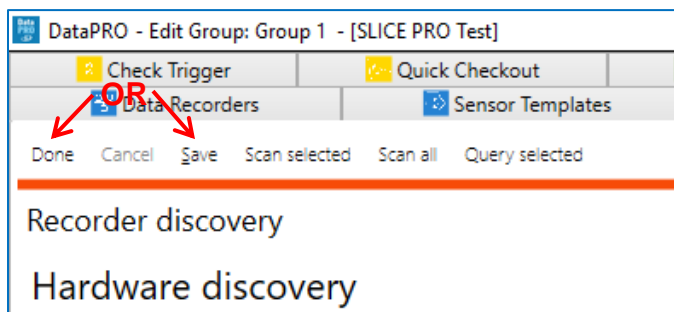

5. Select “Query selected” to establish communication and confirm DAS configuration. DAS that is powered on and connected will be displayed in the Included DAS table. Connected sensors with EID will be displayed in Sensors table:

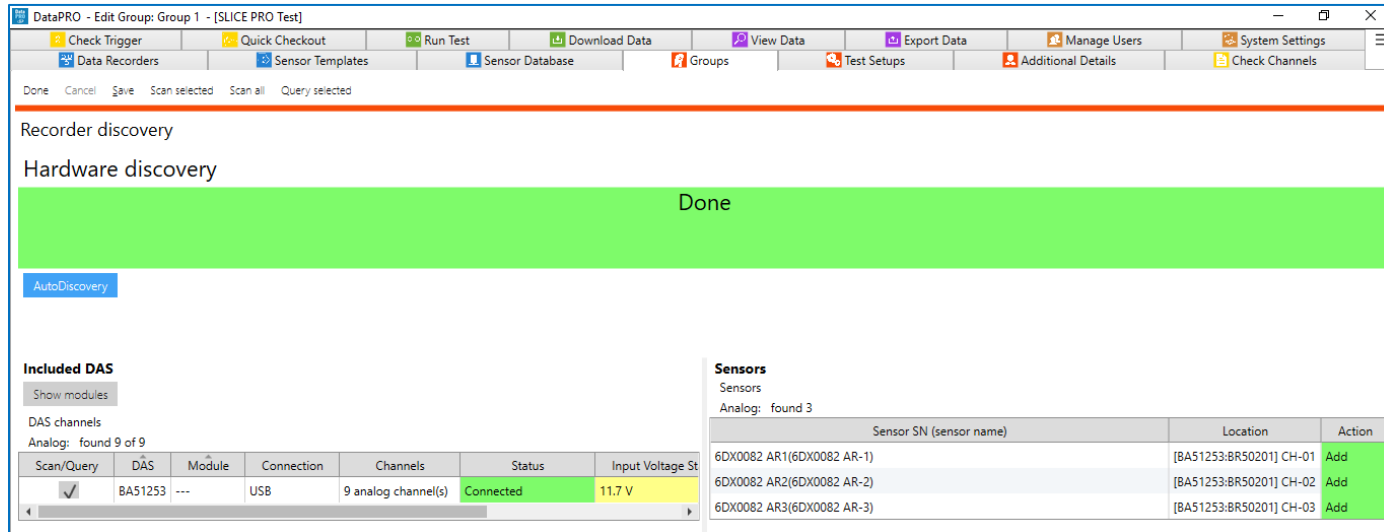

- a. Enable “Show modules” to display modules (SIM/TOM/Bridge) connected to each DAS (TDAS Rack, ECM, Base):

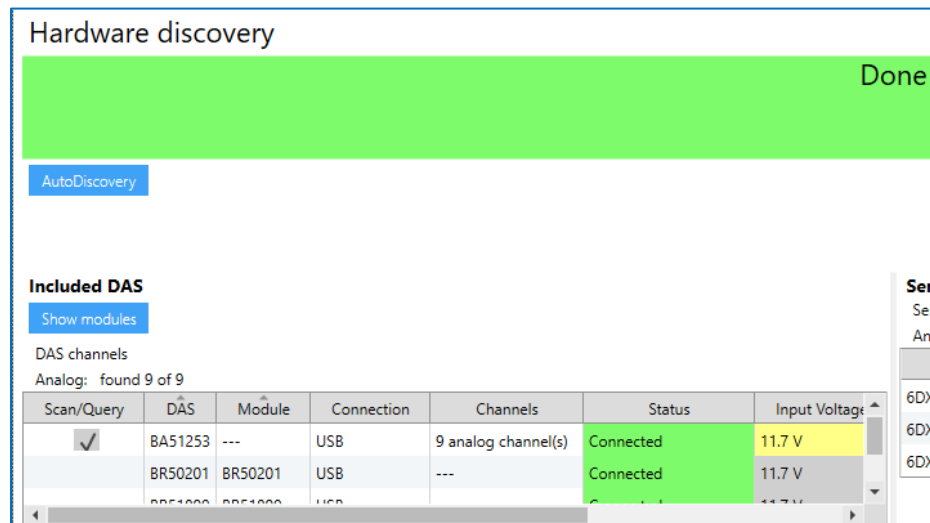

- Once DAS has been discovered and added to the database, it can be removed from the group by selecting “Remove” from the Discover Hardware screen or by unselecting the box from the Hardware navstep:

Remove DAS from group by selecting “Remove” on Discover Hardware screen.

Included DAS

Show modules

DAS channels

Analog: found 9 of 9

Scan/Query	DAS	Module	Connection	Channels	Status	Input Voltage Status	Battery Voltage Status	Action
<input checked="" type="checkbox"/>	BA51253	---	USB	9 analog channel(s)	Connected	11.6 V	---	Update Remove
	BR50201	BR50201	USB	---	Connected	11.6 V	---	Update
	BR51890	BR51890	USB	---	Connected	11.6 V	---	Update

Remove DAS by unselecting box on Hardware navstep.

DataPRO - Edit Group: Group 1 - [SLICE PRO Test]

Check Trigger Quick Checkout Run Test Download Data View

Data Recorders Sensor Templates Sensor Database Groups

Done Save Discover hardware

Groups

Search

0 channels required, 9 physical channels included.

Info Compact Expanded

Hardware Channels Parameters

	Serial Number	Type	Channels	Firmware
<input type="checkbox"/>	SPT00999	SLICE PRO TOM	4 Squib,8 Digital out	D0D7
<input type="checkbox"/>	SPT00107	SLICE PRO TOM	4 Squib,8 Digital out	D0L0
<input type="checkbox"/>	SPS00331	SLICE PRO SIM	18 Analog	A1Q1
<input type="checkbox"/>	SPE00150	SLICE Ethernet Controller	---	B0B3
<input type="checkbox"/>	SPD00999	SLICE PRO DIM	18 Digital input	A1J4
<input type="checkbox"/>	S6A0047	SLICE 6 AIR	6 Analog	G0I5
<input checked="" type="checkbox"/>	BA51253	SLICE+	9 Analog	B1F4

7. Select “Save” to add the discovered DAS to the database and to the group:

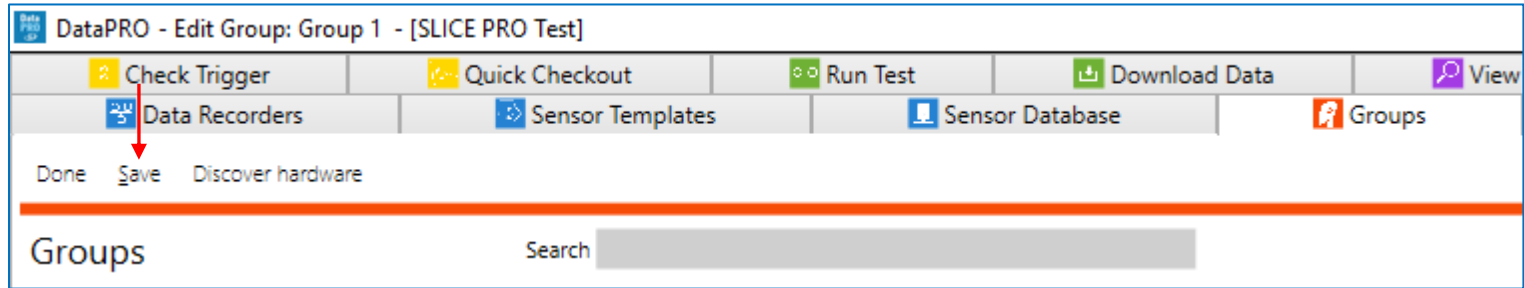

8. Select “Done” to return to the Groups home screen:

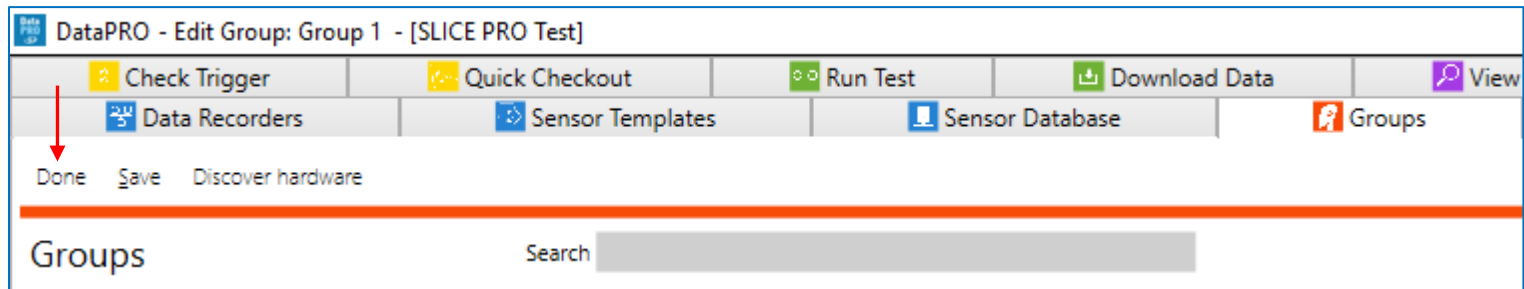

Appendix D: Quick Arm

Quick Arm is a feature that will add an additional Arm Prepare sub-navstep to the Arm navstep. This allows the TOM to remain un-armed until the full system is armed, thereby allowing for shorter DAS set times and helping to ensure safety when conducting time-sensitive airbag deployment tests.

Configuring the system to use Quick Arm requires modifying the *DataPRO.exe.config* file as well as changing the default Test Settings in System Settings.

Config file settings:

1. With DataPRO closed, open the *DataPRO.exe.config* file with a text editor.
2. Change the following settings:
 - a. “ArmArmPrepareStepCheckTOMSafety”.
 - i. Default setting is True.
 - ii. Change to False to enable Quick Arm.
 - b. “ArmIncludeArmPrepareStep”.
 - i. Default setting is False.
 - ii. Change to True to enable Quick Arm.
 - c. “ArmChecklistRequiredIfTOM”.
 - i. Default setting is True.
 - ii. Change to False to enable Quick Arm.
3. Save and close the *DataPRO.exe.config* file.
4. Launch DataPRO.
5. Go to the System Settings tab.
6. Under Test Setup Settings, scroll down to “(5) Arm checklist”.
7. Disable “Require arm checklist when TOM present”.

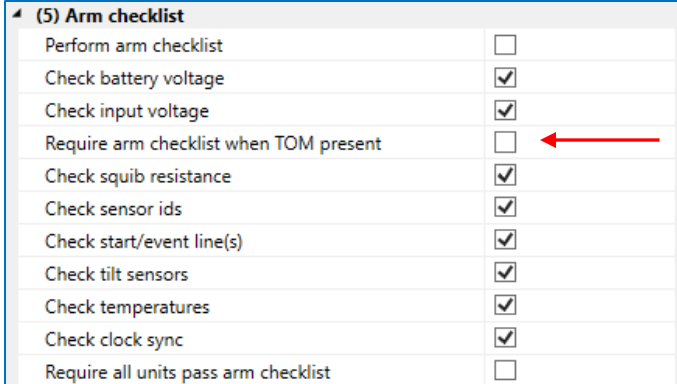

(5) Arm checklist	
Perform arm checklist	<input type="checkbox"/>
Check battery voltage	<input checked="" type="checkbox"/>
Check input voltage	<input checked="" type="checkbox"/>
Require arm checklist when TOM present	<input type="checkbox"/>
Check squib resistance	<input checked="" type="checkbox"/>
Check sensor ids	<input checked="" type="checkbox"/>
Check start/event line(s)	<input checked="" type="checkbox"/>
Check tilt sensors	<input checked="" type="checkbox"/>
Check temperatures	<input checked="" type="checkbox"/>
Check clock sync	<input checked="" type="checkbox"/>
Require all units pass arm checklist	<input type="checkbox"/>

8. Arm Prepare sub-navstep will be present in Arm navstep of the Test Setups tab:

Recording Mode: Circular buffer Samples Per Seconds: 10,000 Channels: 6 (4 analog, 2 SQUIB, 0 digital input, 0 digital output)
 Pre-Trigger Seconds: 1.00 Post-Trigger Seconds: 1.00 Level Triggers: None

Waiting for user selection

Trigger: waiting Faults: clear

Group	DAS	Test sample rate	Input Voltage Status	Battery Voltage Status	Time left in arm	Triggered	Faults	Status
Test channels	SPE00150	---				<input type="checkbox"/>		
Test channels	SPS00331	10,000	12.3 V	8.4 V (Charging)		<input type="checkbox"/>		
Test channels	SPT00107	10,000	12.3 V	8.4 V (Charging)		<input type="checkbox"/>		

a. Arm Prepare configures system:

Recording Mode: Circular buffer Samples Per Seconds: 10,000 Channels: 6 (4 analog, 2 SQUIB, 0 digital input, 0 digital output)
 Pre-Trigger Seconds: 1.00 Post-Trigger Seconds: 1.00 Level Triggers: None

Arm Prepare complete. Waiting for user selection.

Trigger: waiting Faults: clear

Group	DAS	Test sample rate	Input Voltage Status	Battery Voltage Status	Time left in arm	Triggered	Faults	Status
Test channels	SPE00150	---				<input type="checkbox"/>		
Test channels	SPS00331	10,000	12.3 V	8.4 V (Charging)		<input type="checkbox"/>		Done 100%
Test channels	SPT00107	10,000	12.3 V	8.4 V (Charging)		<input type="checkbox"/>		Done 100%

b. TOMs do not have to be Armed until Run is selected (Enabled after Arm Prepare is completed):

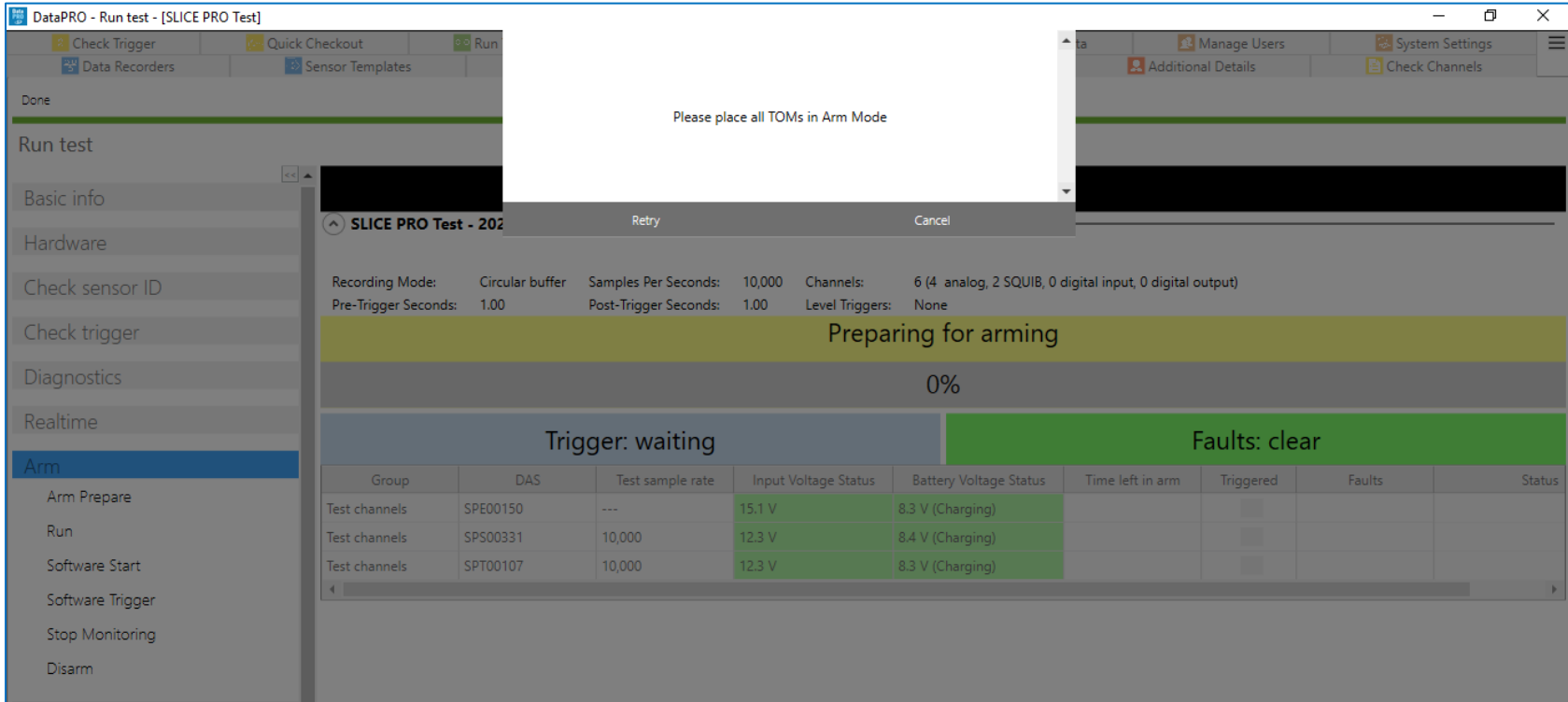

9. Continue data collection from Run Test, select Run to arm the system.

Appendix E: DataPRO File Structure

NOTE: All locations listed below are default installation locations.

C:\DTS\DTS.Suite

Contains DataPRO software organized in folders by version number.

C:\DTS\DTS.Suite\SensorDatabase

Contains sensor database export files for all versions of DataPRO.

C:\DTS\DTS.Suite\ImportArchive\<test ID>

Contains xml backup of a TTS Test Setup import.

C:\DTS\DTS.Suite\Data

Contains data files organized in folders by Test Setup/Test ID. This file location is used for all versions of DataPRO.

C:\DTS\DTS.Suite\Data\<test setup name>

Contains test data organized by unique Test ID for a given test setup.

NOTE: All instances of Diagnostic tabs automatically generate a new test data folder. Instances of Run Test generate a new test data folder on progressing to Hardware navstep.

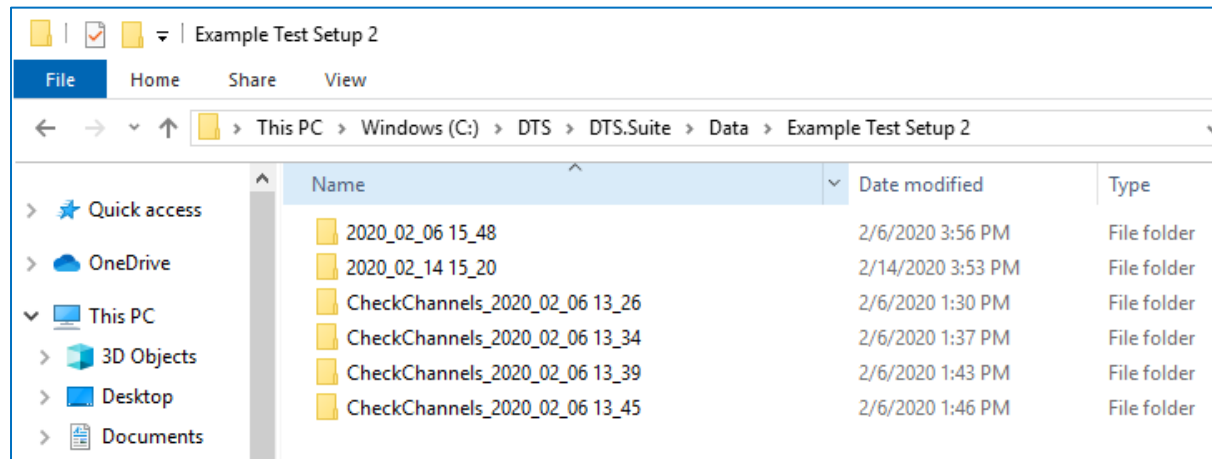

C:\DTS\DTS.Suite\Data\<test setup name>\<test ID>\Binary\<ROI or ALL>

Contains channel data files (.CHN) from a given test. Sub-folders for ALL vs ROI will be present based on user's selection during download. UART data collected with SLICE6 AIR will be saved as a .bin file.

C:\DTS\DTS.Suite\Data\<test setup name>\<test ID>\DASConfigs

Contains the xml configuration file for each DAS with sensor(s) and recording parameters. These files can be used for re-importing tests that have already been run or in certain emergency download situations.

C:\DTS\DTS.Suite\Data\<test setup name>\<test ID>\Exports

Contains test data in the user-selected export format(s) (DIAdem, CSV, ISO, TTS, RDF, TDAS, TDMS, TSV, HDF, Excel) after test completion.

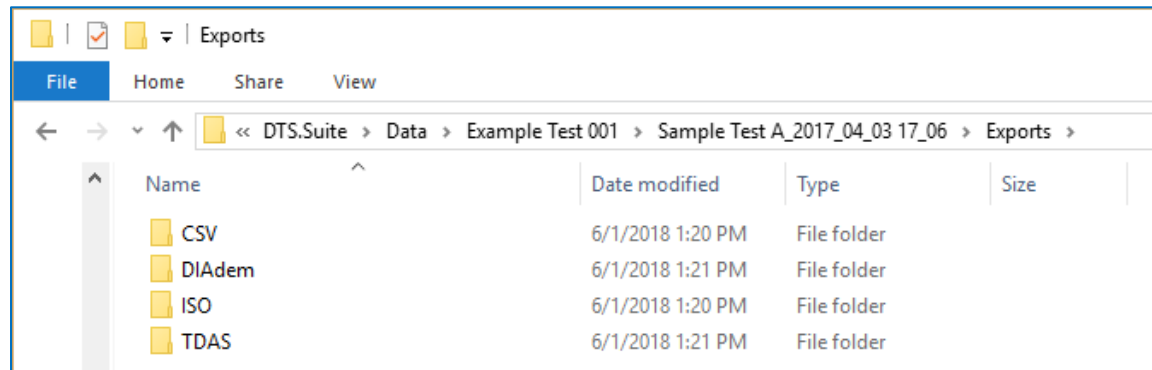

C:\DTS\DTS.Suite\Data\<test setup name>\<test ID>\Logs

Contains log files generated during instance of Diagnostic tab or data collection. Some log files are limited in size and will create archived, *.bz2 files. These archived files will include the date and timestamp as they are created.

- IP Address.log: A heartbeat log for each Ethernet device in the test.
- DASConfigs.log: Configuration information for all DAS included in the test.
- DataPRO.log: Communication and information generated between software, firmware and DAS during instance of Diagnostic tab or data collection.
- Ping.log: Log of ping attempts during instance of Diagnostic tab or data collection.
- TDAScomm.log: Communication and information generated between TDAS PRO hardware, software and firmware during instance of Diagnostic tab or data collection.

C:\DTS\DTS.Suite\Data\

Contains test reports and summaries for the hardware channels included in the test. PDF versions of reports can be enabled in the config file.

- Layout Reports: Created when leaving Check Sensor ID navstep. One report generated for each DAS included in test. Sensor serial number, hardware channel connection, sensitivity, filter and excitation voltage are recorded. ISO Code, level trigger parameters, squib fire mode, delay and duration are also recorded if applicable to the channel.
- Channel Calibration List: Created when leaving Check Sensor ID navstep. Lists all channels used in test with ISO Code, channel name, sensor serial number, sensor name, manufacturer, sensitivity, calibration date and calibration due date.
- Post-test Diagnostics: Created during Post Test Diagnostics, if included in Test Setup. Report with results from post-test diagnostics, if included in test.
- Pretest Diagnostics: Created after Diagnostics is run. Report with results from pre-test diagnostics.
- Test Summary: Created when leaving Basic Info navstep. Report that includes DAS/DAS information, Channels and channel configuration and ISO export information.
- Squib Resistances: Created after Arm Checklist is complete. Report that is included if Squib Resistance measurement is performed during Arm Checklist, contains squib resistance measurements if squibs are included in test.

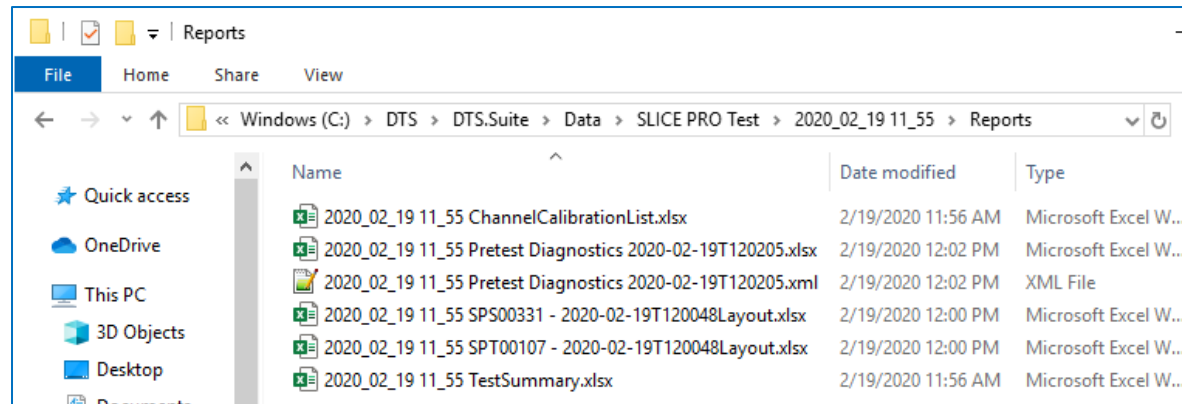

C:\DTS\DTS.Suite\

Contains current configuration file(s) for DAS in Database.

C:\DTS\DTS.Suite*<version number>*\DataPRO\db

Contains DataPRO database files (includes sensors, DAS, group templates, groups, test setups, etc.).

NOTE: *The db files should not be opened or modified outside of DataPRO.*

C:\DTS\DTS.Suite*<version number>*\DataPRO\Logs

Contains log file(s). To assist troubleshooting, DTS Support may ask you to send these files.

C:\DTS\DTS.Suite*<version number>*\DataPRO\Manuals

Contains manuals for SLICE equipment and DataPRO software that are current at time of software release.

C:\DTS\DTS.Suite*<version number>*\DataPRO\ReportTemplates

Contains default and user-defined report templates. Changes or additions to Report Templates must be manually carried over to new versions of DataPRO.

C:\DTS\DTS.Suite*<version number>*\DataPRO\Sounds

Contains files used for Realtime Level Triggers. Beep.wav is the sound when the sensor is idle/blow the trigger threshold, TriggeredBeep.wav is the sound when the sensor has reached the trigger threshold. Either file can be replaced, but the naming convention must remain the same.

C:\DTS\DTS.Suite*<version number>*\DataPRO\TMTEemplates

Contains the TMATS files used for SLICE6 AIR and TSR AIR streaming applications. The files included with DataPRO support the following UDP Streaming Profiles:

- Ch10 Analog
- Ch10 Analog Time Format 2
- Ch10 128bit PCM
- Ch10 128bit PCM Time Format 2
- TmNS 144bit PCM
- TmNS Supercom (4xADCscan) PCM

Appendix F: DataPRO .dts File Format

The .dts file is an XML-based file that contains information about the overall test and the individual channels. Some of the information may be redundant with information stored in the binary channel header.

The attributes and relationships of each XML node are described below.

<Test>

The Test tag is the outer most tag. It contains the following attributes and describes details common to the entire test.

Name	Data Type	Description
Test Id	String	The name of the Test Setup, as well as the name of the subfolder in the "Data" folder which contains the data, reports and exports for all occurrences of runs of this Test Setup (further organized by the "Test Id" which may be modified by the user in the "Basic info" step of the "Run Test" tab). The "Test Id" is typically the same as the .dts file name.
Description	String	The text optionally modified by the user in the "Description" field of the "Basic info" step of the "Run Test" tab.
Guid	Windows UUID string	A unique identifier assigned to each event.
FaultFlags	Integer (UInt16)	16-bit bit array <ul style="list-style-type: none">• Bit 0: Incoming status line dropped• Bit 1: ADC Buffer Overrun• Bit 2: Flash CRC Error• Bit 3: Trigger before start• Bit 4: Input voltage low• Bit 5: Input voltage high• Bit 6: Backup voltage low• Bit 7: Backup voltage high• Bit 8-15: Unused
Software	String	Identifies DataPRO as the software used for data collection.
SoftwareVersion	String	Identifies the version of DataPRO used.

<Modules>

Within the Test node is a list of modules contained within a <Modules></Modules> tag. Module definitions depend on the DAS type. A <module> corresponds to a SLICE MICRO or NANO Base; a SIM, TOM or DIM in a TDAS PRO Rack; 1 of 4 internal, 8-channel modules in a TDAS G5 DAS; 1 of 6 [or 1 of 3] internal, 3-channel modules in an 18-channel [or 9-channel] SLICE PRO SIM or DIM; or an entire SLICE PRO TOM.

Name	Data Type	Description
AaFilterRateHz	Integer	The name cut off frequency of the hardware anti-alias filter used during the test.
Number	Integer	A sequential number assigned to each module within the test.
SerialNumber	String	The factory assigned serial number of the SLICE Base.
BaseSerialNumber	String	For TDAS modules installed in a rack, this is the rack's serial number. All other DAS use the unit's serial number.
NumberOfSamples	Integer	The number of samples stored in each channel file. This will be fewer than the number of samples originally requested by the user if the data has been subsampled or if only a portion of the data was downloaded.
UnsubsampledNumberOfSamples	Integer	The total number of samples collected during data acquisition.
RequestedPostTriggerSeconds	Double	The exact number of seconds specified in the "Default post-trigger second(s)" field of a Test Setup. This may differ slightly from PostTriggerSeconds which reflects the amount of actual data recorded.
RequestedPreTriggerSeconds	Double	The exact number of seconds specified in the "Default pre-trigger second(s)" field of a Test Setup. This may differ slightly from PreTriggerSeconds which reflects the amount of actual data recorded.
PostTriggerSeconds	Double	The number of seconds of recorded data that the user requested after T=0.
PreTriggerSeconds	Double	The number of seconds of recorded data that the user requested before T=0.
RecordingMode	String	Options are RecorderMode, CircularBuffer, AutoRecorderMode, AutoCircularBufferMode, ContinuousRecorderMode, HybridRecorderMode and MultiHybridRecorderMode.
SampleRateHz	Integer	The rate at which sampling occurred during data collection
StartRecordSampleNumber	Integer	The sample number at which the start signal was first detected. The value will always be 0 when RecordingMode = CircularBuffer.
NumberOfChannels	Integer	The number of user configured channels within the module.

Name	Data Type	Description
InlineSerializedData	Boolean	
BaseSerialNumber	String	For TDAS modules installed in a rack, this is the rack's serial number. All other DAS use the unit's serial number.
StartRecordTimestampSec	Integer	
StartRecordTimestampNanoSec	Integer	
TriggerTimestampSec	Integer	
TriggerTimestampNanoSec	Integer	
PTPMasterSync	Boolean	

<TriggerSampleNumbers>

This is a list (possibly 0 length) of trigger sample numbers. In the Circular Buffer case, there will be one trigger sample number. In Recorder mode, the trigger is optional. In the case of multiple event mode, there may be more than one trigger sample number.

<Channels>

The Channels tag contains a list of channel elements. It should have the same number of entries as NumberOfChannels in the Module tag. The type of the child elements will depend on the type of channel.

<AnalogInputChannel>

The AnalogInputChannel tag is used for any DAS input channel (analog or digital). (Note: There is a typo in the tag name and “Chanel” is misspelled. It has been retained for backward compatibility). Many of the attributes indicate how the channel was configured during the test. The AnalogInputChannel element has the following properties:

Name	Data Type	Description
ChannelType	String	This identifies the representation of the data contained in the .BIN file. Currently this value is always expected to be DTS.Serialization.Test+Module+AnalogInputChannel.

Name	Data Type	Description
Number	Integer	The channel number within the DAS <module>. For SLICE Bridge, channels are numbered 0–2. For TDAS PRO SIM, channels are numbered 0-7. For TDAS PRO TOM, channels are numbered 0-7 where channel 0 is the voltage measurement for TOM external channel 1 and channel 1 is the current measurement for TOM external channel 1; channel 2 is the voltage measurement for TOM external channel 2 and channel 3 is the current measurement for TOM external channel 2, etc. For SLICE PRO SIM, channels are numbered 0-2 for each module. For TDAS G5 DAS, channels are numbered 0-7 for each module.
DigitalMultiplier	String	Used for digital input channels only. The channel's form of multiplier (currently only ArbitraryLowAndHigh), the low value (typically 0) and the high value (typically 1).
DigitalMode	String	Used for digital input channels only. CCNO = Contact Closure Normally Open (the default for digital inputs and the only mode that TDAS G5 DAS support) CCNC = Contact Closure Normally Closed TLH = Transition Low to High THL = Transition High to Low
Start	Date	Currently unused.
Bridge	String	Either FullBridge or HalfBridge.
BridgeResistanceOhms	Integer	The specified bridge resistance used during the shunt check.
ZeroPoint		
ChannelDescriptionString	String	The user-provided description for the channel.
ChannelName2	String	For channels created in ISO mode, the name of the channel from the Group Template. For channels created in non-ISO mode, the name of the sensor used to create the channel.
ChannelId	String	An internal representation of the channel based on its Group name and position in the hardware.

Name	Data Type	Description
HardwareChannelName	String	For SLICE Bridge = [<BR sn>] CH-01 through 03 For TDAS PRO SIM = [<SIM sn>] CH-01 through 08 For TDAS PRO TOM = [<TOM sn>] SQ-01 through 04 TOM digital outputs = [<TOM sn>] DO-01 through 08 For TDAS PRO DIM = [<DIM sn>] DI-01 through 16 For TDAS G5 DAS = [<G5 sn>] CH-01 through 32 G5 DAS digital inputs = [<G5 sn>] DI-01 through 16 For SLICE PRO SIMs = [<SPS sn>] CH-01 through 18] For SLICE PRO TOM = [<SPT sn>] SQ-01 through 04 TOM digital outputs = [<SPT sn>] DO-01 through 08 For SLICE PRO DIM = [<SPD sn>] DI-01 through 18
Description	String	The user-provided description for the sensor; currently the same as ChannelDescriptionString.
DesiredRange	Integer	The user-requested full scale.
Sensitivity	Double	The sensitivity of the sensor in either mv/V/EU or mv/EU depending on ProportionalToExcitation.
SoftwareFilter	String	The requested filtering to apply to this channel. Stored data is unfiltered and this value must be used to apply proper filtering. Typical values are "1650hz" for CFC1000.
ProportionalToExcitation	Boolean	Indicates if the output of this sensor is proportional to excitation. Used in conjunction with Sensitivity.
IsInverted	Boolean	<i>(Optional)</i> Indicates if the data should be inverted before presenting to the user. If missing, this attribute is considered 'false'.
LinearizationFormula	String	The formula used to generate a graph of data collected using a non-linear sensor.
IsSubsampled	Boolean	<i>(Optional)</i> Indicates if the data stored on disk is at a lower sample rate than the original data collection. If missing, this attribute is considered 'false'.
AbsoluteDisplayOrder	Integer	The nominal ordering of channels in reports, graphs and exports.
LastCalibrationDate	Date	The most recent date that a sensor was calibrated.
SensorID	String	A sensor's electronic ID.
OffsetToleranceLowMv	Double	The most that a sensor's offset is allowed to vary below 0 mV and still pass a diagnostic offset check.

Name	Data Type	Description
OffsetToleranceHighMv	Double	The most that a sensor's offset is allowed to vary above 0 mV and still pass a diagnostic offset check.
DataFlag	Boolean	A value that can be assigned to a channel when viewing data. Possible values are "0" (None), "1" (Normal), "2" (Saturated), "3" (ZeroCrossing), "4" (BrokenWire) and "5" (Other).
ExcitationVoltage	String	The voltage specified in a sensor's definition.
Eu	String	The user provided Engineering Units (EU) (e.g., mm, g, or msec ²).
SerialNumber	String	The serial number of the sensor used with this channel.
CalSignalEnabled	Boolean	Applies to SLICE IEPE only.
ShuntEnabled	Boolean	For SLICE Bridge only. Indicates if the user requested the channel be shunted during diagnostics.
VoltageInsertionCheckEnabled	Boolean	True = check enabled or False = no check performed.
RemoveOffset	Boolean	Indicates if the user requested hardware offset compensation be used during diagnostics.
ZeroMethod	String	Identifies the type of software offset compensation that should be used. If the value is "UsePreCalZero," then the Pre-Calibration zero value stored in the channel file should be used. If the value is "AverageOverTime," then an average value computed from the channel data should be used.
ZeroAverageWindowBegin	Double	If ZeroMethod = AverageOverTime, this is the beginning of the window to be used for computing the average.
ZeroAverageWindowEnd	Double	If ZeroMethod = AverageOverTime, this is the end of the window to be used for computing the average.
InitialEu	Double	A value provided by the user that should be subtracted from all scaled data in addition to the selected ZeroMethod.
InitialOffset	Double	A sensor's offset when last calibrated.
UnsubsampledSampleRateHz	Integer	The sampling rate used during data collection. Valid only if IsSubsampled = True.
MeasuredExcitationVoltage	Double	<i>(Optional)</i> The measured excitation voltage, if available. Used by DataPRO for scaling proportional-to-excitation sensor data if "factory" excitation voltage is not available.

Name	Data Type	Description
FactoryExcitationVoltage	Double	<i>(Optional)</i> The factory excitation voltage, if available. Used by DataPRO for scaling proportional-to-excitation sensor data.
TimeOfFirstSample	Double	The time relative to T=0 of the first sample.
Multiplier		
UserOffsetEU		
UnitConversion	Double	The factor used to calculate displayed EU given a sensor's sensitivity and desired range.
AtCapacity	Boolean	Whether or not a sensor was calibrated based on its maximum output.
CapacityOutputIsBasedOn	Double	If AtCapacity = True, the sensor's output that calibration was based on.
SensitivityUnits	String	The units that a sensor's sensitivity is based on; either "NONE", "mV", "mvPerV" (mv/V), "mvPerVperEU" (mV/V/EU), or "mvPerEU" (mV/EU).
SensorCapacity		
ChannelGroupName		
MeasuredShuntDeflectionMv	Double	<i>(Optional)</i> If a shunt test was performed, the actual deflection of the shunt.
TargetShuntDeflectionMv	Double	<i>(Optional)</i> If a shunt test was performed, the expected shunt deflection.
MeasuredCalSignalMv	Double	Diagnostic results from calibration signal used to determine gain (IEPE 1.0 only).
TargetCalSignalMv	Double	Diagnostic results from calibration signal used to determine gain (IEPE 1.0 only).

Appendix G: DataPRO Binary File Format

Bin File Header Version 4*

Offset	# of bytes	Data Type	Description
0	4	UInt32	Magic key to identify file: 0x2C36351F
4	4	UInt32	Version number of this file header*
8	8	UInt64	Offset (in bytes) from start of file to where data samples start
16	8	UInt64	Number of samples in this file
24	4	UInt32	Number of bits per sample
28	4	UInt32	0 = unsigned samples; 1 = signed samples
32	8	Double	Sample rate
40	2	UInt16	Number of triggers (may be 0)
42	N = number of triggers * 8	UInt64	Trigger sample number
N + 42	4	Int32	Pre-test zero level (in counts)
N + 46	4	Int32	Removed ADC (in counts)
N + 50	4	Int32	Pre-test diagnostics level (in counts)
N + 54	8	Double	Pre-test noise (percentage of full scale)
N + 62	4	Int32	Post-test zero level (in counts)
N + 66	4	Int32	Post-test diagnostics Level (in counts)
N + 70	4	Int32	Data zero level (in counts)
N + 74	8	Double	Scale factor mV (mV/Count)
N + 82	8	Double	Scale factor EU (mV/EU or mV/V/EU)
N + 90	2	Int16	EU field length (with terminator)
N + 92	X = length of EU field	Char	Engineering units (without NULL termination)

Offset	# of bytes	Data Type	Description
N + 92 + X	8	Double	Excitation
N + 100 + X	4	Int32	Trigger adjustment samples (reserved)
N + 104 + X	4	Int32	Zero mV (in counts)
N + 108 + X	4	Int32	Window average (in counts)
N + 112 + X	4	Int32	Original offset (in counts)
N + 116 + X	16	Char []	ISO code
N + 132 + X	4	Int32	CRC16 for binary header information from byte 0 to (N + 132 + X - 1)
N + X + 136 64bit (ulong) offset found in 3rd file field	Size of sample data	16-, 24-, or 32- bit depending on "Number of bits per sample"	DATA SAMPLES START HERE

Appendix H: SQL Server Setup

This section shows the configuration of SQL Server 2014 on Windows 10. Please refer to the [PC Requirements](#) section (page 8) for information on supported versions. Installation on Windows 11 may require additional configuration as outlined in the [Windows 11 Support](#) section below.

SQL Server Express Installation

1. Launch the SQL Server Express setup, SQLEXP_x64_ENU.exe:

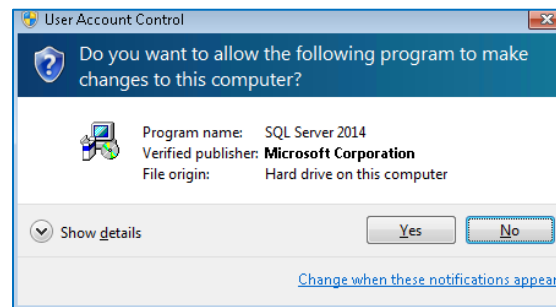

2. Select "Run":

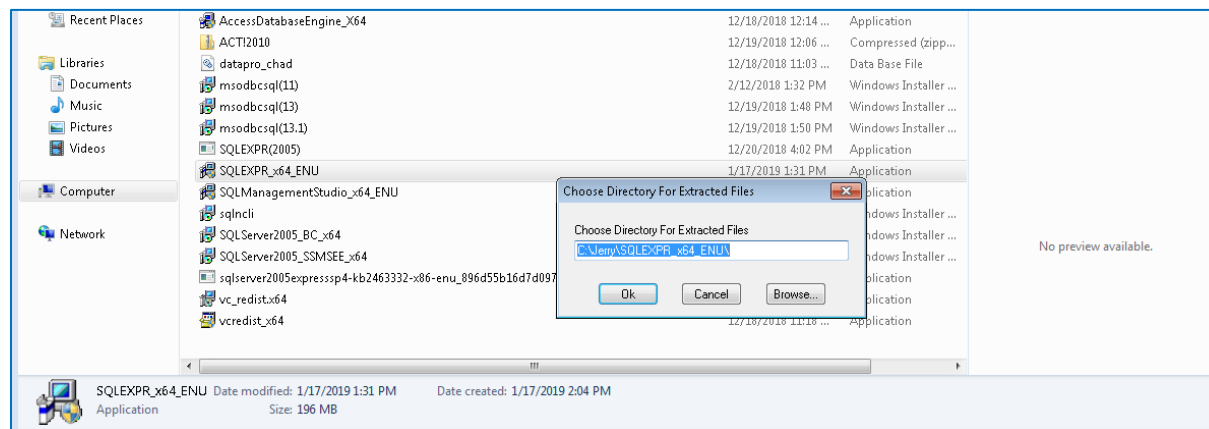

3. Click OK.

4. Wait...

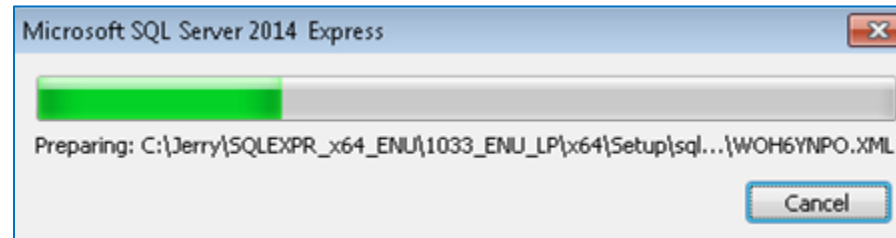

5. Click “New SQL Server stand-alone installation or add features to an existing installation”:

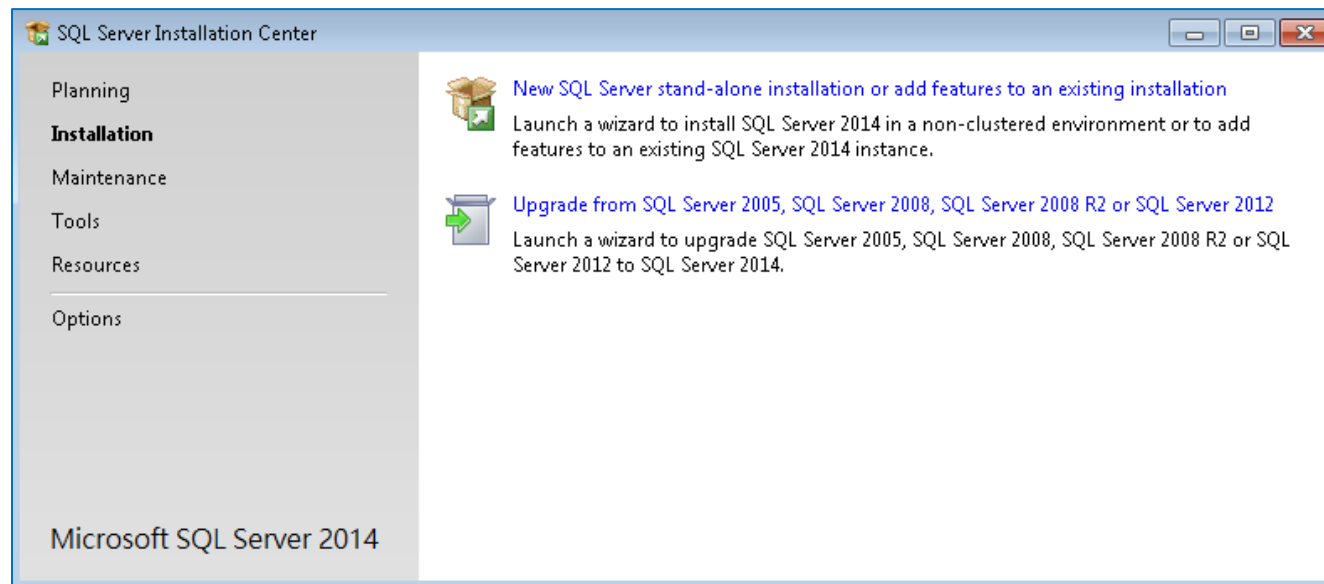

6. Wait...



7. Click "Next":

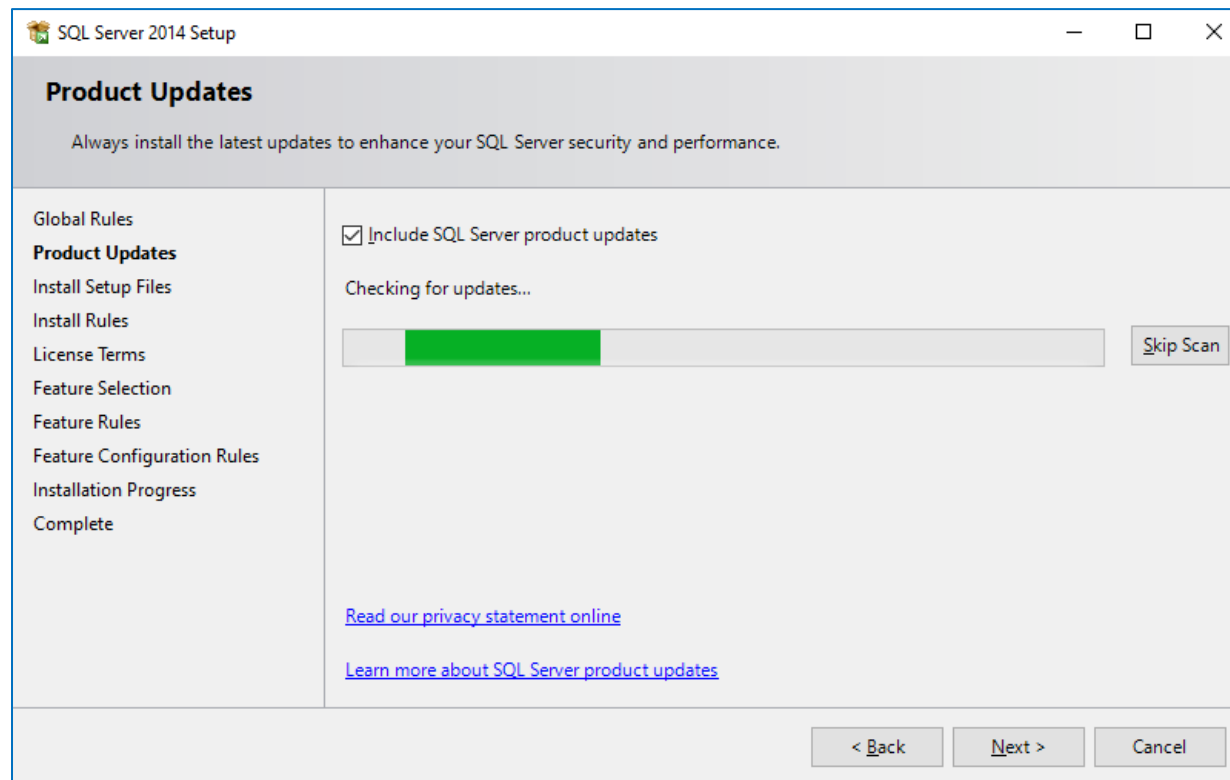

8. Click "Next":

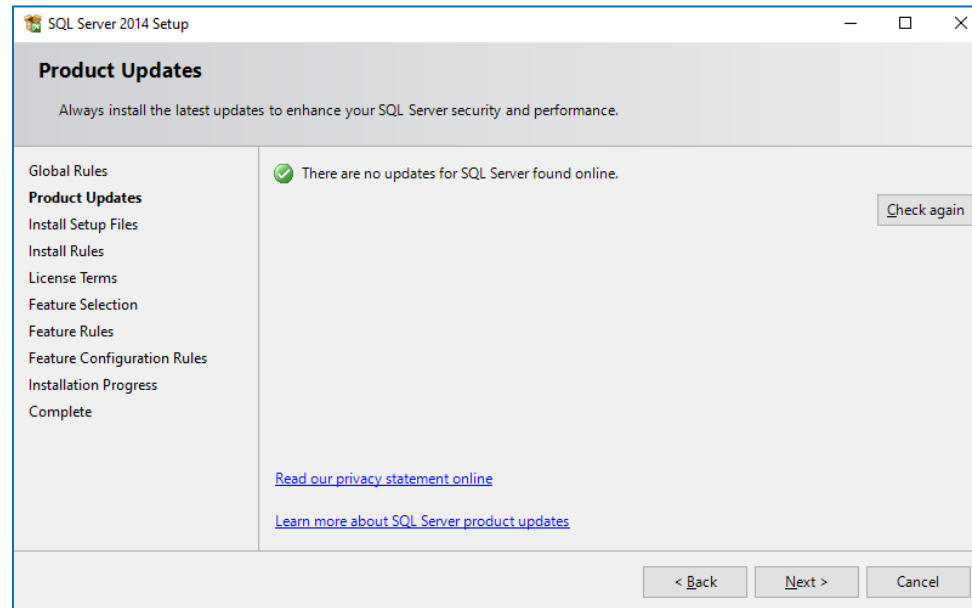

9. Wait...

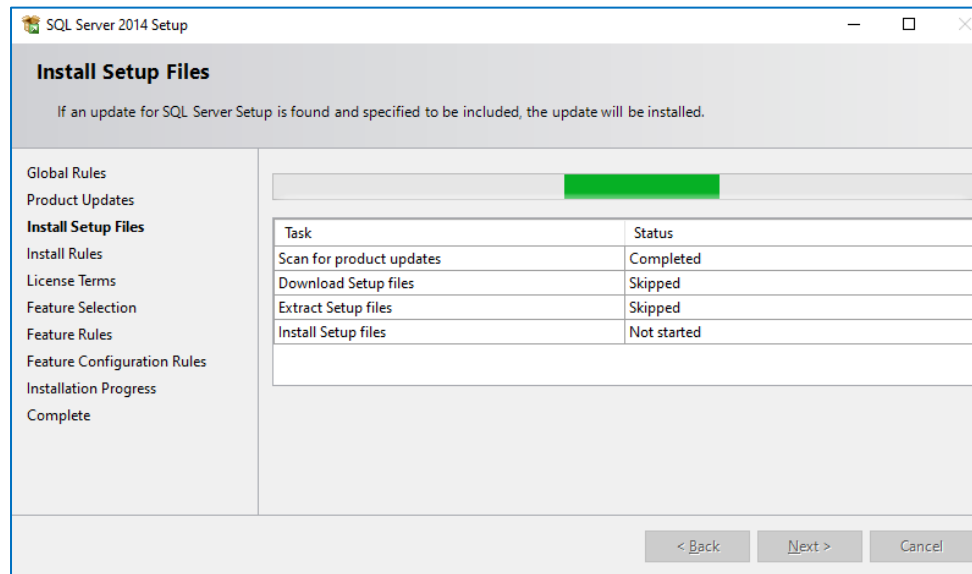

10. Check the “I accept the license terms” box, then click “Next”:

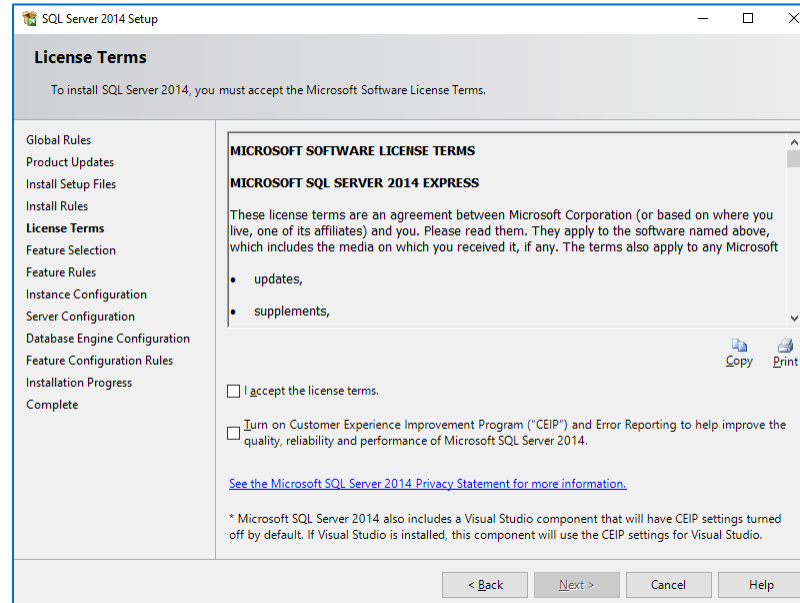

11. Click “Next”:

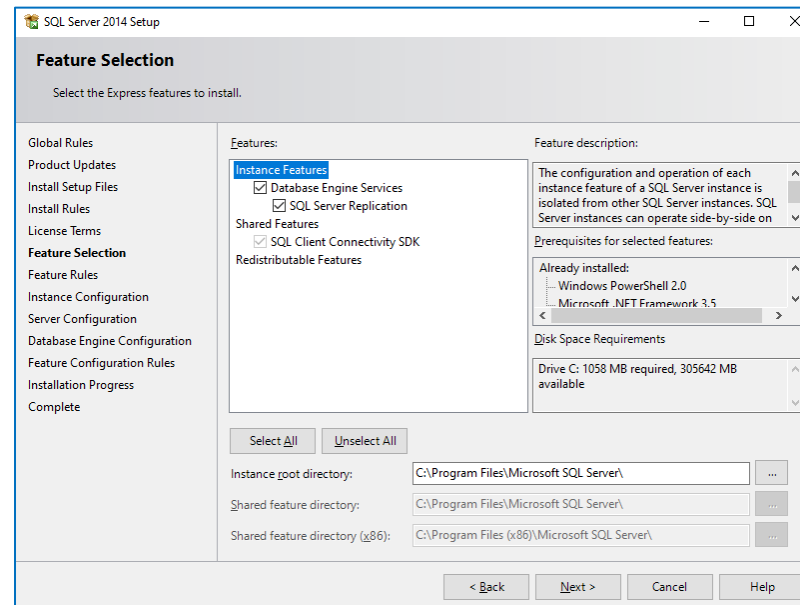

12. Click “Next”:

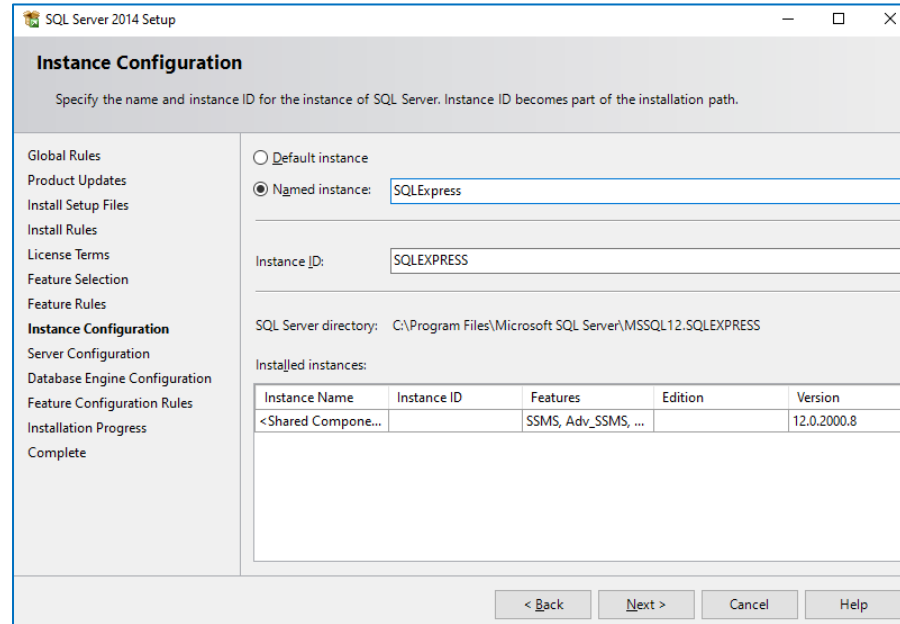

13. Click “Next”:

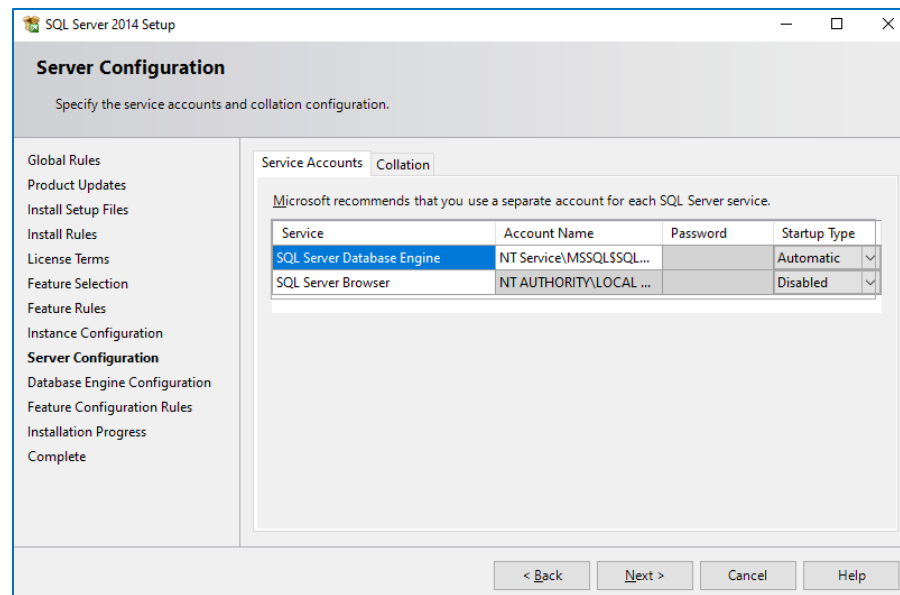

14. Click “Next”:

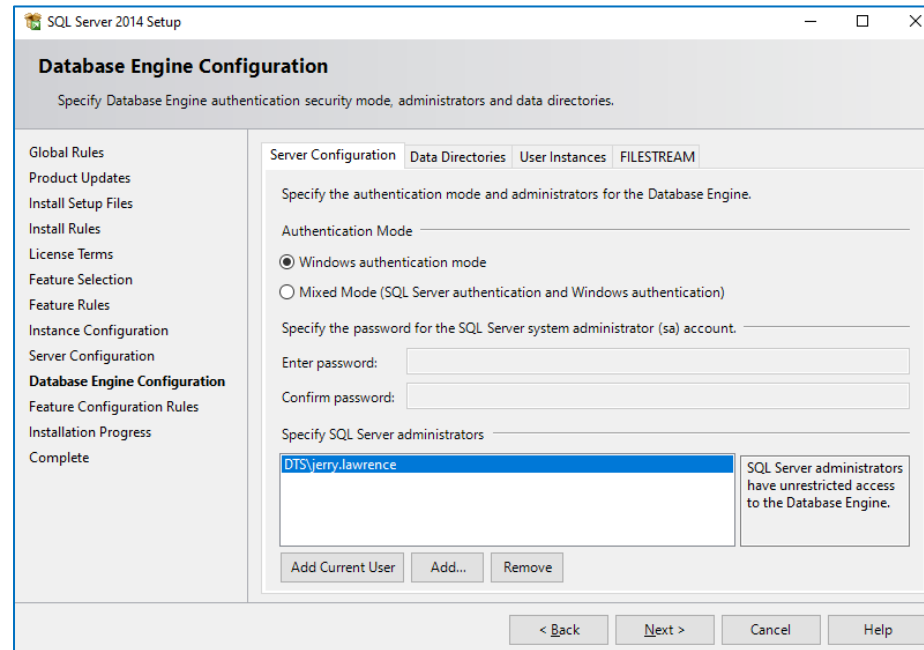

15. Wait...

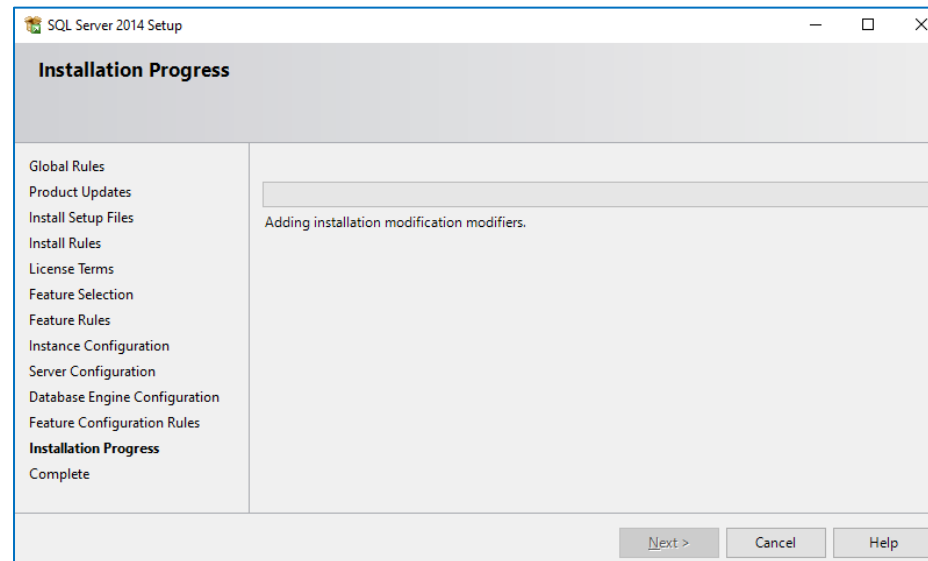

16. Keep waiting...

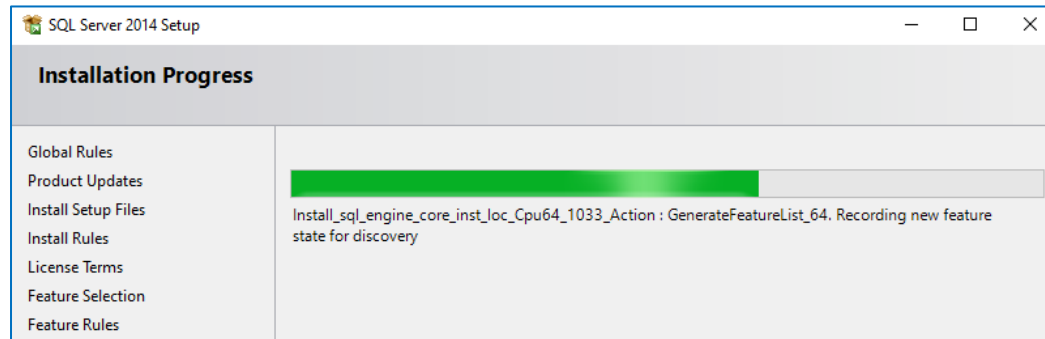

17. Click "Close":

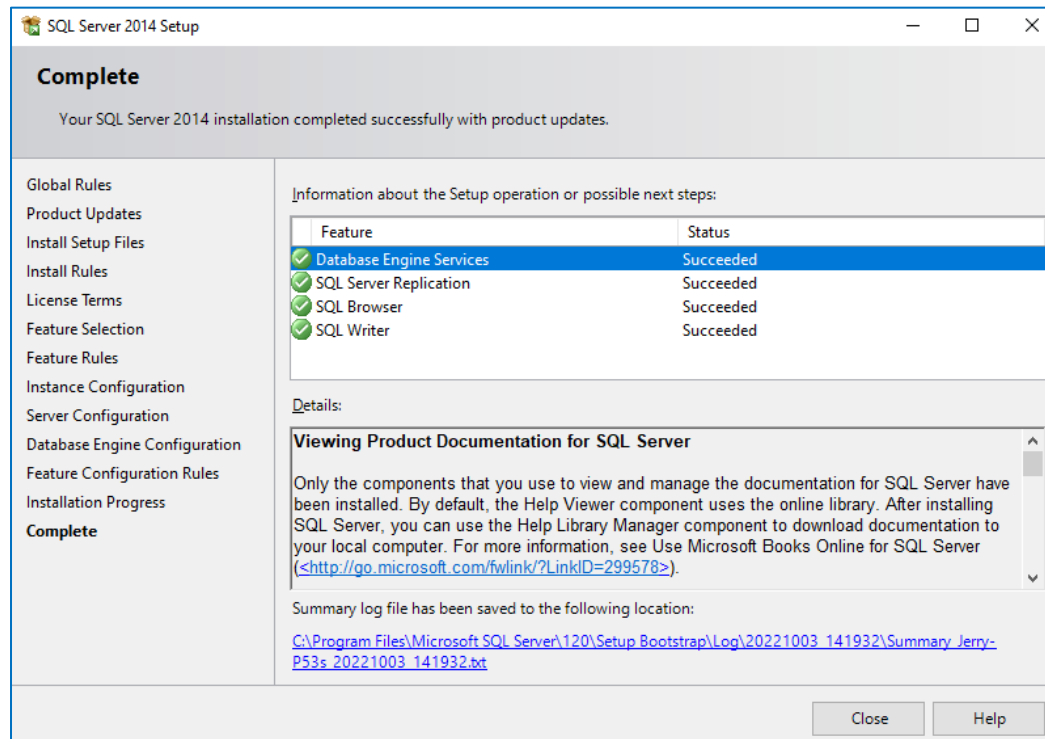

Windows 11 Support

SQL Server may fail to operate normally on Windows 11 due to a lack of support for disk sector sizes greater than 4 KB. Information about this issue can be found on Microsoft Learn:

[Troubleshooting operating system disk sector size greater than 4 KB - SQL Server | Microsoft Learn](#)

As a workaround, a registry key can be set to force the sector size to be emulated as 4 KB. This may be done either before or after installation of DataPro. Choose one of the following options:

Option 1 - Using PowerShell as an administrator:

```
New-ItemProperty -Path "HKLM:\SYSTEM\CurrentControlSet\Services\stornvme\Parameters\Device" -Name  
"ForcedPhysicalSectorSizeInBytes" -PropertyType MultiString -Force -Value "* 4095"
```

Option 2 - Manually via Registry Editor:

1. Navigate to

Computer\HKEY_LOCAL_MACHINE\SYSTEM\CurrentControlSet\Services\stornvme\Parameters\Device.

2. On the Edit menu, go to New -> Multi-String Value. Name it ForcedPhysicalSectorSizeInBytes.

3. Modify the new value, setting it to * 4095

4. Select OK and close the registry editor.

After setting the registry key using either method, reboot to apply the change.

SQL Server Management Studio Installation

18. Install SQL Server Management Studio 2014 by running SQLManagementStudio_x64_ENU.exe:

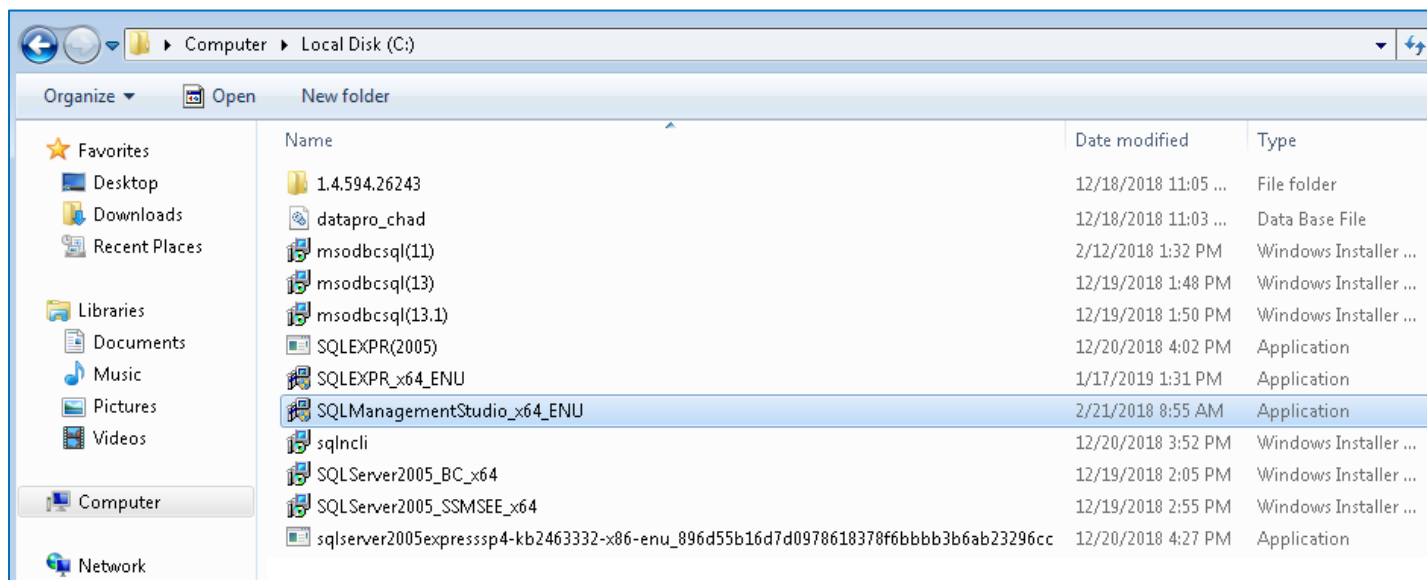

19. Click “Yes”:

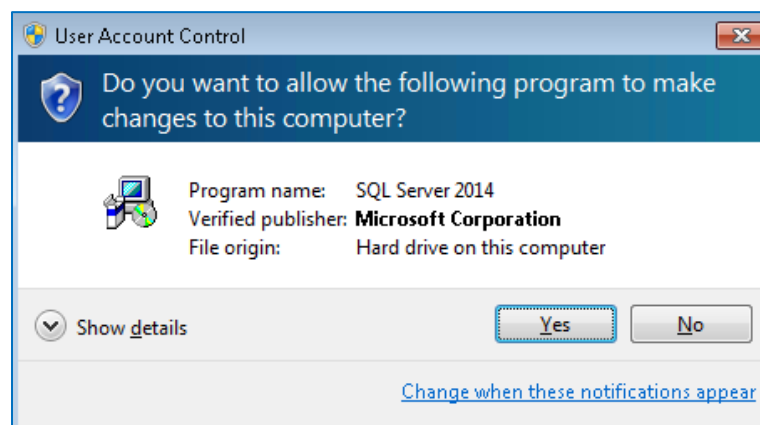

20. Modify the path if desired, then click “OK”:

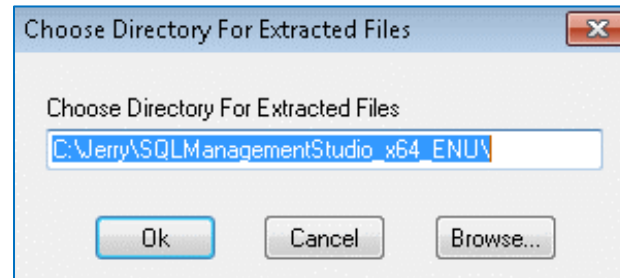

21. Wait...

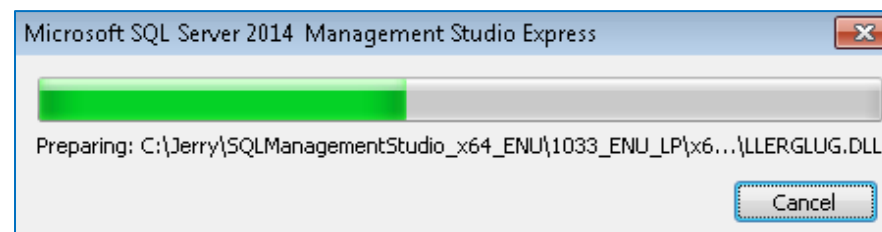

22. Click “New SQL Server stand-alone installation or add features to an existing installation”:

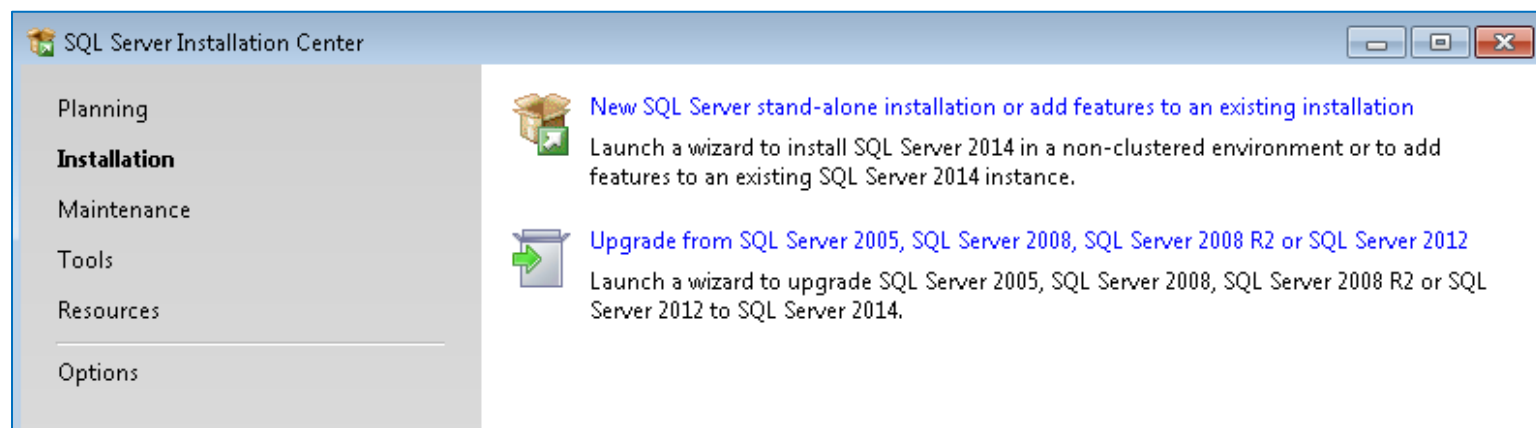

23. Change selection to “Add features to an existing instance of SQL Server 2014”, then click “Next”:

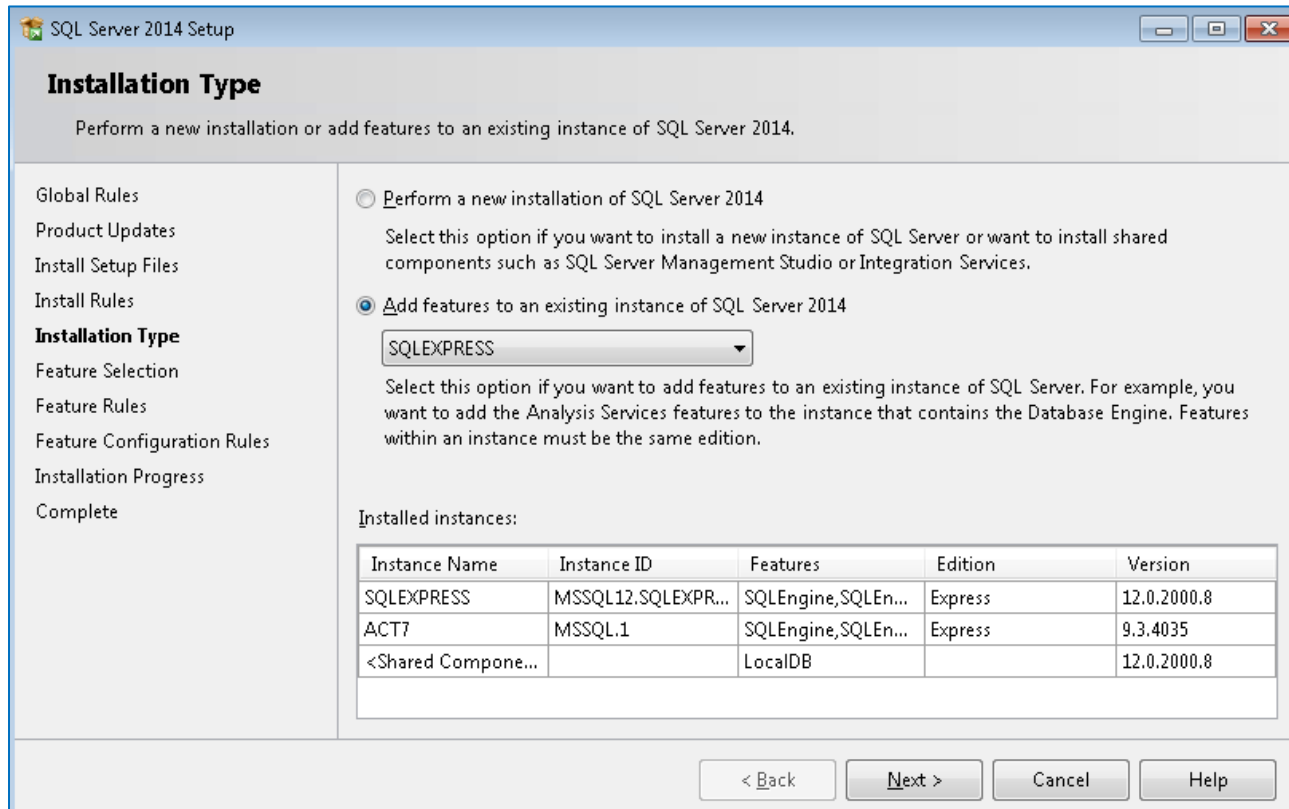

24. Check the “Management Tools – Basic” and “Management Tools – Complete” boxes, then click “Next”:

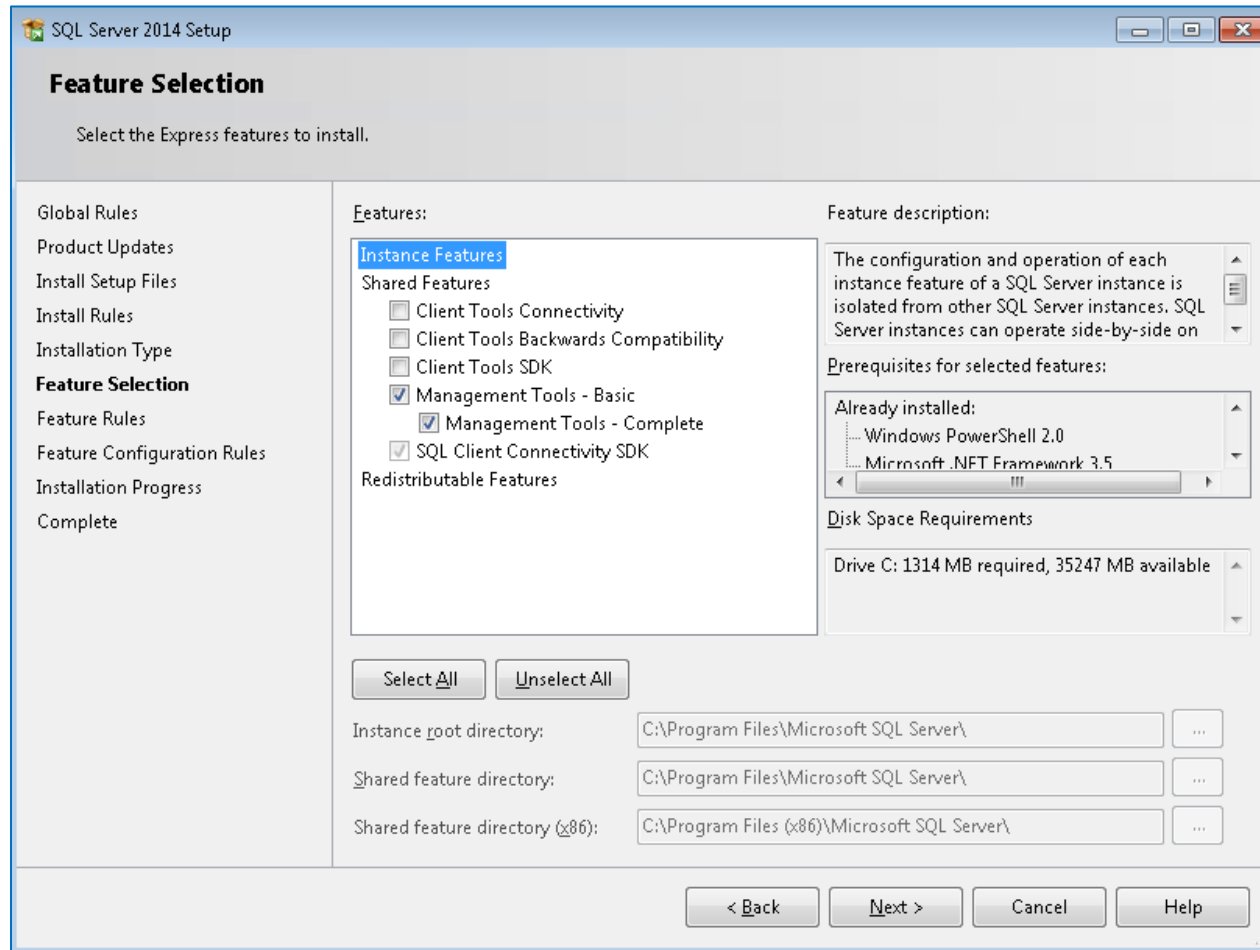

25. Wait...

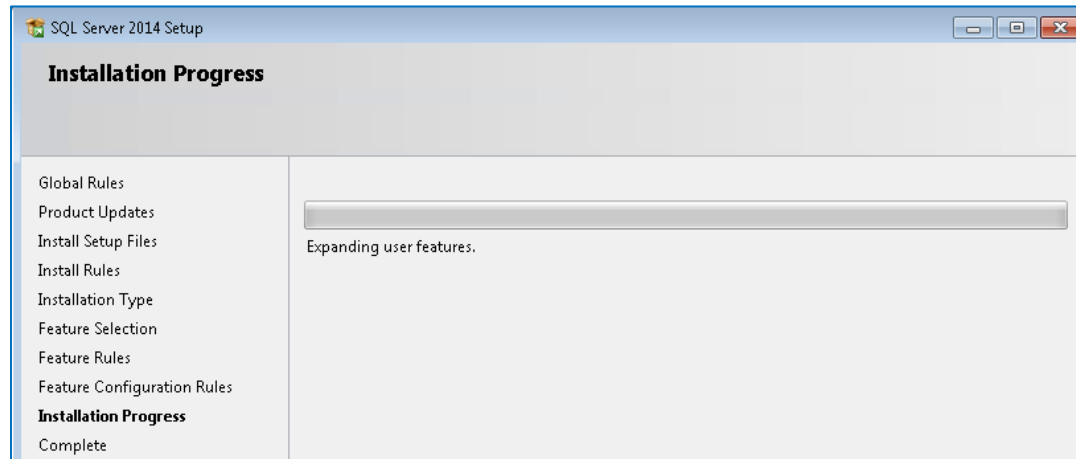

26. Click "Close".

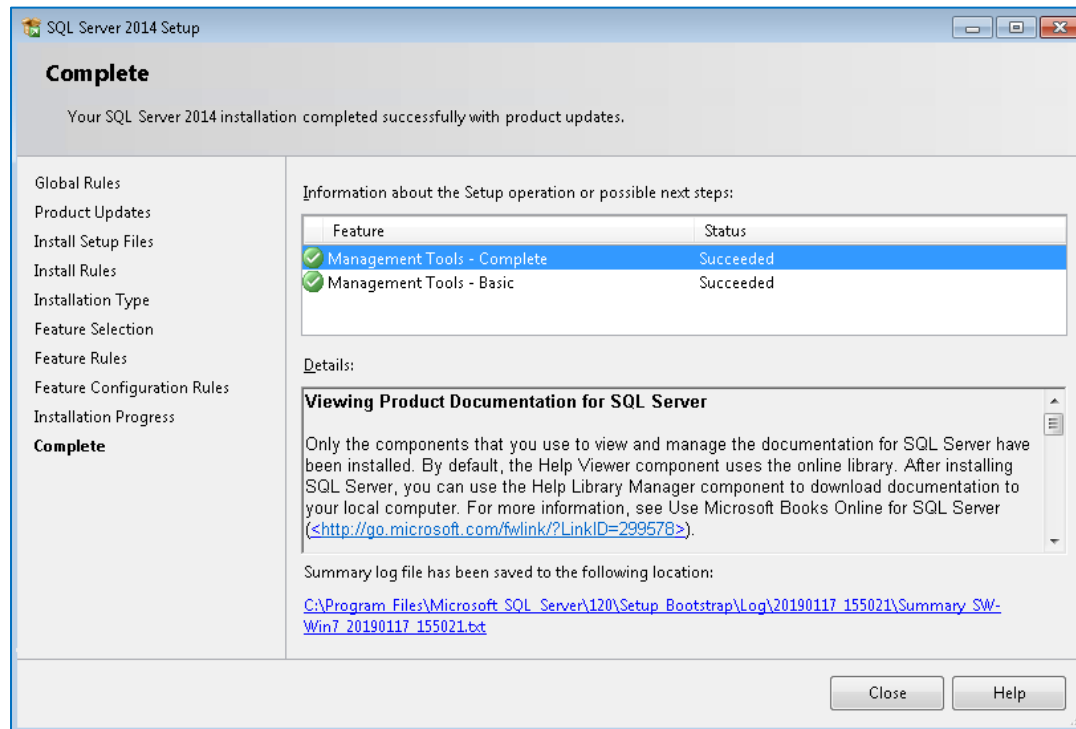

Firewall Configuration

27. Go to Control Panel | System and Security:

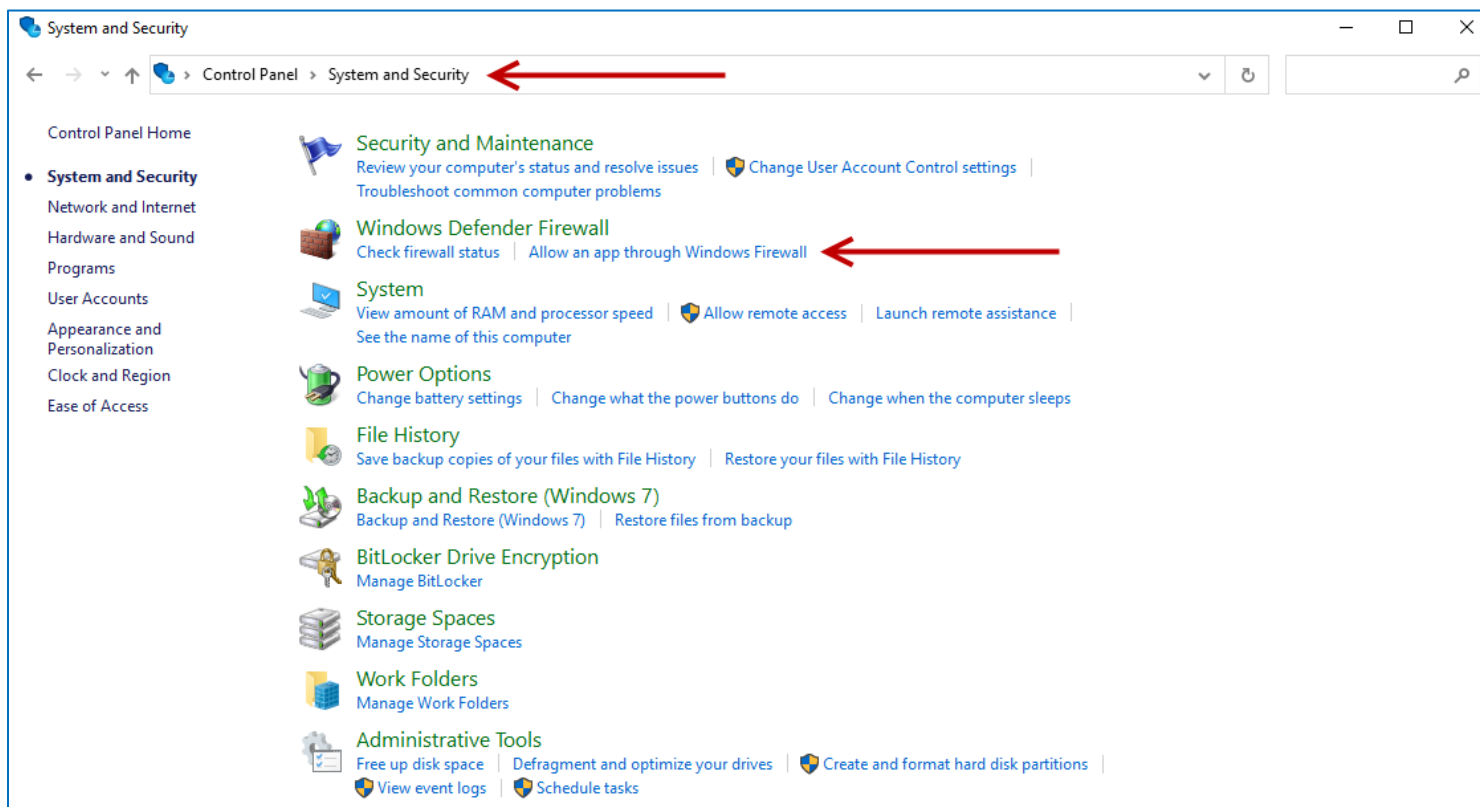

28. Click on “Allow an app through Windows Firewall”.

29. Click on “Change settings”, then click on “Allow another app...”:

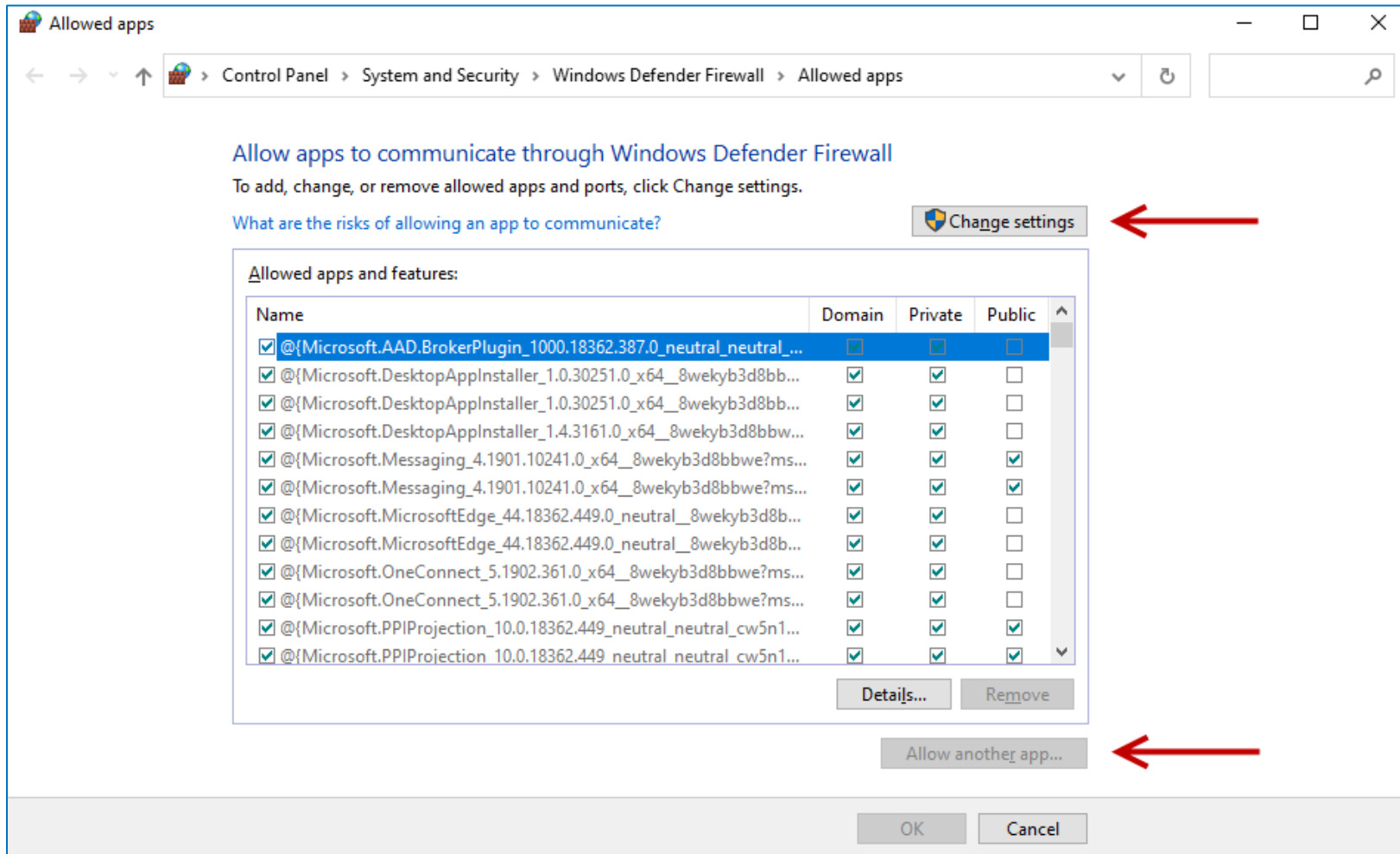

30. Click on “Browse...”, then browse to *C:\Program Files\Microsoft SQL Server\MSSQL12.SQLEXPRESS\MSSQL\Binn\sqlservr*, then click “Open”:

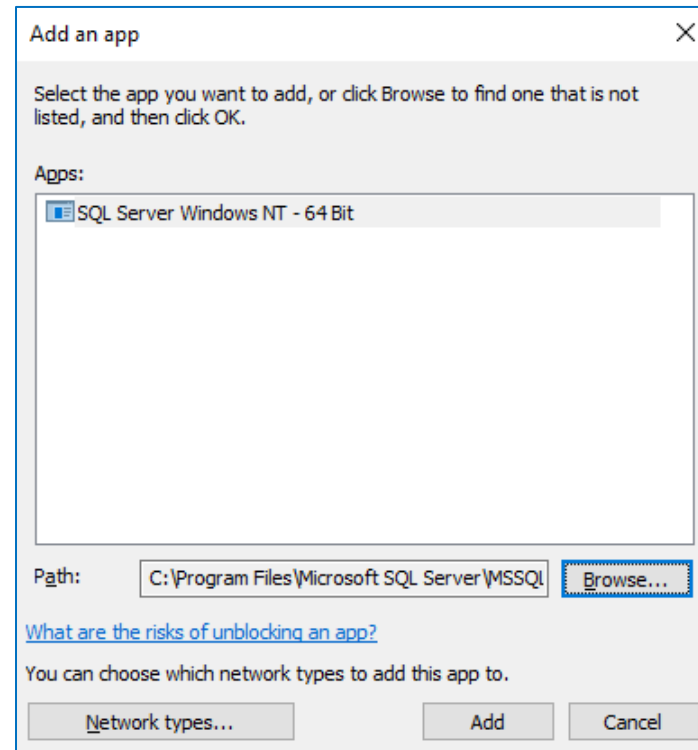

31. Click “Add”.
32. Click “OK”, then close the “System and Security” window.

SQL Server Configuration Manager

33. Run the SQL Server Configuration Manager application that was installed previously. Click “Yes” to let the program through the firewall:

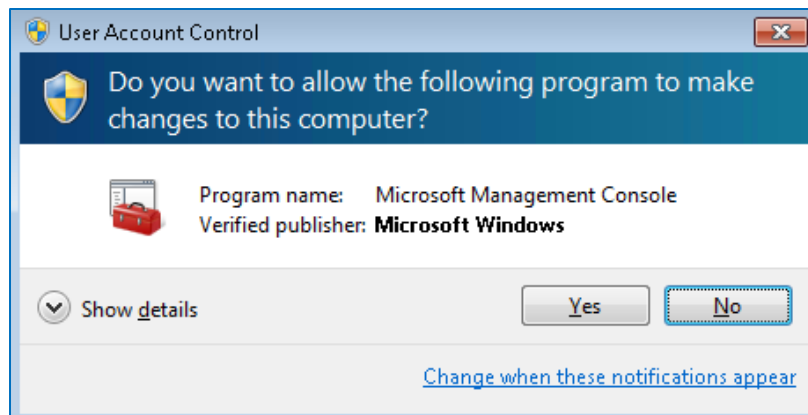

34. Expand “SQL Server Network Configuration”, select “Protocols for SQLEXPRESS”, right-click on “TCP/IP” and select “Enable”:

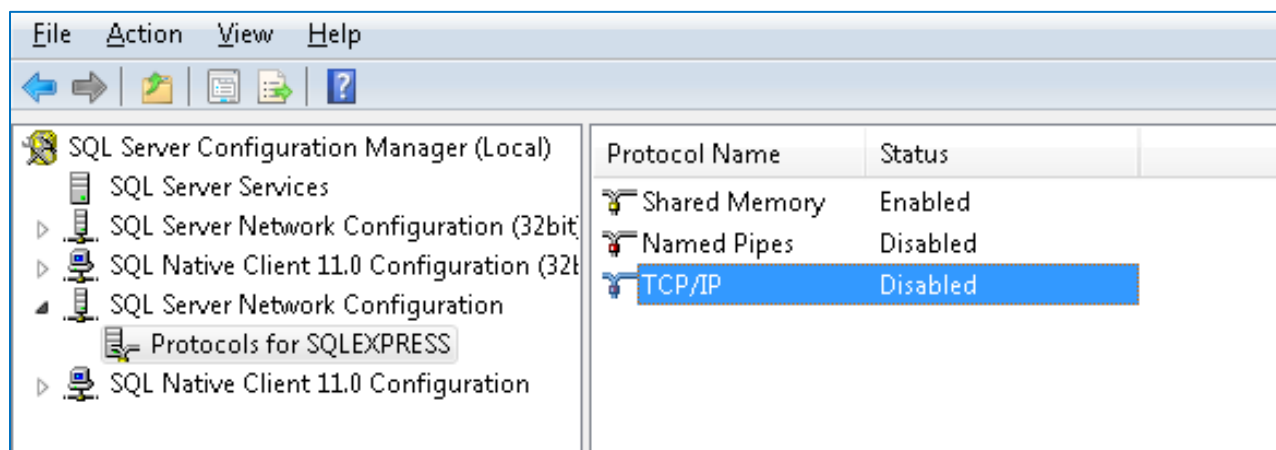

35. Click “OK”:

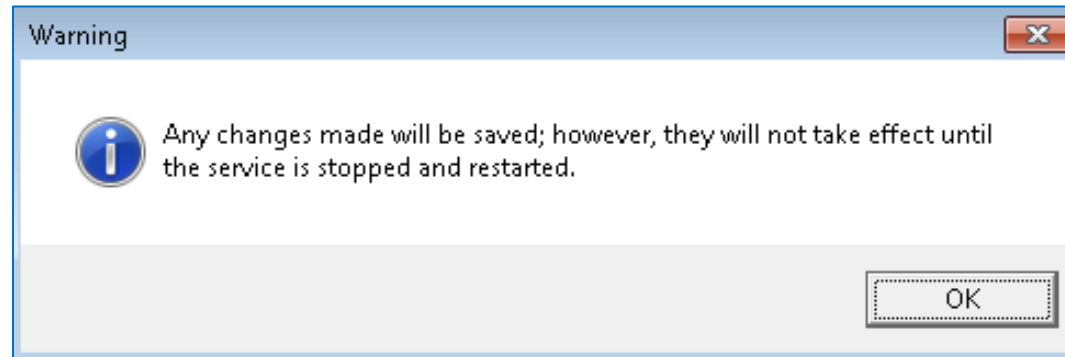

36. Double-click on the “TCP/IP” Protocol Name:

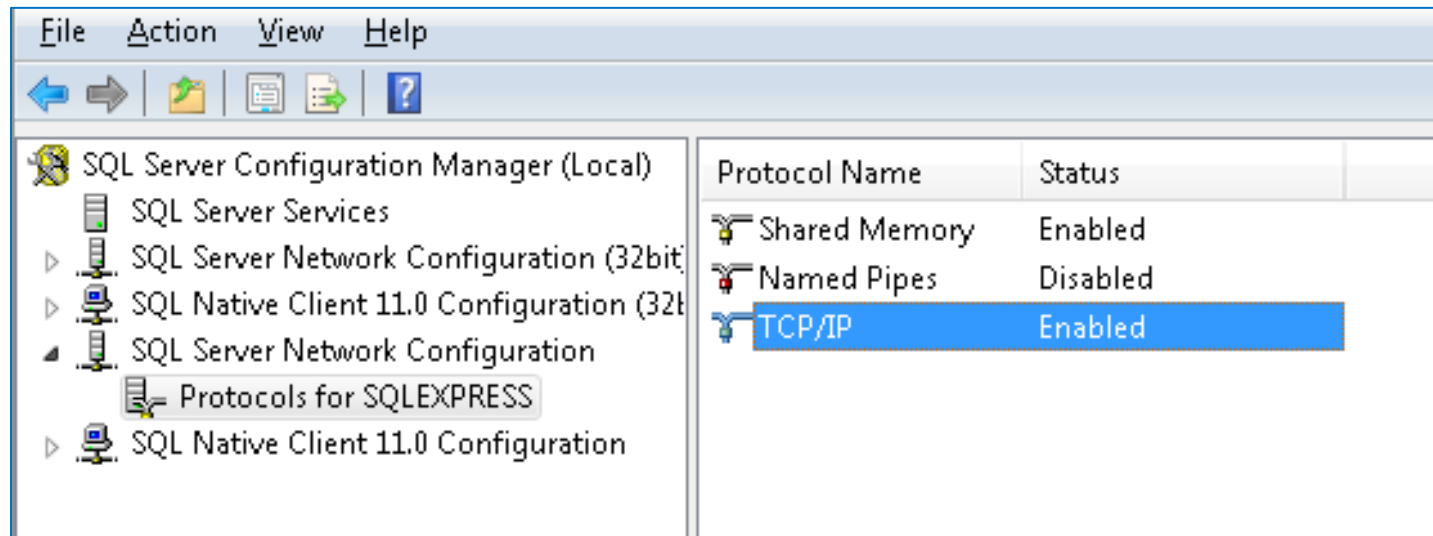

37. Select the “IP Addresses” tab, scroll to the bottom, blank out the “TCP Dynamic Ports” value and add “1433” as the “TCP Port” value under “IP All”:

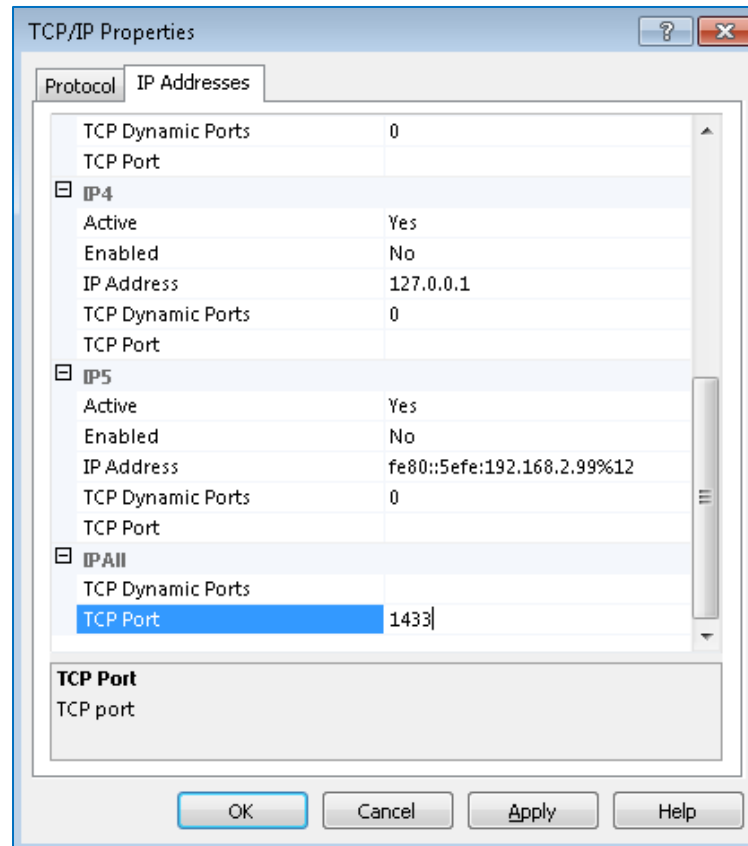

38. Click “OK”:

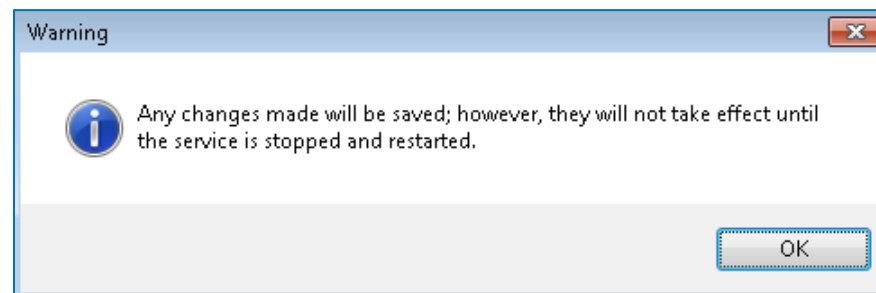

SQL Server Management Studio

39. Run the SQL Server Management Studio application.

40. Set “Server name” to “<your host name>\SQLEXPRESS”, then click “Connect”:

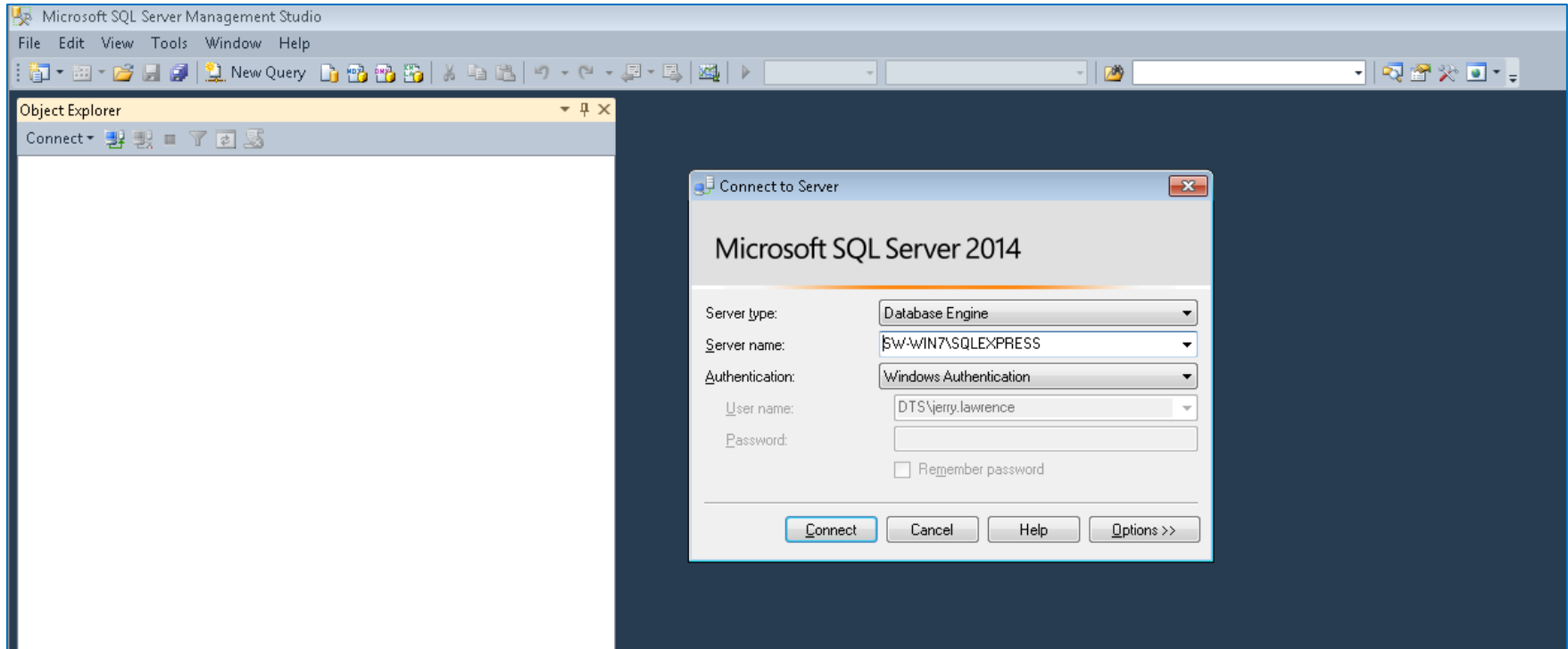

41. Right-click on the top-most level of the tree and select “Properties”. On the “Security” page, select “SQL Server and Windows Authentication mode” then click “OK”:

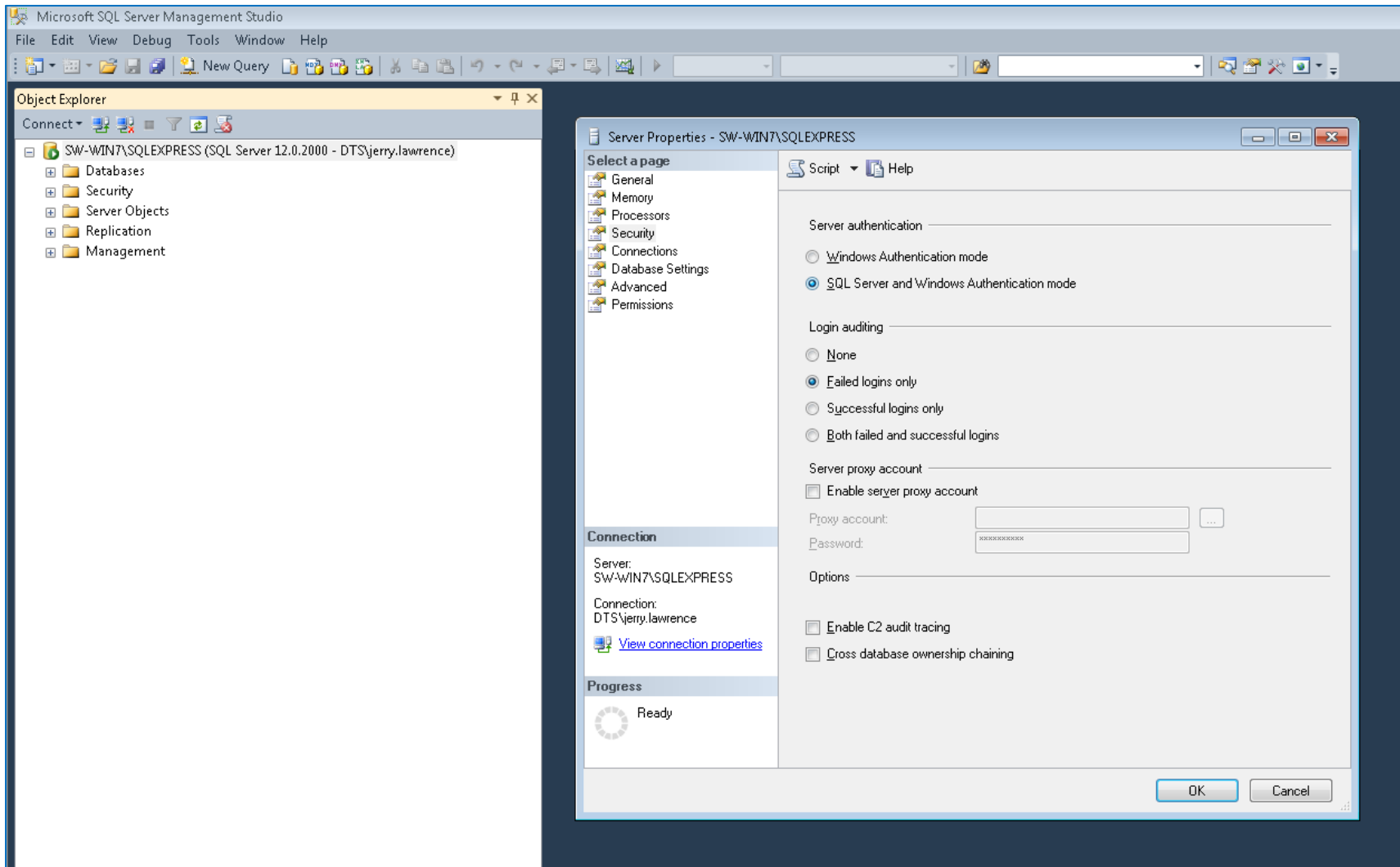

42. Click “OK”:

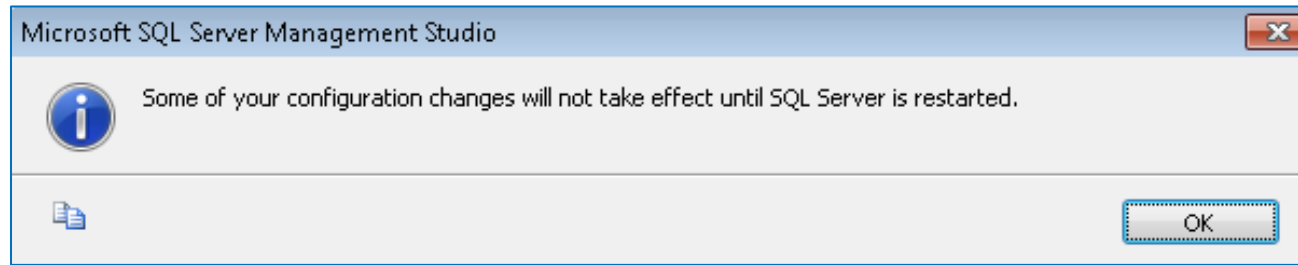

43. Go back to SQL Server Configuration Manager, select “SQL Server Services”, right-click on “SQL Server (SQLEXPRESS)” then click “Restart”:

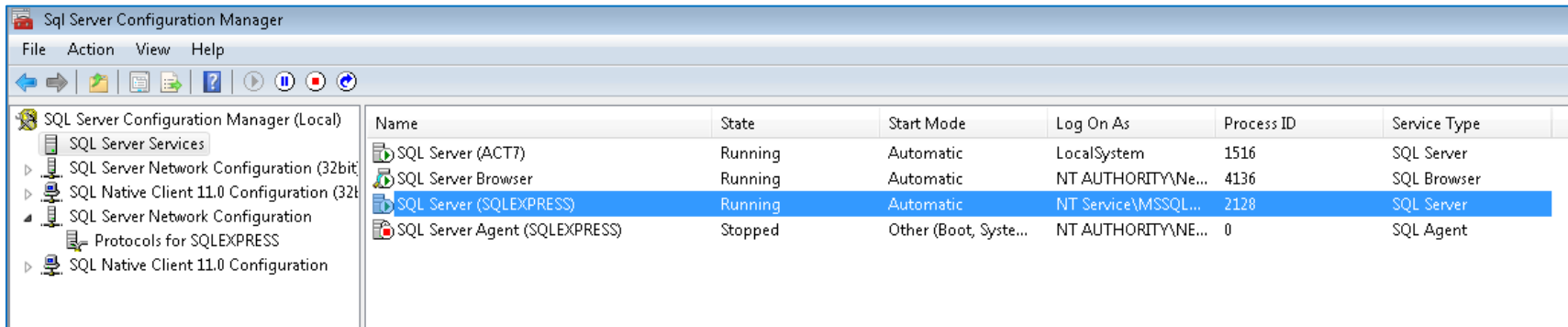

44. Wait...

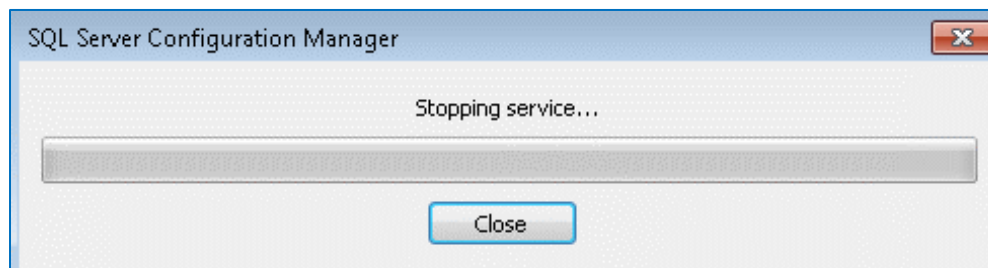

45. Go back to SQL Server Management Studio, right-click on Security | Logins and select “New Login...”:

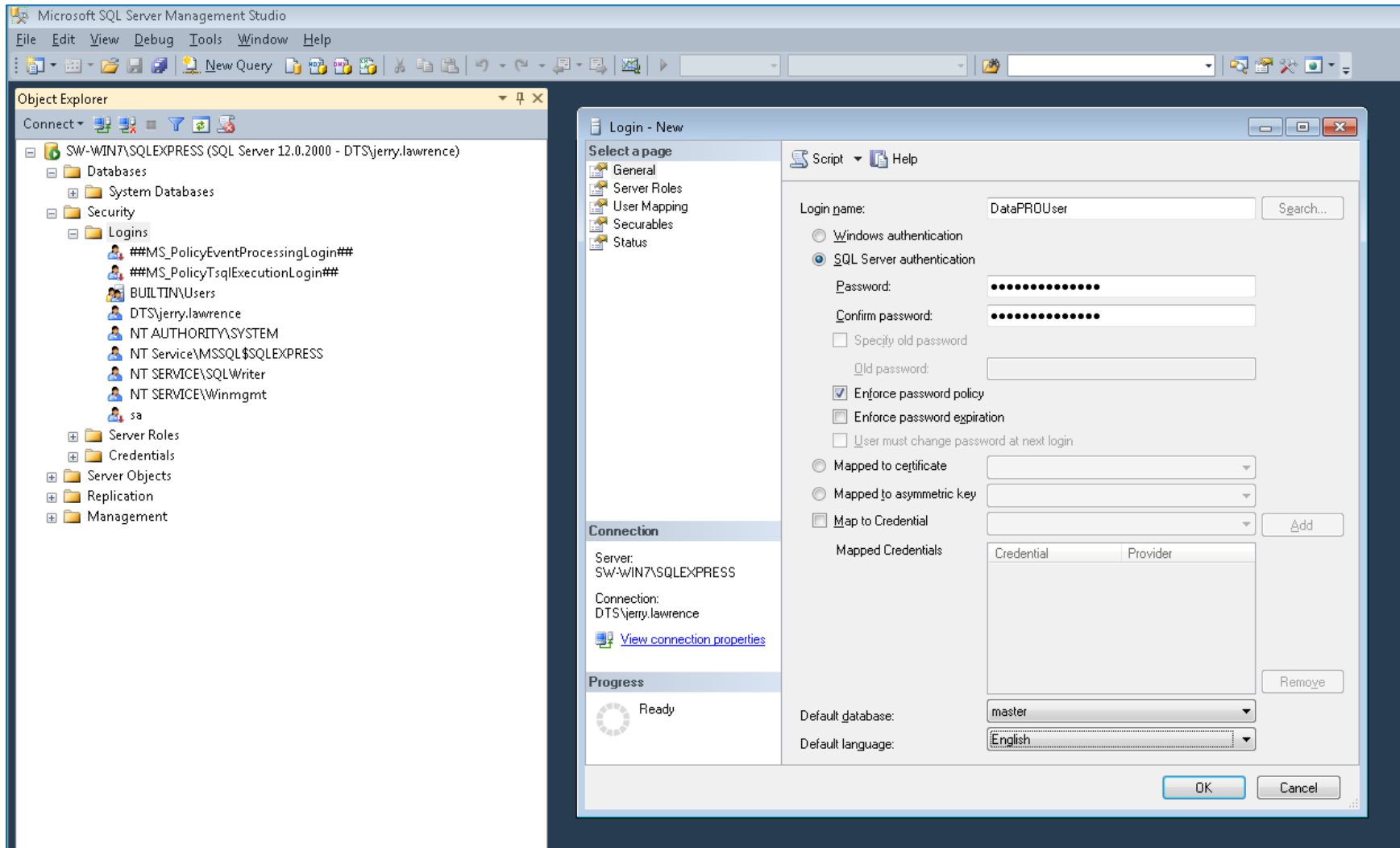

46. Enter “DataPROUser” in the “Login name” field, select “SQL Server authentication”, enter “DTSSealBeachHQ!” in the “Password” and “Confirm password” fields (this is arbitrary and can be changed to match the contents of the “LocalDBPassword” setting in the “DataPRO.exe.config” file that is installed as part of the DataPRO installation), then click “OK”.

47. Click “New Query” to open a query window, enter “EXEC sp_configure 'clr enabled', 1; RECONFIGURE WITH OVERRIDE” and click “! Execute”:

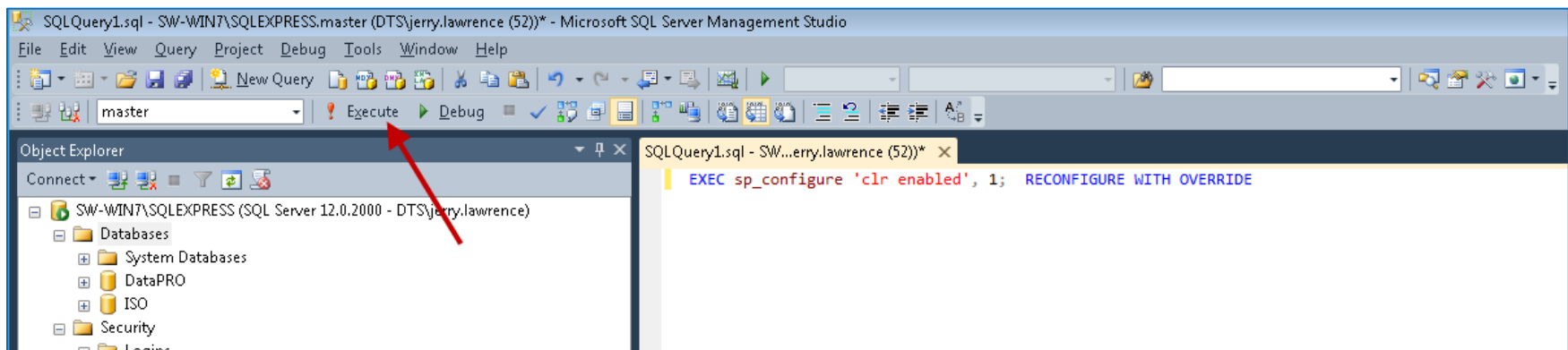
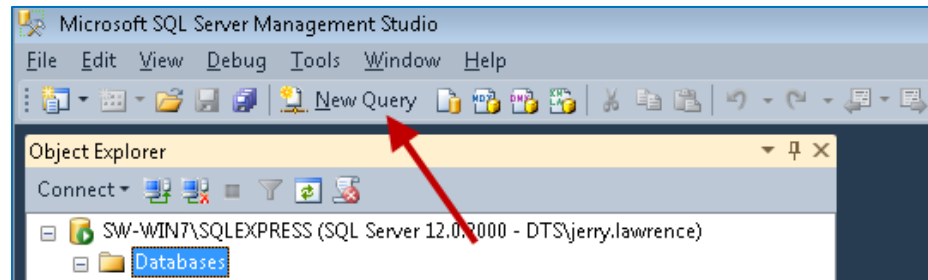

48. Note the successful response:

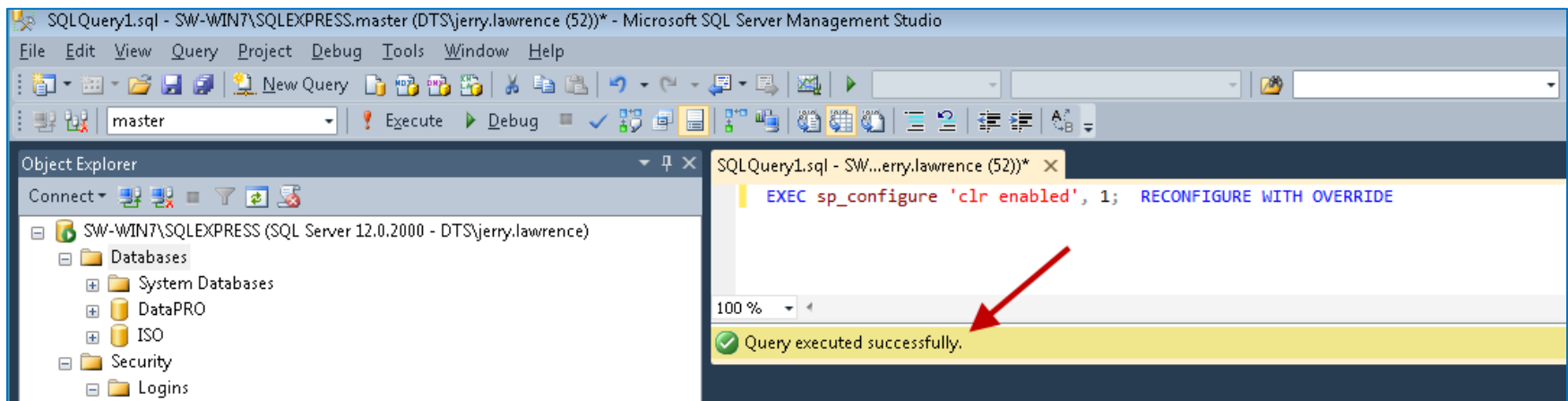

Connecting to the DataPRO Database

49. After DataPRO has been installed on a client system, copy the “DataPRO.mdf”, “DataPRO_log.ldf”, “ISO.mdf” and “ISO_log.ldf” files to the server, then right-click “Databases” and select “Attach...”:

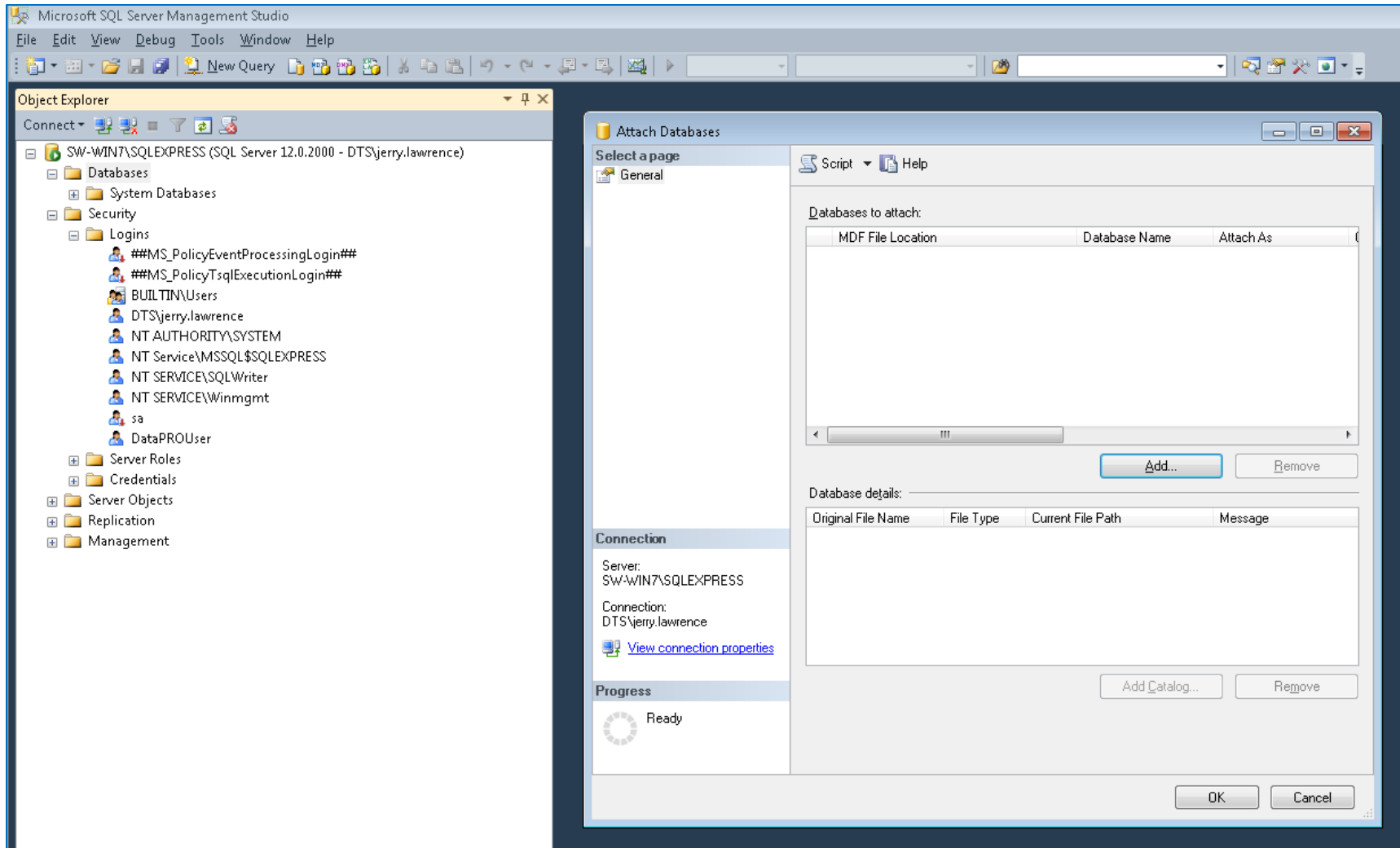

50. Click “Add...”.

51. Browse to the folder where the .mdf/.ldf files were copied, select “DataPRO.mdf” and click “OK”:

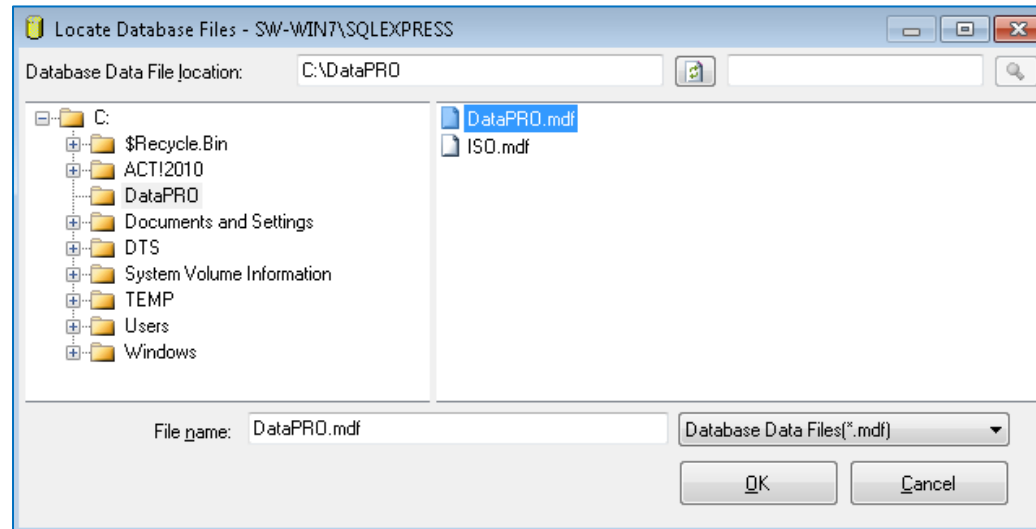

52. Click “Add...” again:

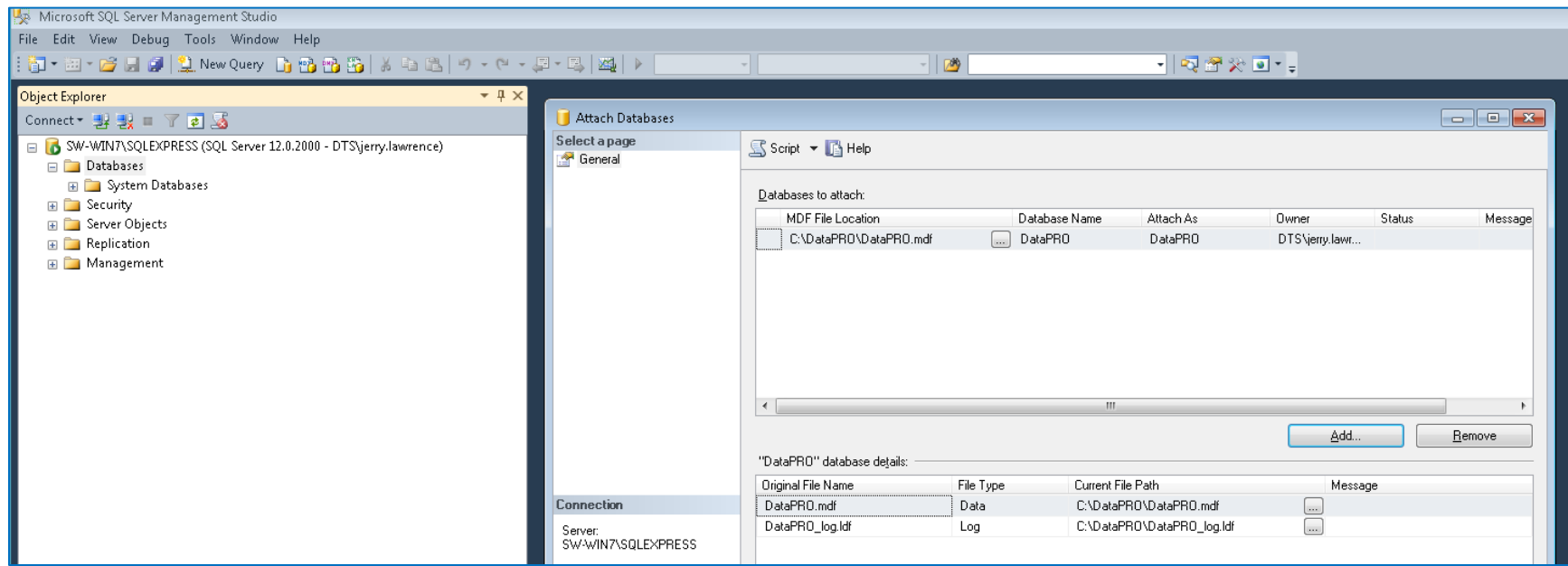

53. Select "ISO.mdf" and click "OK":

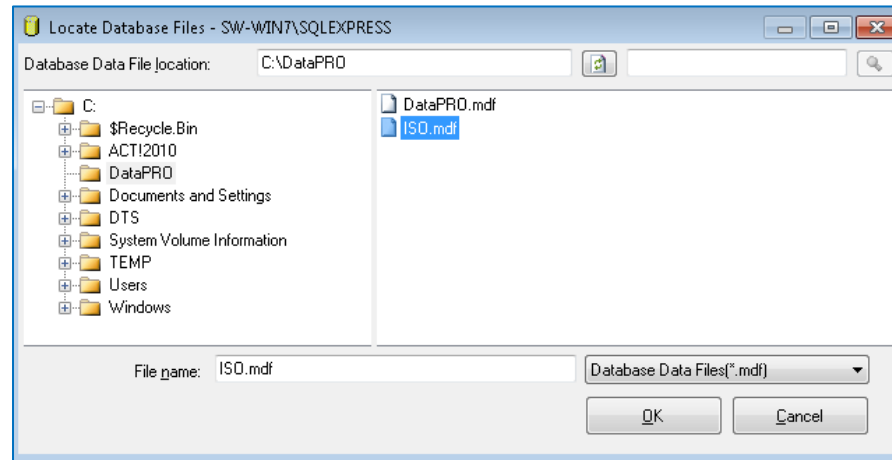

54. Click "OK":

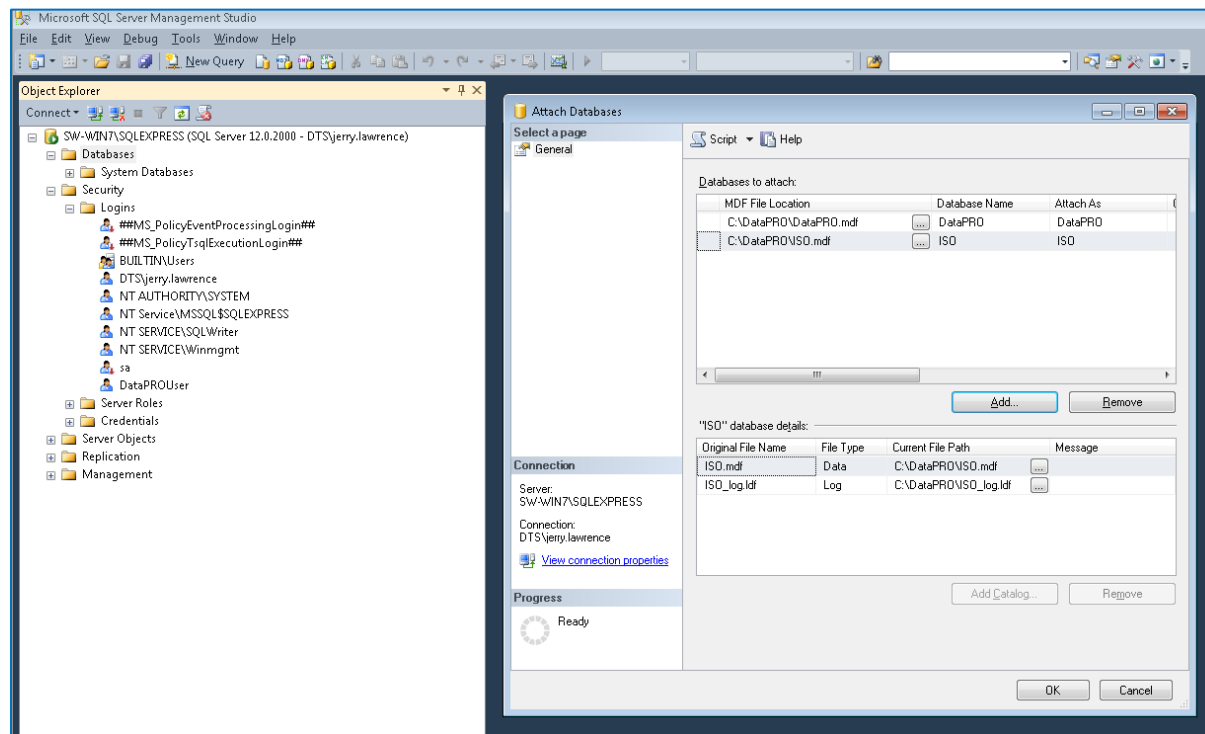

55. Note the “DataPRO” and “ISO” databases under “Databases”.

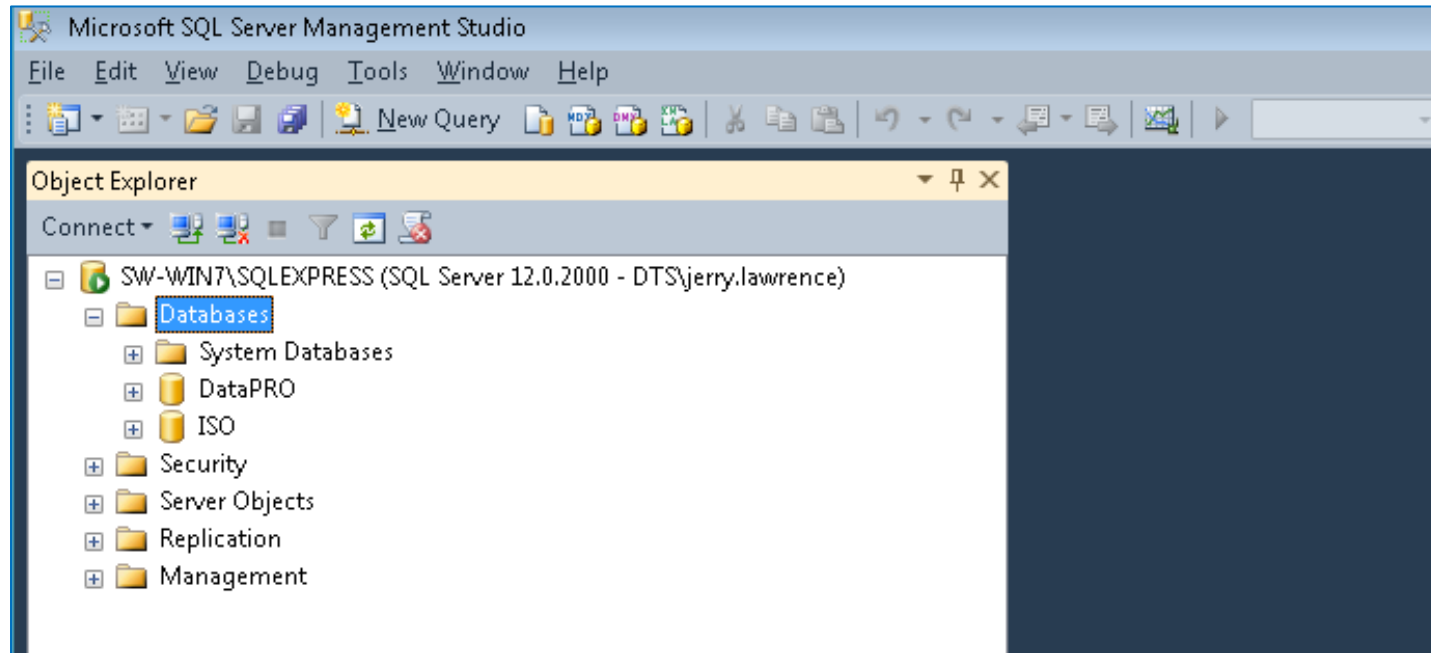

Using SQL Server for the DataPRO Database

After installing DataPRO, modify the following options in the *DataPRO.exe.config* file found in the *C:\DTS\DTS.Suite\<version>* folder:

1. Set DBType to 0 (the default when installed is 1 which causes DataPRO to use a local SQLite database).
2. Set LocalDbHost to the address where SQL Server is installed (either an IP address or a hostname that resolved to that IP address). The config file initially contains “your db host here” for this option.
3. If you want to use Windows authentication when accessing the SQL Server database, thereby avoiding the need to use a clear-text password (LocalDBPassword in the *DataPRO.exe.config* file), set UseNTLMAuthentication to True (the default is False).

If connectivity fails when you run DataPRO, ensure that the LocalDBPassword option in the *DataPRO.exe.config* file matches the password that was used when setting up DataPROUser in SQL Server (or, if UseNTLMAuthentication is True, that SQL Server allows the user’s login) and that the server’s firewall has allowed access to SQL Server.

Backing Up the Centralized (SQL Server) DataPRO Database

1. In SQL Server Management Studio, right-click on “DataPRO”:

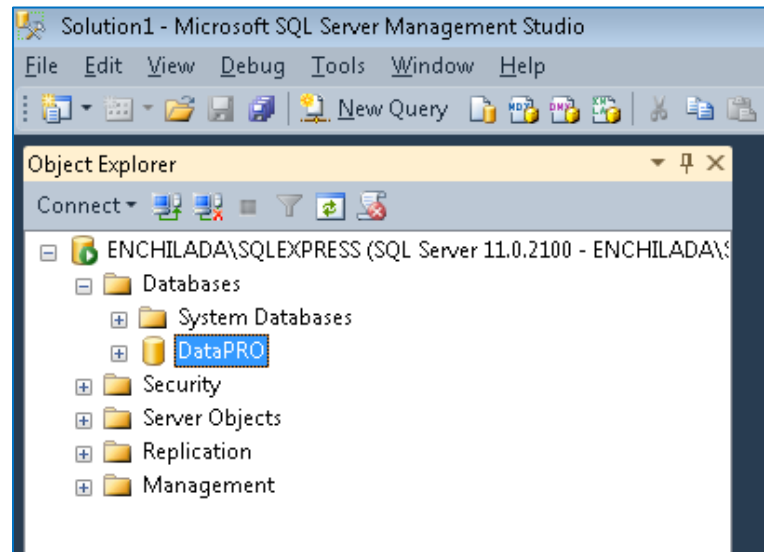

2. Select “Tasks”, “Backup...”.

3. Select “Remove” to delete the file name in the “Destination” box:

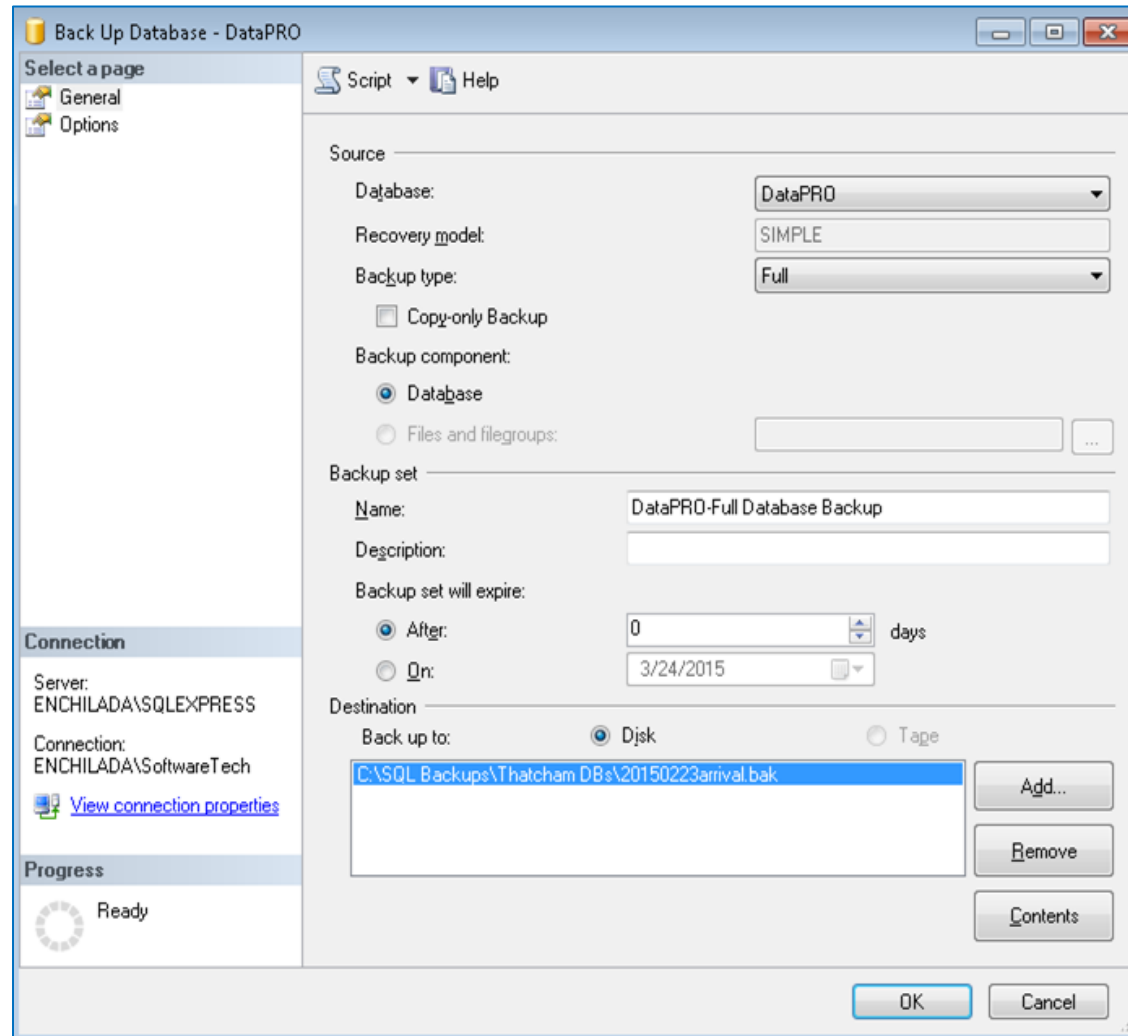

4. Select “Add...”, then browse to your desired location:

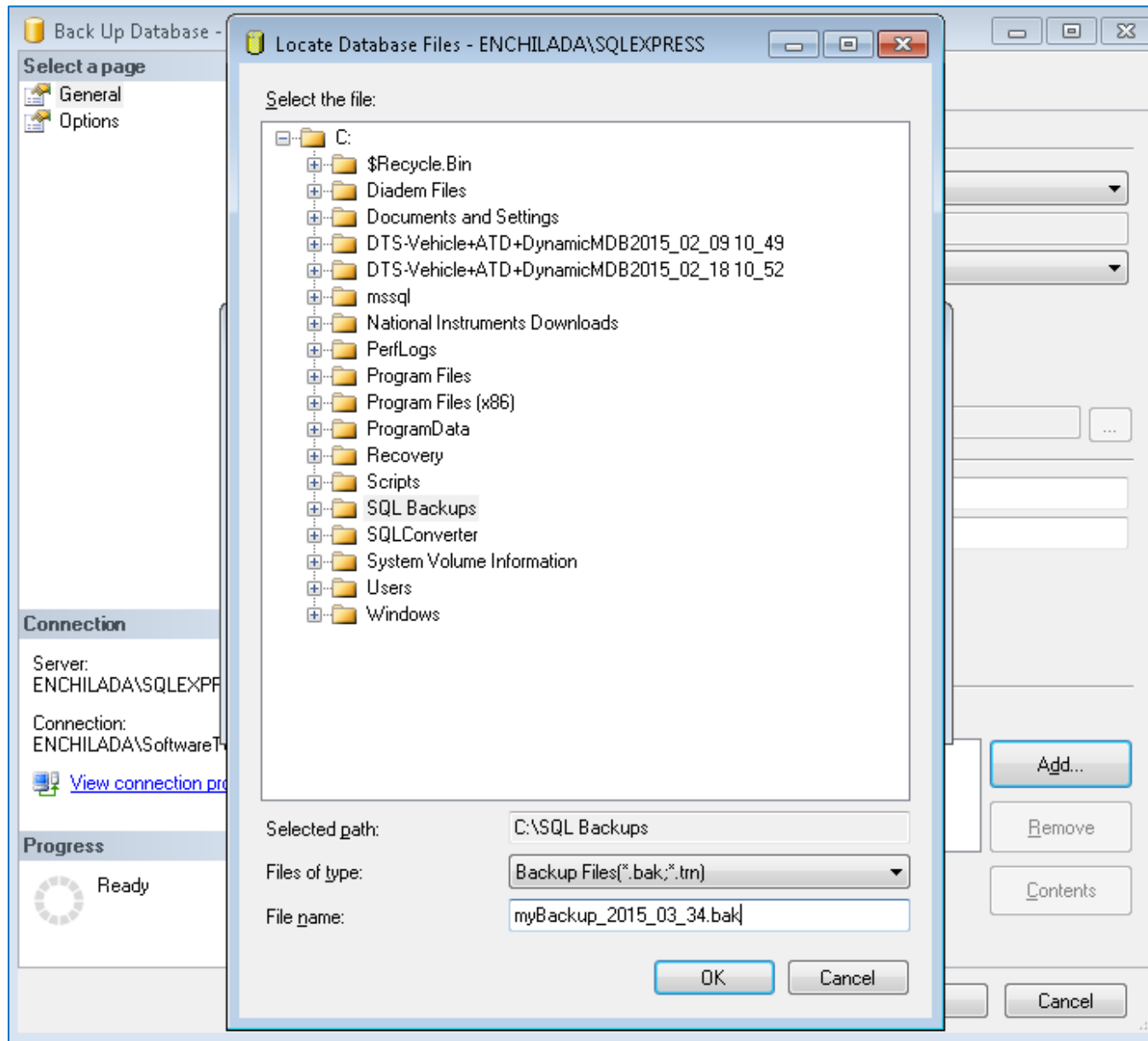

5. Enter your file name and select “OK”:

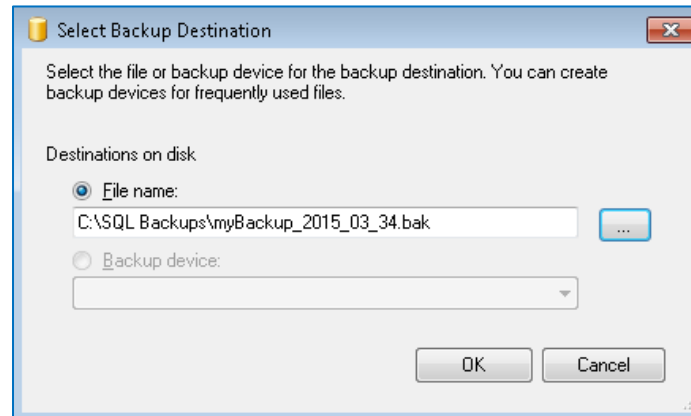

6. Select “OK” again:

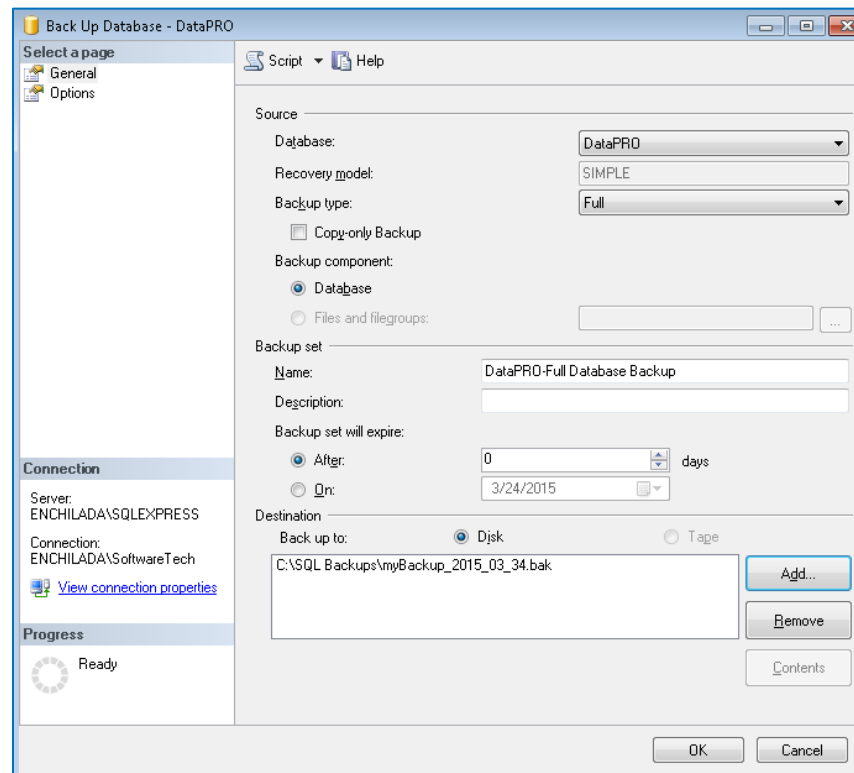

7. In the “Select a page” pane, select “Options”:

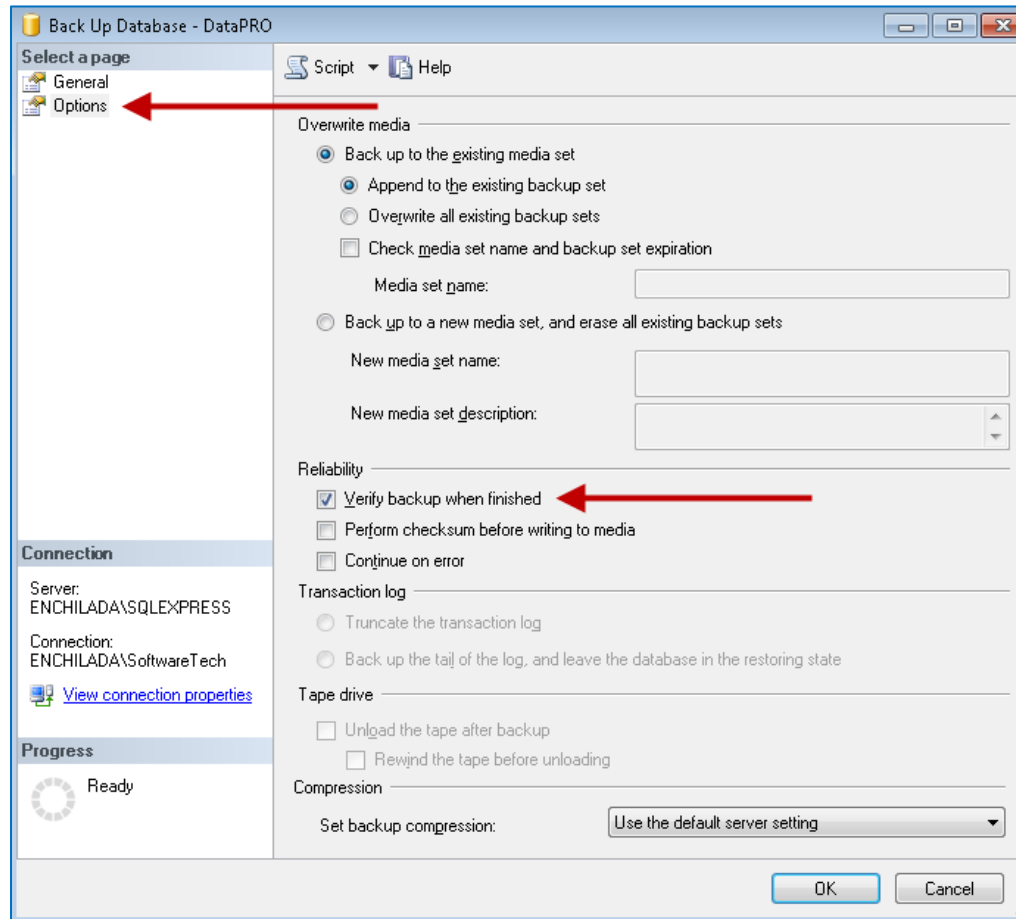

8. Check the “Verify backup when finished” box and select “OK”.

9. Select “OK”:

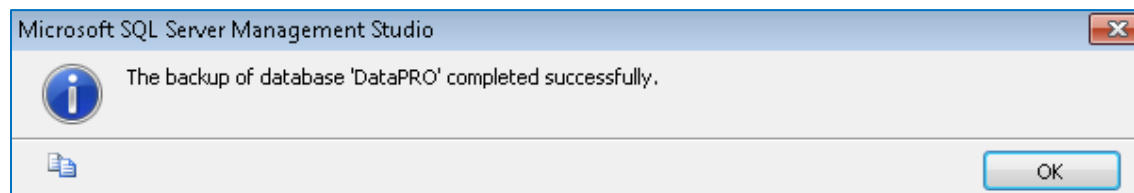

Restoring the Centralized (SQL Server) DataPRO Database

1. In the event that you need to restore the database from a backup, in SQL Server Management Studio, right-click “DataPRO”:

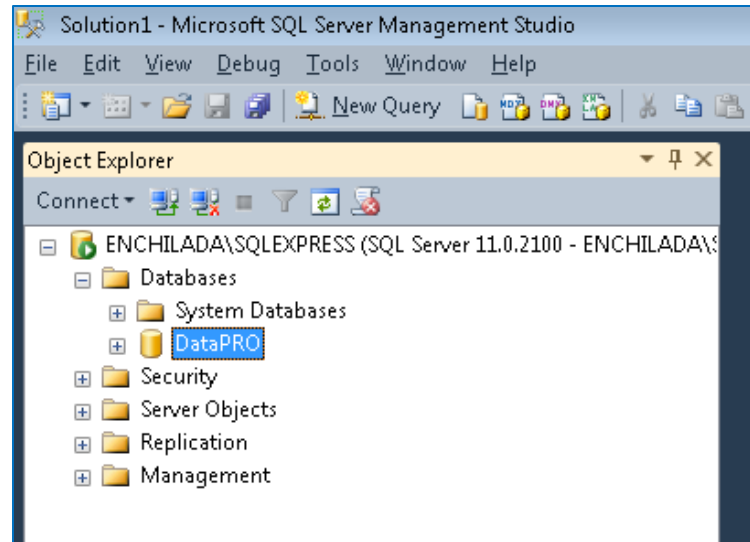

2. Select “Tasks”, “Restore”, “Database...”.

3. In the “Source” box, select “Device” and then the Browse ellipsis:

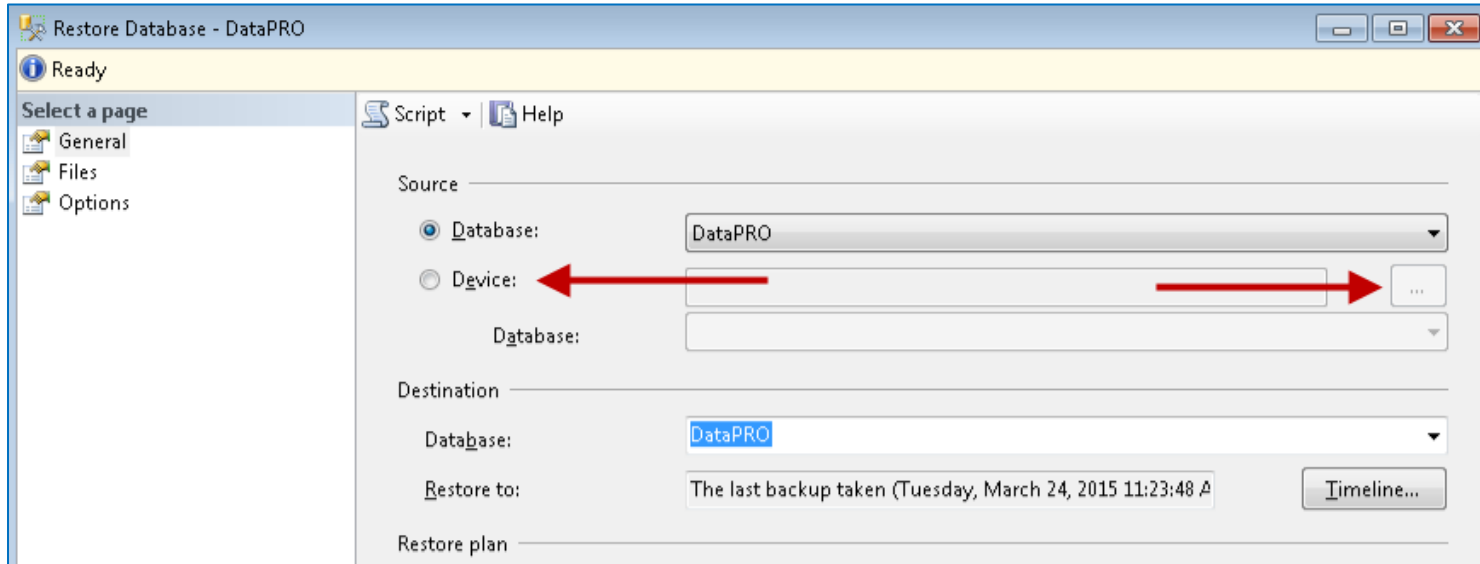

4. Select “Add” and browse to the backup file that you want to be used for the Restore:

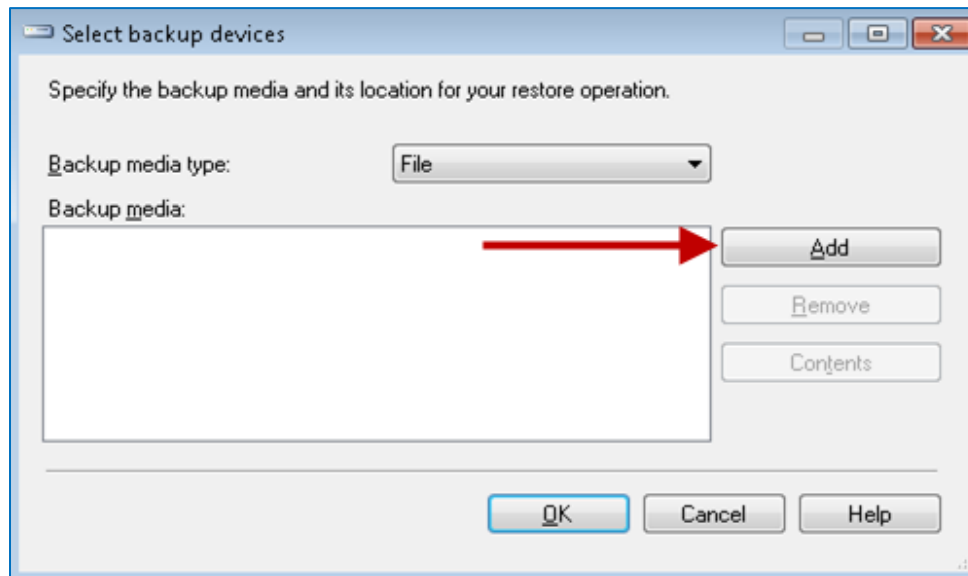

5. Select “OK”:

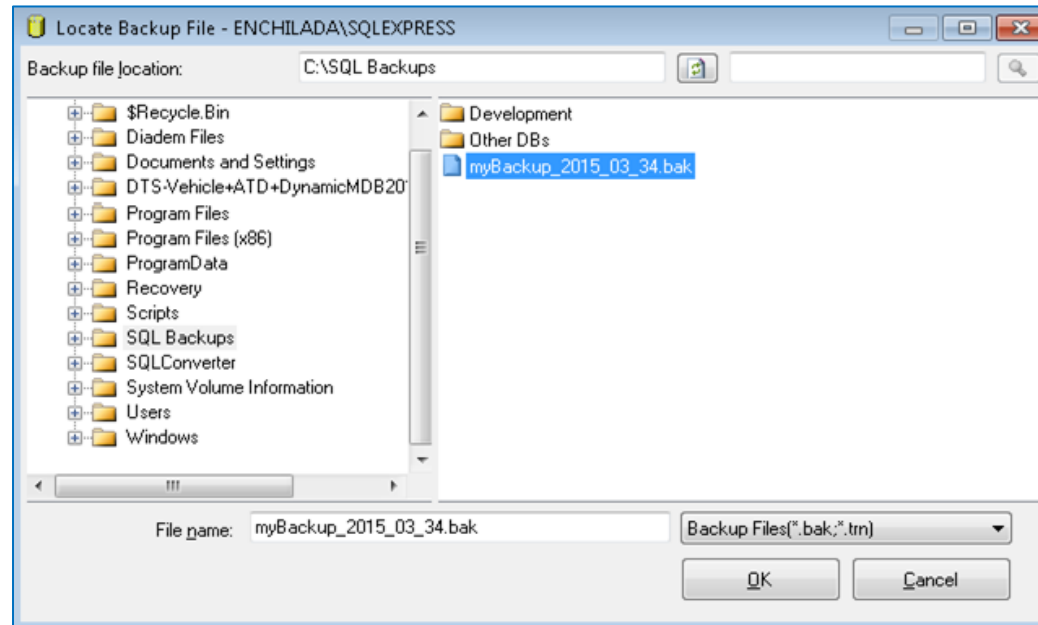

6. Select “OK”:

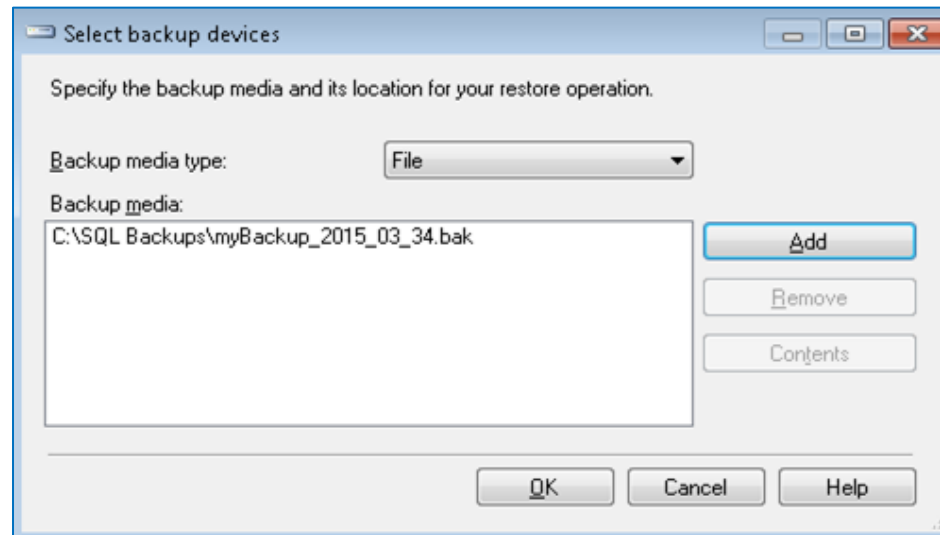

7. In the “Select a page” pane, select “Options” and then in the “Restore options” box, select “Overwrite the existing database (WITH REPLACE)” box. Select “OK”:

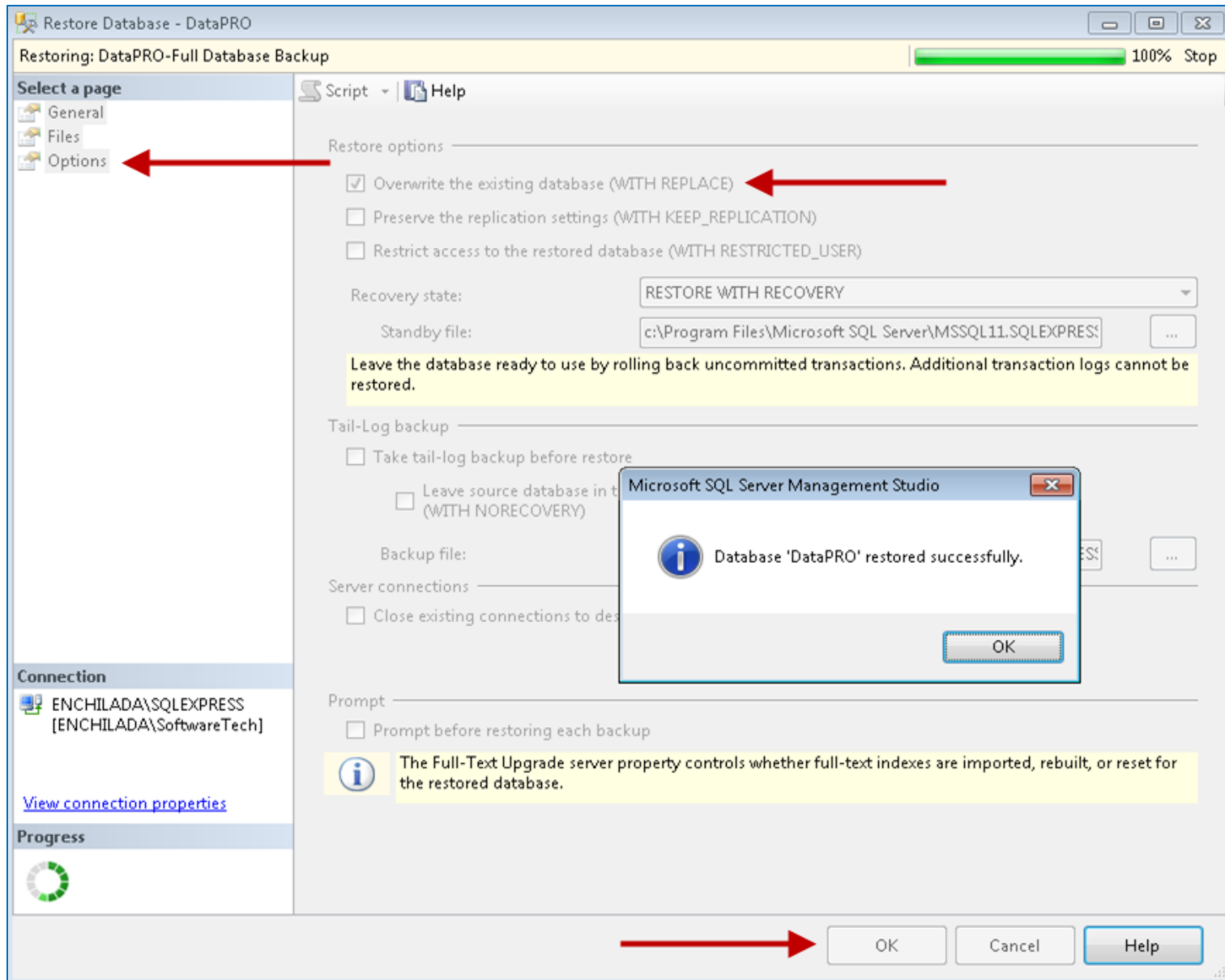

Appendix I: SLICE6 AIR Setup

Because SLICE6 AIR is capable of both Record In Place and Streaming data collection modes, there are a number of additional options for configuring SLICE6 AIR DAS. These options are outlined here, followed by instructions for setting up and running a SLICE6 AIR Streaming test.

Hardware Settings

1. Each SLICE6 AIR can have a Streaming IP Address and port. When multiple SLICE6 AIR units are used in a test, they each need to have a unique IRIG Streaming IP Address and port. DataPRO will configure this during Test Setup.
 - a. The Streaming profile for each individual SLICE6 AIR DAS can optionally be configured using a .csv file by placing a file named "StreamProfileOverride.CSV" in the DataPRO.exe directory (C:\DTS\DTS.Suite*<version>*\DataPRO).
 - b. The format of the .csv file is: "Serial Number, UDP Address and Port, Profile, CH10TimeDataChannelId, CH10DataChannelId, TMNSPacketID, TMNSMessageID".
 - c. No header row is required but the columns must be in that order.
2. SLICE6 AIR units must have the latest firmware installed in order to have access to all features of SLICE6 AIR.

DataPRO Settings

1. “Allow Streaming Modes” must be enabled.
 - a. Found in System settings tab -> Test setup settings -> TestSetupDefaults.
2. “Enable input and output clock source options” should be enabled.
 - a. Found in System Settings tab -> Test Settings navstep.
 - b. If enabled, a Clock sync menu will be present in Test Setup tab -> Info navstep to allow choosing the system grand master type.
 - c. To use 1PPS options, a SLICE6 AIR version G0N4 and DataPRO database version 92 or higher are required.
3. “Allow UART recording modes” will enable SLICE6 AIR units to record both analog data and UART data to flash memory.
 - a. Found in System Settings tab -> Test Setup Defaults navstep -> Test Info.
 - b. 8GB of data storage will be available for analog data and 8GB of data storage will be available for UART data.
 - c. UART data will be downloaded and stored as .bin files with analog data.
4. Select the appropriate UDP Stream Profile from the dropdown options.
 - a. Found in System Settings tab -> Test Setup Defaults navstep -> Realtime options.
5. Set the appropriate UDP Stream Time Channel ID.
 - a. Found in System Settings tab -> Test Setup Defaults navstep -> Realtime options.
6. Set the appropriate UDP Stream Data Channel ID.
 - a. Found in System Settings tab -> Test Setup Defaults navstep -> Realtime options.
7. UDP Stream TmNS Config
 - a. This should not be modified unless advised to do so by DTS.
8. IRIG Time Data Packet Interval (ms)
 - a. Found in System Settings tab -> Test Setup Defaults navstep -> Realtime options.
 - b. Defines the delay in milliseconds between sending time data packets.

Test Setup Configuration

Test Setups are collections of measurement channels, hardware and recording parameters used for data collection. Test Setups can contain existing predefined “Groups” or dynamic groups; random collections of measurement locations and sensors. Each Test Setup can be used for multiple data collection events. (See [Groups](#) on page 66 for instructions on creating a group).

SLICE6 AIR is capable of both Record In Place data acquisition as well as streaming data applications. The below steps will outline how to configure SLICE6 AIR for streaming data applications, as well as Record In Place for applications that deal with both UART and analog (bridge, IEPE, thermocouple sensor) data. For information on configuring and using SLICE6 AIR units for Record In Place applications using only analog inputs, see [Test Setups](#), page 83, and [Run Test](#), page 148.

1. Select the “Test Setups” tab:

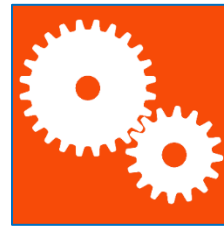

2. Select “Add” to create a new test setup:

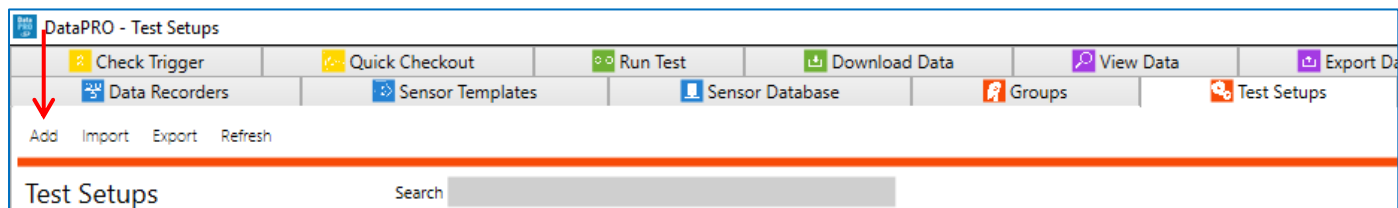

3. The **Info** navstep contains the test parameters. All fields in **red** must be completed:

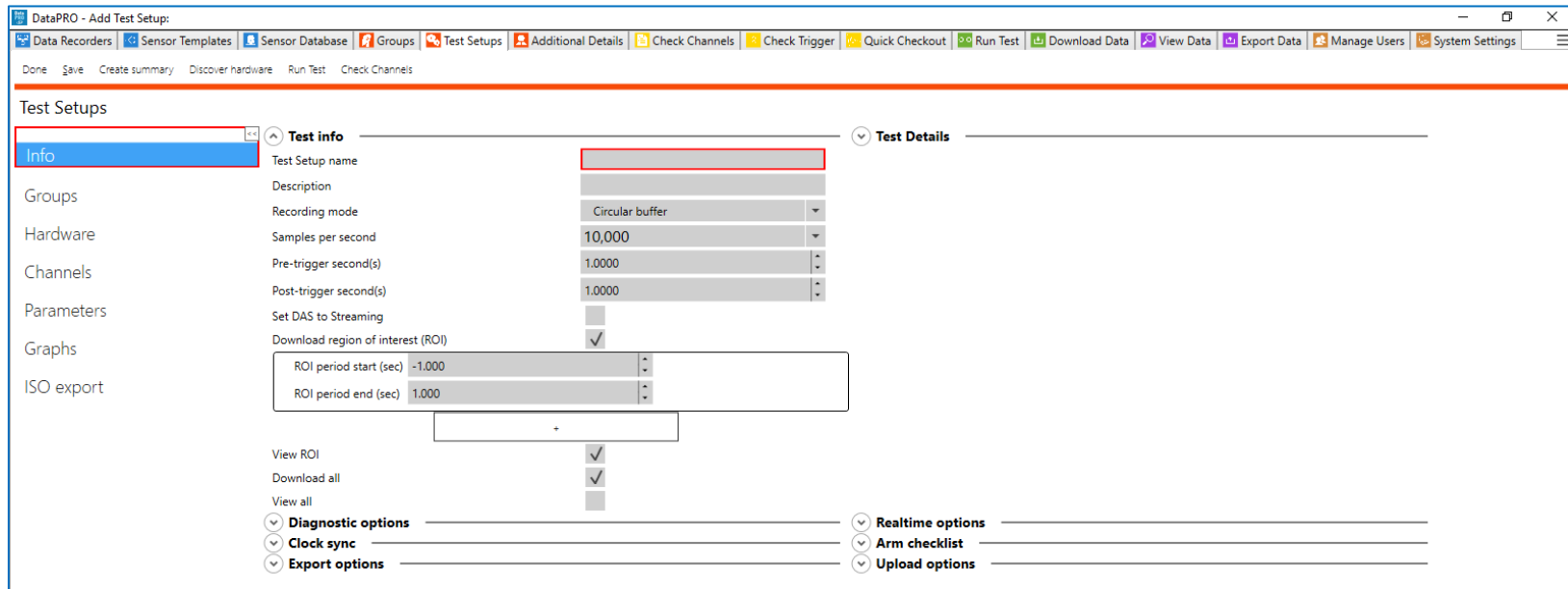

a. The default settings for test parameters can be set in the System Settings tab (See [System Settings](#), page 210.)

NOTE: *Level triggers and Calculated channels are optional navsteps that must be enabled in [System Settings](#), page 210.*

b. Use the arrows to expand/collapse each section menu.

Record In Place with Analog and UART data

4. If recording analog and UART data, select Recording Mode from dropdown:

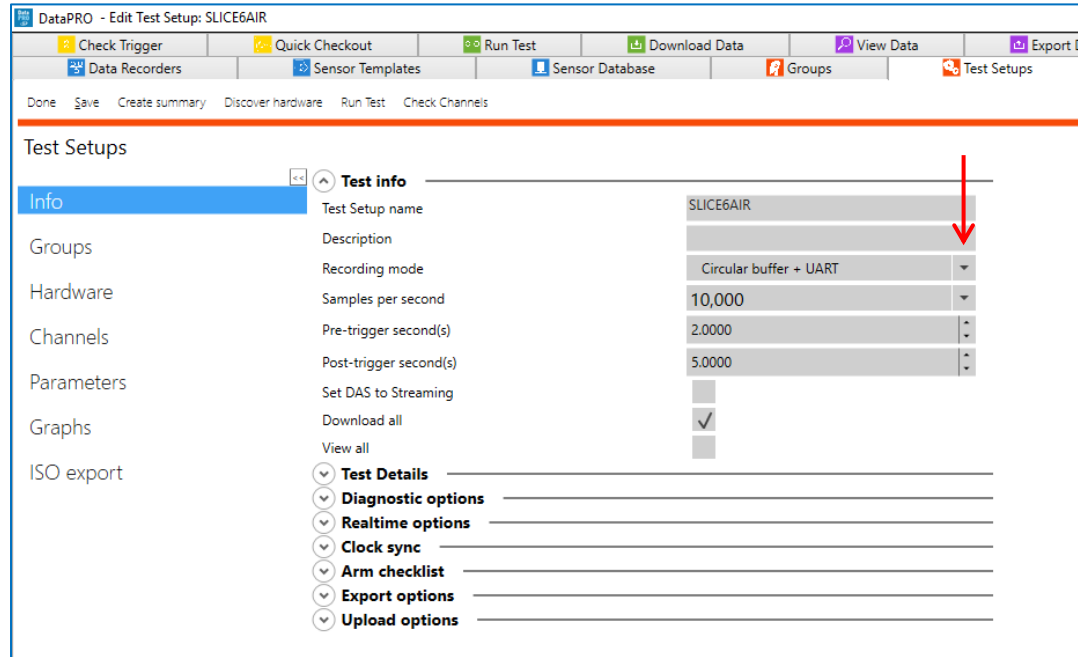

a. When recording analog and UART data:

- i. Ensure “Allow UART recording modes” is enabled in System Settings tab -> Test setup defaults navstep.
- ii. Half the internal memory will be available for analog data and half will be available for UART.
- iii. Download ROI is not available.
- iv. In Streaming mode, Sample Rate is limited to 30,000 samples per second (sps) or lower (UART Baud Rate needs to be set before. See Test Setup Settings in [System Settings](#), page 210, for more information).
- v. UART data will be downloaded as a .bin file in the Binary folder with analog channel data.

Streaming Data with SLICE6 AIR

4. Enable Set DAS to Streaming if configuring for streaming data applications:

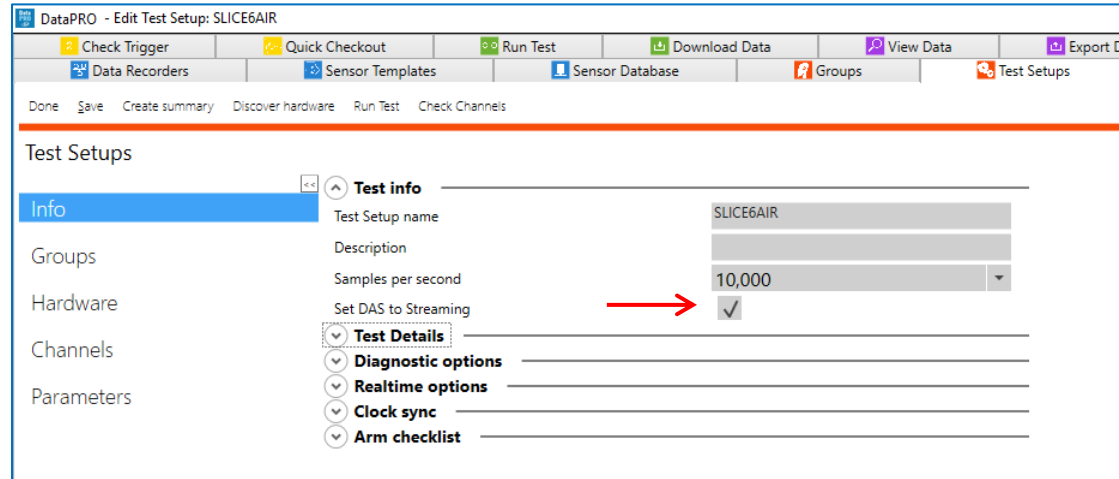

1. Ensure “Allow Streaming Modes” is enabled in System Settings -> Test Setup Settings.
2. Download/View ROI and All and Export Data options are not available with streaming applications.

NOTE: All DAS in test must be SLICE6 AIR in order to configure Test Setup for streaming.

5. Configure Clock Sync options:



- a. Select System grand master type from dropdown:
 - vi. None
 - vii. PTP IEEE 1588
 - viii. IRIG B + 1PPS
 - ix. GPS + 1PPS
 - x. IRIG B
 - xi. 1PPS

6. Select Hardware navstep to define SLICE6 AIR unit to act as Clock Master:

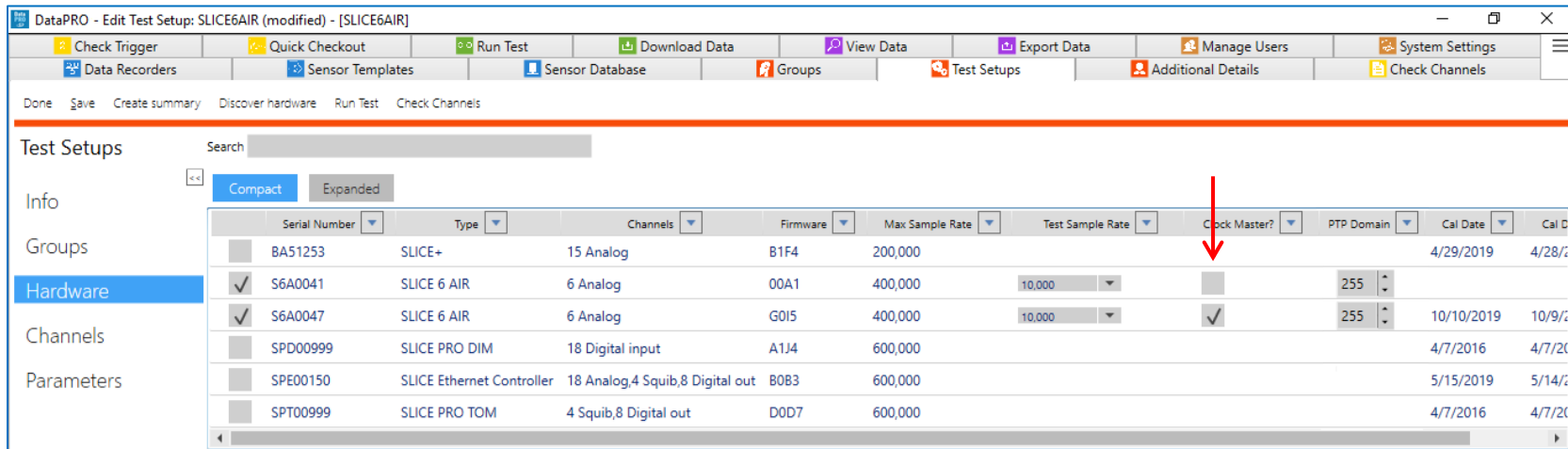

7. If PTP was selected in the previous step, you will also be able to specify the PTP domain (0-255).

NOTE: See the [IEEE 1588 - 2008 Standard](#) for more information on Precision Clock Synchronization Protocol.

NOTE: Continue steps in Prepare: [Test Setups](#), page 83, to configure the Test Setup.

Running a SLICE6 AIR Streaming Test

Use the Run Test tab to initiate a data collection sequence based on the active Test Setup. The settings and parameters in the Test Setup and the System Settings tabs determine the navsteps and behavior of DataPRO during the data collection process (See [Test Setups](#), page 83, or [System Settings](#), page 210, for more information).

The steps and images below are for a Streaming test, where data is not stored on the internal flash memory of the DAS. For information on using SLICE6 AIR DAS in a Record In Place test, see [Run Test](#), page 148.

DTS recommends using the Diagnostic tab(s) prior to collecting data. However, many of the same steps will be repeated with each Data Collection sequence.

Navsteps are configurable for each Test Setup. Not all navsteps listed are required, therefore some steps listed below may not be applicable.

NOTE: See [Run Test](#), page 148, for more information on navsteps and options within each navstep common to Record In Place and Streaming tests.

Select the “Run Test” tab:



1. The **Basic info** navstep displays an overview of the test setup:

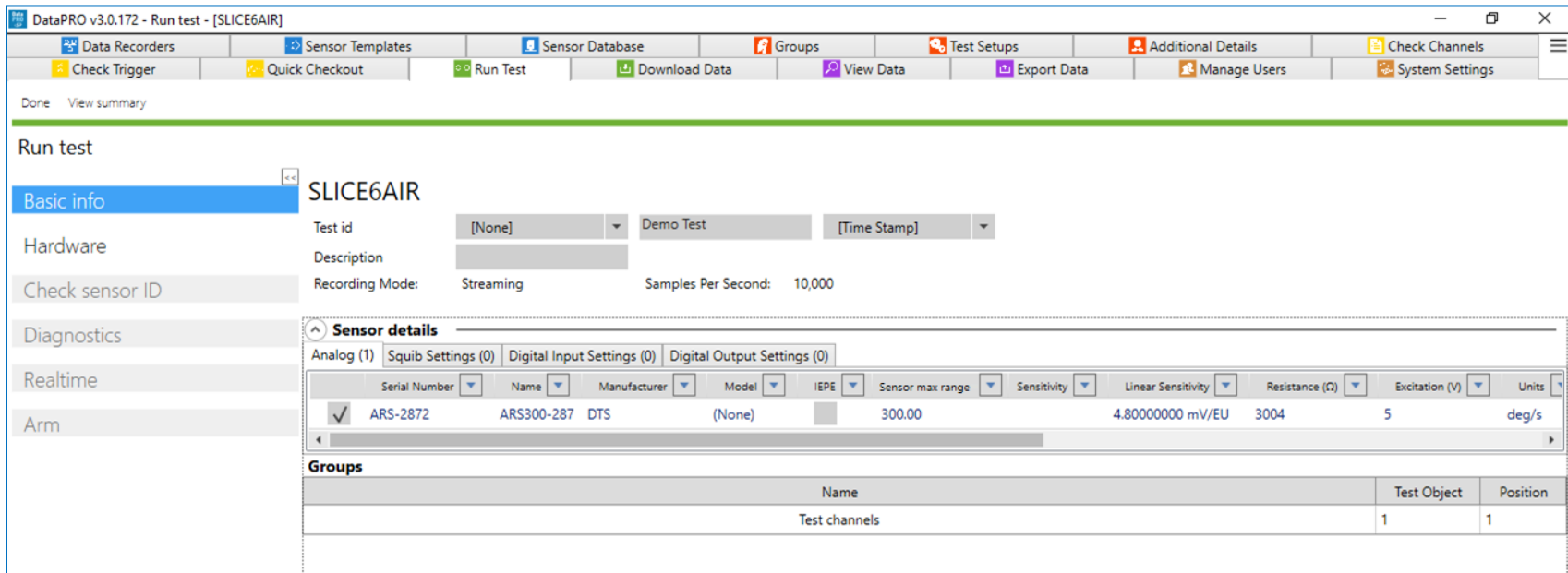

2. Continue to the **Hardware** navstep. DataPRO will attempt to communicate with the hardware associated with the active Test Setup.
 - a. If needed, select Run to re-run the Hardware navstep and reattempt hardware connection.
3. Proceed to **Check sensor ID** navstep to confirm sensors in test setup are properly configured with a hardware channel. Sensors without EID that have not yet been configured with hardware channels will need to be manually assigned before proceeding.
 - a. Channels that are included in the Test Setup but not yet assigned to hardware channels will be listed in the Unresolved Channels table.
 - i. Select from Unresolved Channels table and drag to Hardware Channels table to make assignments.
 - ii. Each Test Setup can be configured to allow progressing with missing sensors (unresolved channels) (See [System Settings](#), page 210, for more information).
 - b. Sensor IDs that were detected but are not included in the Test Setup will be displayed in the Extra Sensor IDs table. If the sensor ID(s) are associated with sensors in the Sensor Database, the serial number(s) will be displayed.

- c. The key defines what different shading in the Hardware Channels table indicates (See [Check Channels](#), page 128, for more information).
4. Continue to **Diagnostics** navstep. DataPRO will automatically configure the DAS.
 - a. Select Run to perform a diagnostic checkout on all DAS/Channels included in Test Setup.
 - b. Select Run (DAS) to perform a diagnostic checkout on only the selected DAS.
 - c. Select Run (Channel) to perform a diagnostic checkout on only the selected Channel.
 - d. Select Low Power to turn off excitation voltage. Diagnostics will have to be performed again to resume data collection sequence.
5. A pre-test diagnostics report will be automatically generated and saved with the test data folder (See

6. [Appendix E: DataPRO File Structure](#), page 275, for more information).
 - a. Select View report to display this report.

7. The (optional) **Realtime** navstep allows for Realtime verification of each channel.
 - a. The controls of Realtime in a data collection sequence are the same as the controls for the Check Channels diagnostic tab (See [Check Channels](#), page 128, for more information).

NOTE: Realtime AAF ratio is 1:1 by default. This setting can be changed in the DataPRO.exe.config file. See DataPRO Settings Manual for more information about the config file.

8. Continue to the **Arm Checklist** navstep (if enabled).
 - a. If enabled, the Arm Checklist will run system tests as defined in the Test Setup.

9. Continue to the **Arm** navstep:

Group	DAS	Test sample rate	Input Voltage Status	Battery Voltage Status	Time left in arm	Triggered	Faults	Status
Test channels	S6A0047	10,000	14.9 V	---		<input type="checkbox"/>		

- a. Confirm Test Setup, Test ID, recording mode and parameters, channel count, group(s) and associated DAS.
- b. Verify Input Voltage.
- c. System status displays.
 - i. “Waiting for user selection”: Select Run to arm the system.
 - ii. “Trigger: waiting” indicates that a trigger has not been received.
 - iii. “Faults: clear” indicates that no faults have been detected.

NOTE: If enabled, additional Arm Prepare navstep will be present. See [Appendix D: Quick Arm](#) for more information.

10. Select Run to arm the system:

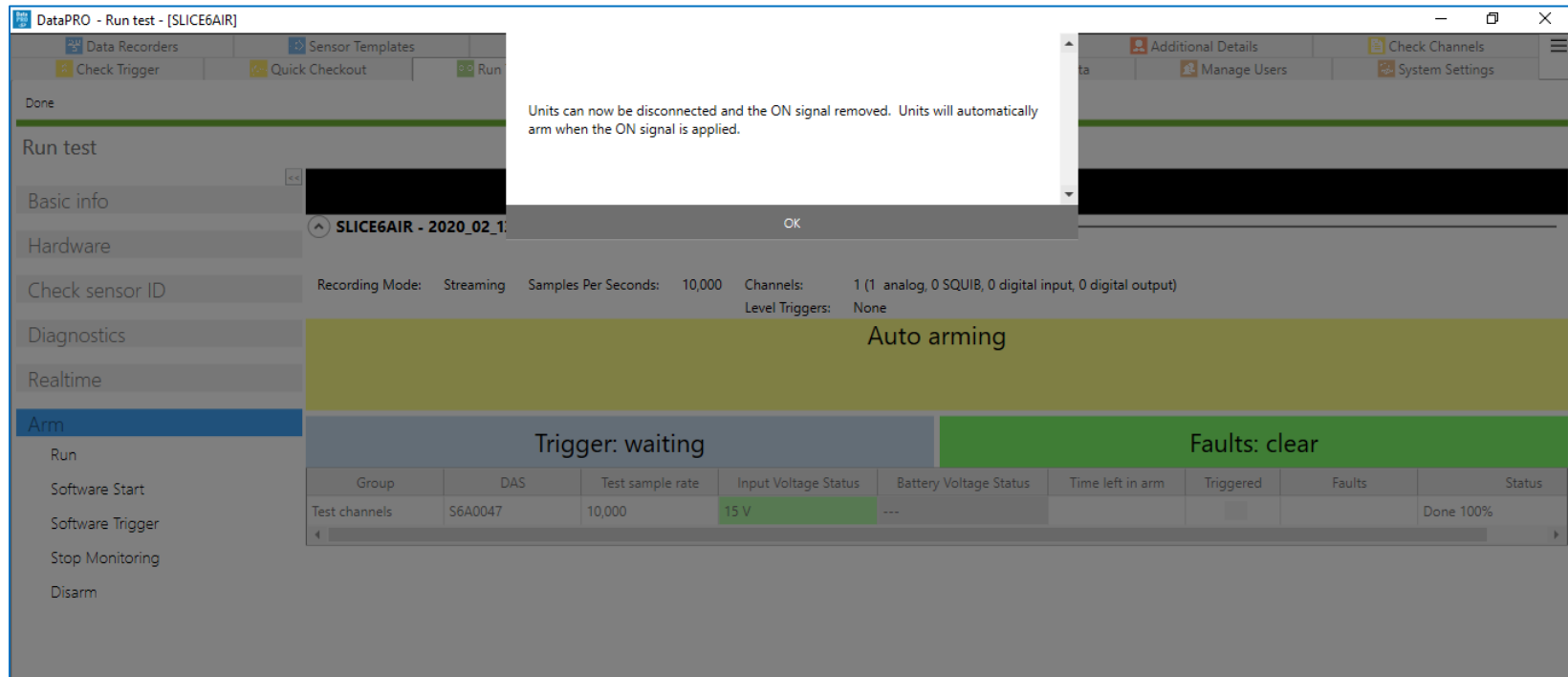

- DataPRO will configure the SLICE6 AIR for streaming data collection.
- Status LED will flash blue to indicate DAS is being configured for streaming.

11. Select Done to complete the process.

12. Power cycle or remove and re-apply the ON signal.

- Once the device is actively streaming, both LEDs should be solid green.

NOTE: Streaming data can now be viewed with a third-party viewer. See that manufacturer's documentation for configuring the display.

13. The SLICE6 AIR will continue to stream data until power is cycled or it is disarmed.

NOTE: *If the DAS is configured to “Enable repeat when auto-arm/streaming”, it will continue to boot into streaming mode and must be disarmed by selecting Stop Streaming from within the Arm navstep.*

- a. On reconnecting the DAS, start a new Run Test instance with the appropriate active Test Setup.
- b. DataPRO will detect the SLICE6 AIR is streaming in the Hardware navstep:

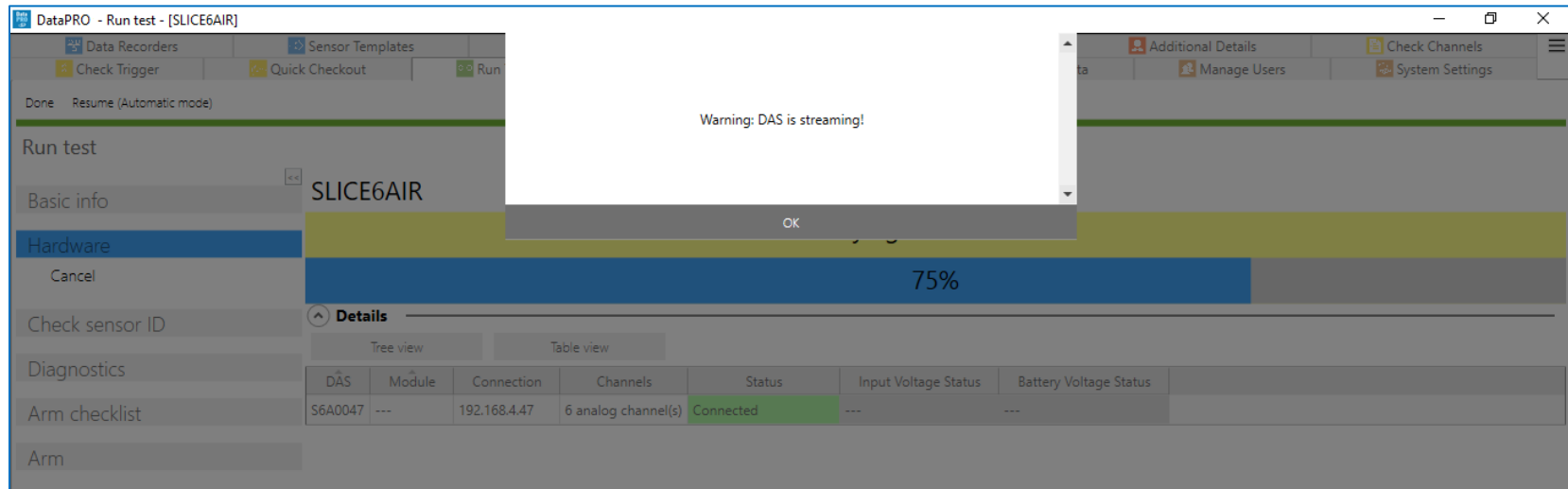

- c. The Arm navstep will be the only available navstep.
 - i. Select Stop Streaming and OK when prompted:

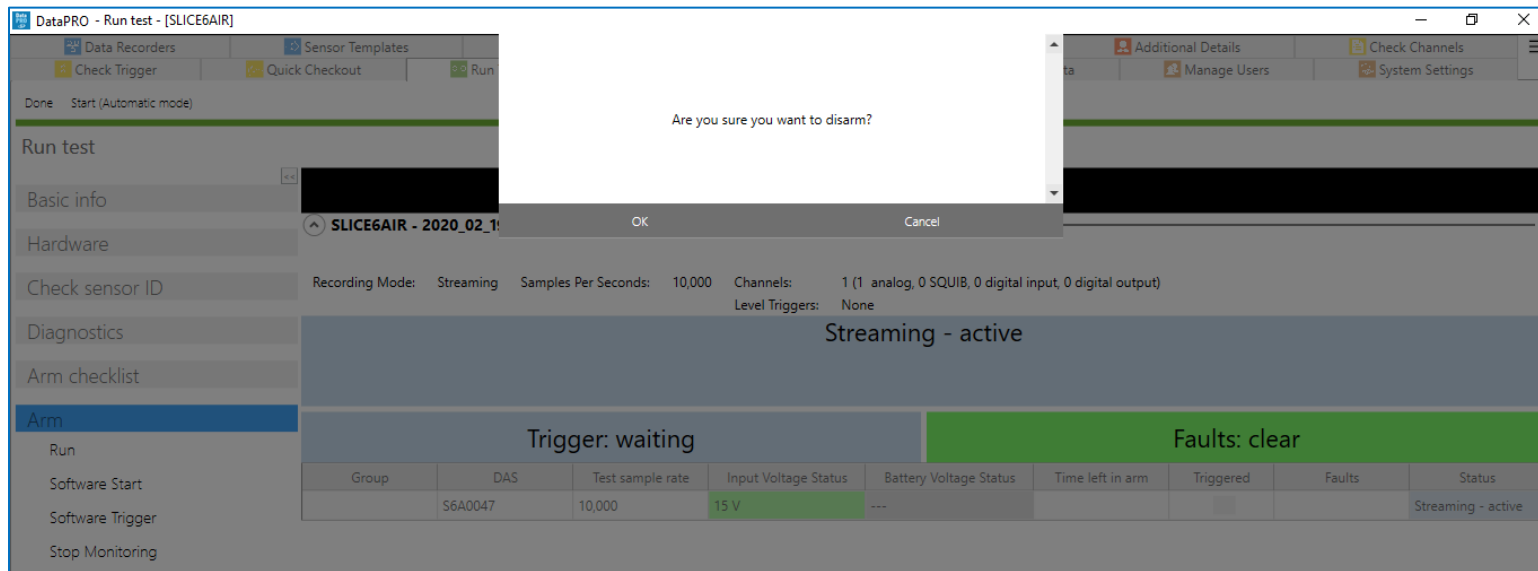
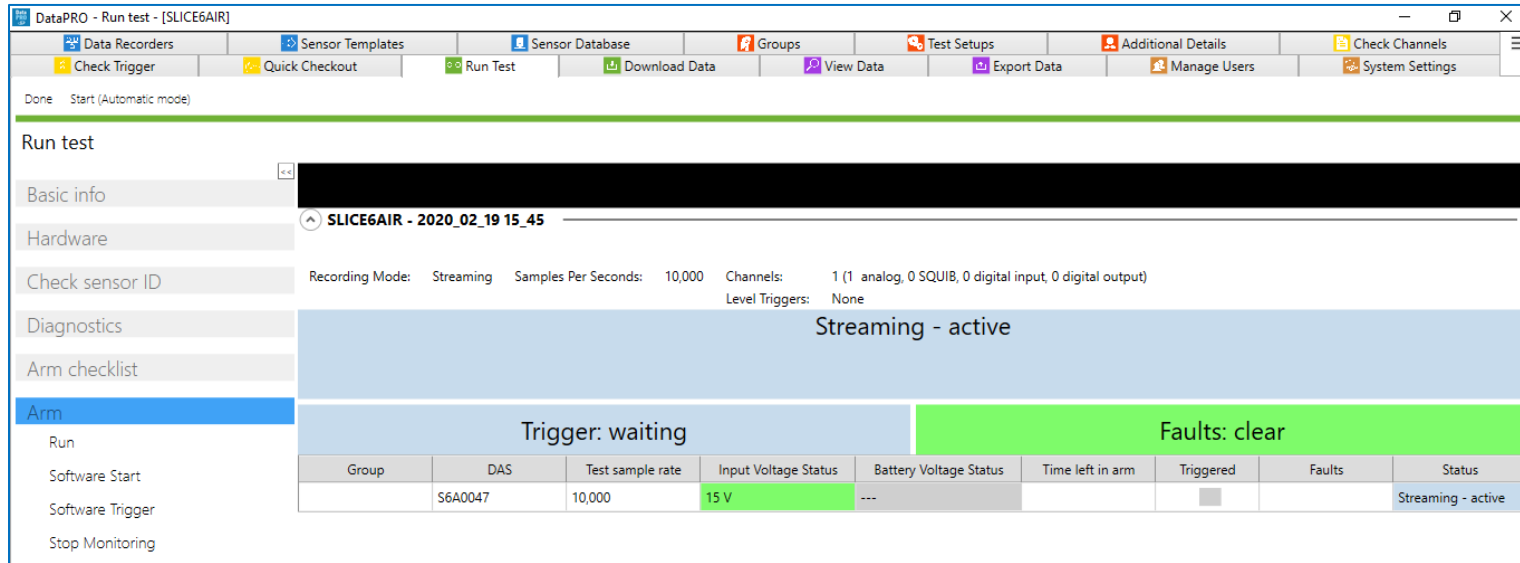

- d. DAS will no longer be streaming data and can be re-configured for another test.

Streaming Data via UART

SLICE6 AIR devices are able to stream data out via UART as an alternative to using a network stream.

1. In the Sensor Database, create a **stream output** sensor and select **ADC-to-UART stream** as the stream profile.
Note: This option requires Use advanced streaming profiles to be enabled in [System Settings](#) -> [Sensor Settings](#).

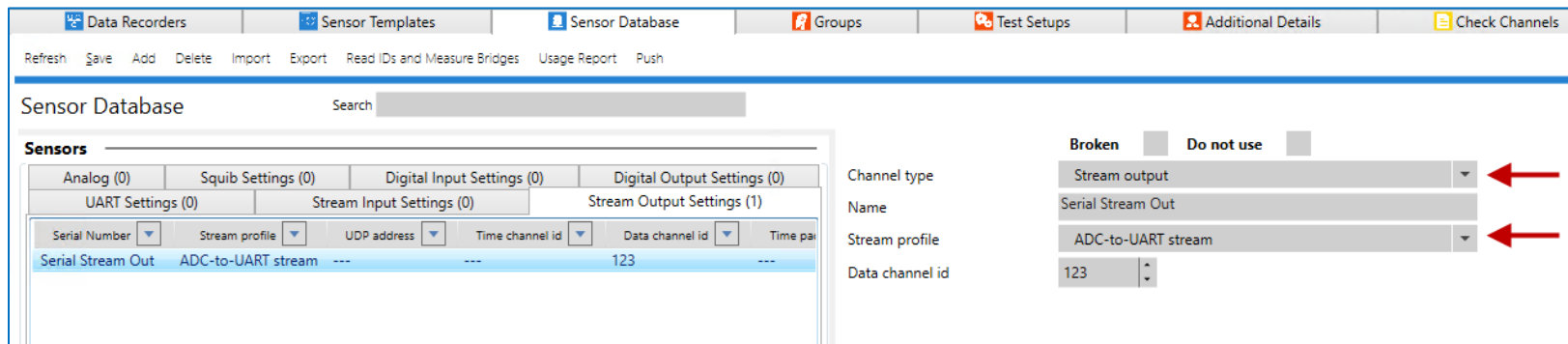

Specify the desired data channel id, then save.

Note: if your test requires multiple ids, you will need to configure multiple sensors.

2. Create a second sensor, this time with the UART channel type.

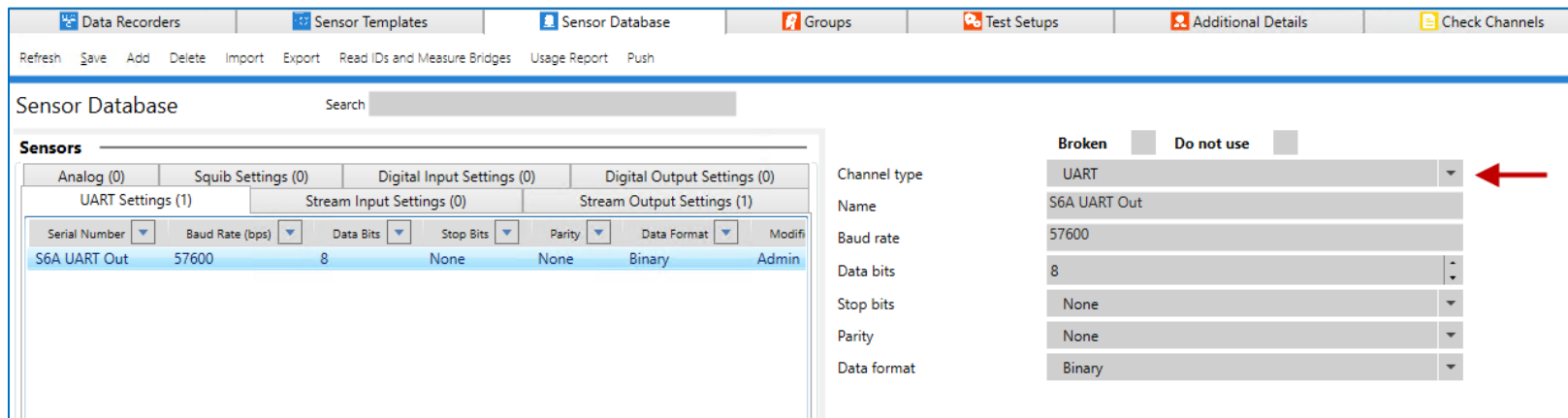

Set other options as required to make a connection between your devices and what will be receiving the streamed data. The data format dropdown can be ignored since this only pertains to file extensions for store-in-place tests.

3. Create a streaming test. After configuring your desired analog channels, connect the unit's stream output hardware channel with its respective sensor created in step 1. Then configure a UART hardware channel with its respective sensor.

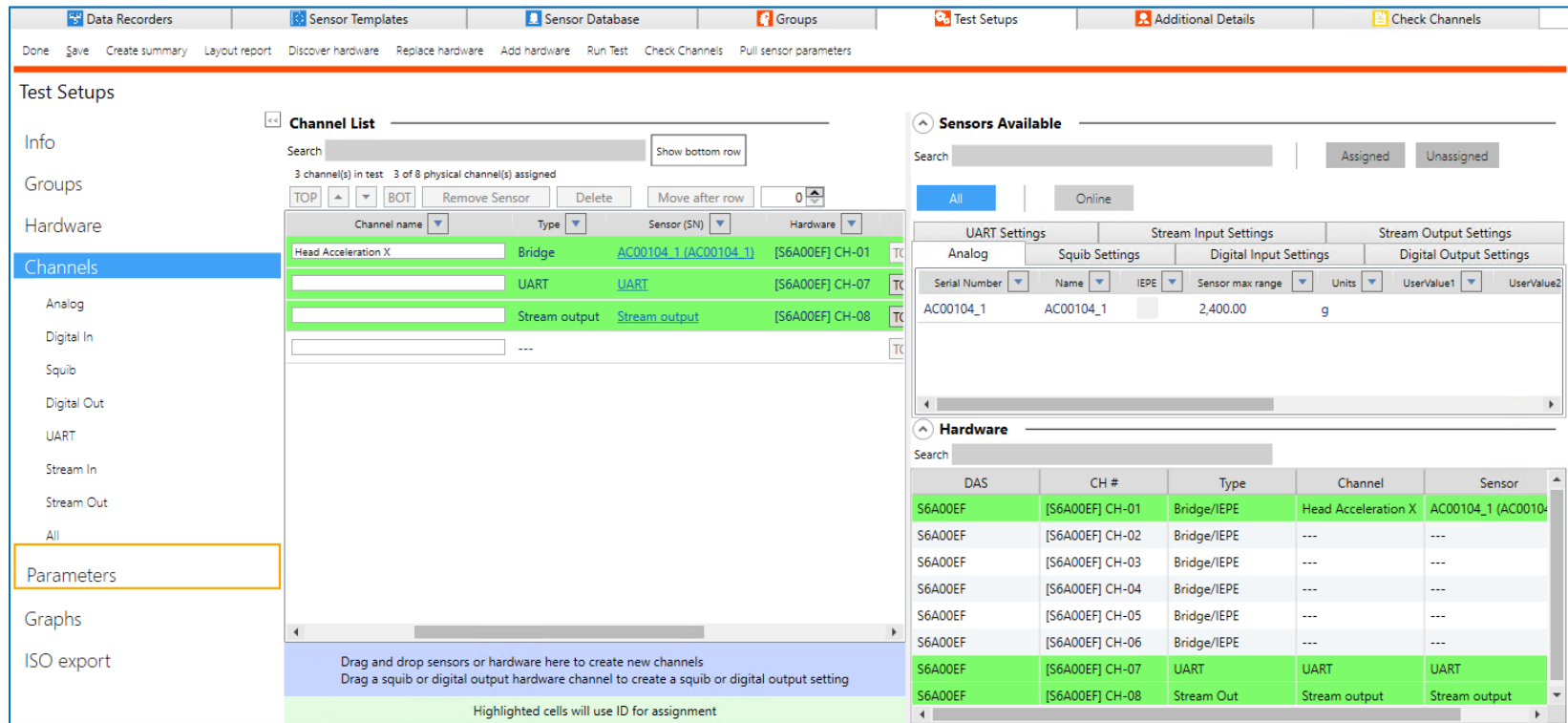

4. Connect the UART Tx and Ground pins from the SLICE6 AIR to your receiving device.
5. Run the test. When the SLICE6 AIR unit starts up again after arming, data will be output via UART to your receiving device.

Appendix J: TSR AIR Setup

Test Setup Configuration

TSR AIR devices operate somewhat differently than other devices in DataPRO in that they have embedded sensors. Adding the TSR AIR into a test automatically adds all of the embedded sensors on that TSR AIR as channels in the test.

TSR AIR devices can be detected in Edit/Add Test Setup in Discover Hardware:

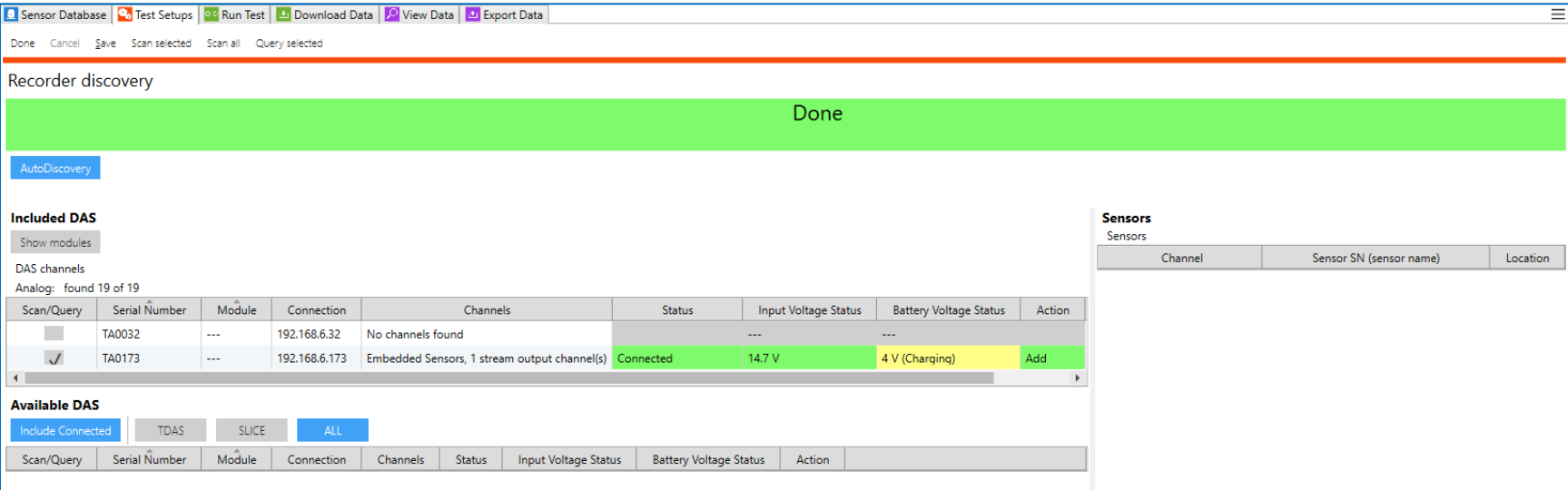

The screenshot shows the 'Recorder discovery' window in DataPRO. A green bar at the top indicates 'Done'. Below this, there is a table of discovered devices. The device TA0173 is highlighted, showing it is connected and has embedded sensors. The 'Sensors' panel on the right shows a table with columns for Channel, Sensor SN (sensor name), and Location.

Scan/Query	Serial Number	Module	Connection	Channels	Status	Input Voltage Status	Battery Voltage Status	Action
<input type="checkbox"/>	TA0032	---	192.168.6.32	No channels found	---	---	---	
<input checked="" type="checkbox"/>	TA0173	---	192.168.6.173	Embedded Sensors, 1 stream output channel(s)	Connected	14.7 V	4 V (Charging)	Add

Channel	Sensor SN (sensor name)	Location
---------	-------------------------	----------

Info

- TSR AIR devices only support Active and Scheduled recording modes and DataPRO won't arm them in the same test with non TSR AIR devices.
 - Scheduled Mode allows the device to have a set schedule when to wake and record.
 - Active Mode can record as soon as it is armed, and will also arm on boot if power or the on signal are removed and then later re-applied.
- The clock sync method GPS + 1PPS is only supported for TSR AIR devices with firmware K0E3 or higher.

Channels

The Channels navstep shows all of the channels that were added for the embedded sensors:

The screenshot displays the 'Test Setups' interface. The 'Channels' section on the left lists 12 channels, each with a name, type, sensor ID, hardware ID, and navigation controls. The 'Sensors Available' section on the right shows a table of sensors with columns for Serial Number, Name, IEPE, Sensor max range, Units, First use date, and Cal Due Date. Below the sensors is a 'Hardware' section with a table listing DAS, CH #, Type, Channel, and Sensor.

Channel name	Type	Sensor (SN)	Hardware	TOP	BOT
TA0173-Low g Linear 1	Embedded	TA0173-Low g Linear 1	TA0173-Low g CH-01	001	
TA0173-Low g Linear 2	Embedded	TA0173-Low g Linear 2	TA0173-Low g CH-02	002	
TA0173-Low g Linear 3	Embedded	TA0173-Low g Linear 3	TA0173-Low g CH-03	003	
TA0173-High g Linear 1	Embedded	TA0173-High g Linear 1	TA0173-High g CH-01	004	
TA0173-High g Linear 2	Embedded	TA0173-High g Linear 2	TA0173-High g CH-02	005	
TA0173-High g Linear 3	Embedded	TA0173-High g Linear 3	TA0173-High g CH-03	006	
TA0173-Angular Rate 1	Embedded	TA0173-Angular Rate 1	TA0173-ARS CH-01	007	
TA0173-Angular Rate 2	Embedded	TA0173-Angular Rate 2	TA0173-ARS CH-02	008	
TA0173-Angular Rate 3	Embedded	TA0173-Angular Rate 3	TA0173-ARS CH-03	009	
TA0173-Temperature	Embedded	TA0173-Temperature	TA0173-Atm CH-01	010	
TA0173-Pressure	Embedded	TA0173-Pressure	TA0173-Atm CH-03	012	

Serial Number	Name	IEPE	Sensor max range	Units	First use date	Cal Due Date
2KG005	DTS Scale LC		2,000.00	Grams	---	6/3/2023
8769-1A-190	S2 Kulite 100 PSI		100.00	PSI	---	6/3/2023
9743	3055B1T	✓	500.00	g	---	6/3/2023
A641001	A64C Accel		500.00	g	---	6/3/2023

DAS	CH #	Type	Channel	Sensor	Clear
TA0173	TA0173-Low g CH-01	Embedded	TA0173-Low g Linear 1	TA0173-Low g Linear 1	Clear
TA0173	TA0173-Low g CH-02	Embedded	TA0173-Low g Linear 2	TA0173-Low g Linear 2	Clear
TA0173	TA0173-Low g CH-03	Embedded	TA0173-Low g Linear 3	TA0173-Low g Linear 3	Clear
TA0173	TA0173-High g CH-01	Embedded	TA0173-High g Linear 1	TA0173-High g Linear 1	Clear
TA0173	TA0173-High g CH-02	Embedded	TA0173-High g Linear 2	TA0173-High g Linear 2	Clear
TA0173	TA0173-High g CH-03	Embedded	TA0173-High g Linear 3	TA0173-High g Linear 3	Clear
TA0173	TA0173-ARS CH-01	Embedded	TA0173-Angular Rate 1	TA0173-Angular Rate 1	Clear
TA0173	TA0173-ARS CH-02	Embedded	TA0173-Angular Rate 2	TA0173-Angular Rate 2	Clear

You may remove or delete channels as desired. If a channel has been removed, you can re-add it by dragging the hardware channel back into the test in the area below the current channel list.

NOTE: *If the recording rate for a TSR AIR is set to 500 samples per second or lower, the high g channels will not appear in the channel list since the TSR AIR does not capture data for the high g sensor at low sample rates.*

Parameters

The Parameters screen allows you to configure the Range (CAC) and AC Coupling for low g channels, in addition to other options.

- Range – the acceleration range at which the channel collects data (50 g, 25 g, 12 g, or 6 g). Changing the range for one of the low g channels will update it for the other low g channels; similarly, changing the range for one angular rate channel will update it for the other angular rate channels.
- AC (alternating coupling) – allows only AC signals to pass through, removing the DC offset and normalizing the signal to a mean of zero. Changing the state of the AC Coupling checkbox for a channel will change it for the other channels on that DAS as well.

The screenshot shows the 'Parameters' screen in a software interface. The interface includes a navigation menu on the left with options like 'Data Recorders', 'Sensor Templates', 'Sensor Database', 'Groups', 'Test Setups', 'Additional Details', 'Check Channels', 'Check Trigger', 'Quick Checkout', 'Run Test', 'Download Data', 'View Data', 'Export Data', 'Manage Users', and 'System Settings'. The main area is titled 'Test Setups' and contains a table of sensor channels. A 'Modify global range CAC' button is located above the table.

Order	Channel name	Sensor (SN)	Channel full-scale	Sensor max range	Sensitivity	Units	Channel filter class	Polarity	Zero Method	Start (sec)	End (sec)	Initial offset	AC coupling
001	TA0034-Low g Linear 1	TA0034-Low g Linear 1	50	50	1.00000000	g	1650 (CFC1000)	+	Absolute zero	N/A	N/A	---	<input type="checkbox"/>
002	TA0034-Low g Linear 2	TA0034-Low g Linear 2	50	50	1.00000000	g	1650 (CFC1000)	+	Absolute zero	N/A	N/A	---	<input type="checkbox"/>
003	TA0034-Low g Linear 3	TA0034-Low g Linear 3	50	50	1.00000000	g	1650 (CFC1000)	+	Absolute zero	N/A	N/A	---	<input type="checkbox"/>
004	TA0034-High g Linear 1	TA0034-High g Linear 1	---	400	1.00000000	g	1650 (CFC1000)	+	Absolute zero	N/A	N/A	---	<input type="checkbox"/>
005	TA0034-High g Linear 2	TA0034-High g Linear 2	---	400	1.00000000	g	1650 (CFC1000)	+	Absolute zero	N/A	N/A	---	<input type="checkbox"/>
006	TA0034-High g Linear 3	TA0034-High g Linear 3	---	400	1.00000000	g	1650 (CFC1000)	+	Absolute zero	N/A	N/A	---	<input type="checkbox"/>
007	TA0034-Angular Rate 1	TA0034-Angular Rate 1	2000	2000	1.00000000	deg/sec	1650 (CFC1000)	+	Absolute zero	N/A	N/A	---	<input type="checkbox"/>
008	TA0034-Angular Rate 2	TA0034-Angular Rate 2	2000	2000	1.00000000	deg/sec	1650 (CFC1000)	+	Absolute zero	N/A	N/A	---	<input type="checkbox"/>
009	TA0034-Angular Rate 3	TA0034-Angular Rate 3	2000	2000	1.00000000	deg/sec	1650 (CFC1000)	+	Absolute zero	N/A	N/A	---	<input type="checkbox"/>
010	TA0034-Temperature	TA0034-Temperature	---	85	1.00000000	C	1650 (CFC1000)	+	Absolute zero	N/A	N/A	---	<input type="checkbox"/>
012	TA0034-Pressure	TA0034-Pressure	---	16	1.00000000	PSI	1650 (CFC1000)	+	Absolute zero	N/A	N/A	---	<input type="checkbox"/>

Level Triggers

The Level Triggers screen looks slightly different for TSR AIR devices. Level triggers can only be defined on the high g linear acceleration channels, and only one value can be used for level triggering. The trigger can be used on none, one, two, or all directions for acceleration.

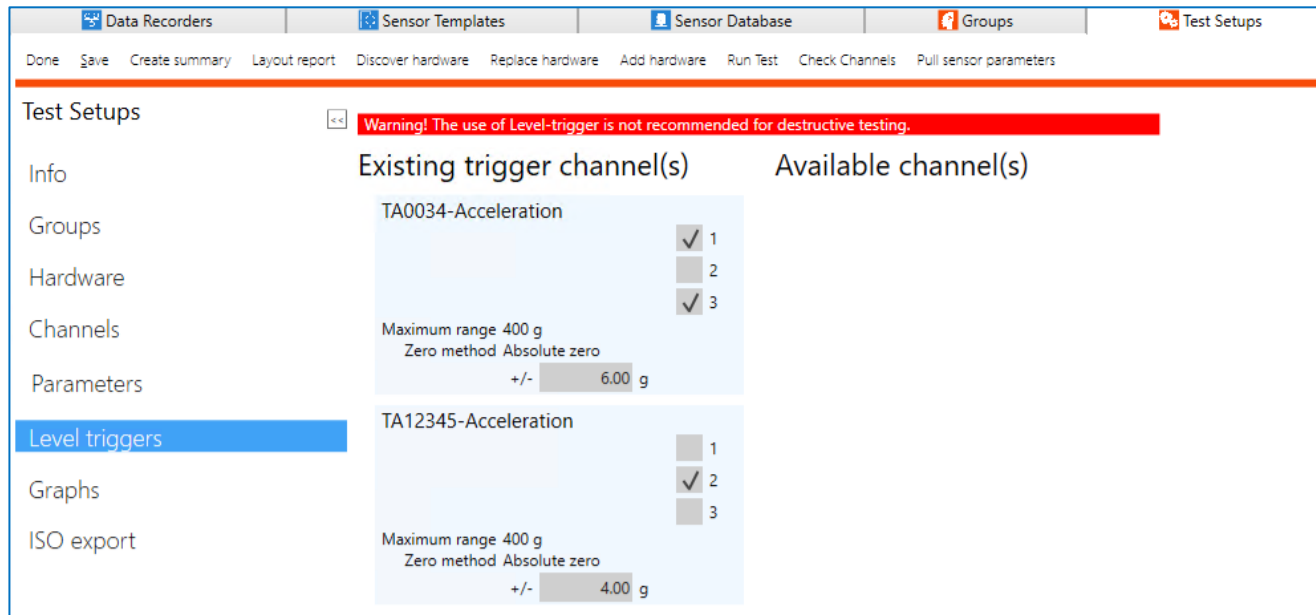

The acceleration channels shown correspond to the axis labels on the outside of the TSR AIR:

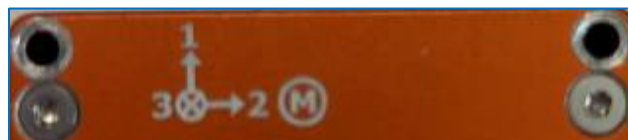

NOTE: *Level triggers are always available in a TSR AIR test even when the level trigger UI is not enabled in System Settings -> Test Settings.*

NOTE: *The "Wake up with motion" option for TSR AIR DAS in Active recording mode does not work when there are level triggers less than or equal to 5g.*

Diagnostics

- TSR AIR devices have limited diagnostic abilities and always have Realtime enabled as part of the TSR AIR diagnostics.

Appendix K: Device Fault IDs

This table shows faults (ExtendedFaultIds) that devices can report while armed.

Error Name	Error Code Bit Position	Comment
EXT_FAULT_TYPE_NONE	((uint32_t) 0)	Success status
EXT_FAULT_TYPE_STATUSLINE_PORT_1_DROPPED	((uint32_t) 1) << 0	
EXT_FAULT_TYPE_STATUSLINE_PORT_2_DROPPED	((uint32_t) 1) << 1	
EXT_FAULT_TYPE_STATUSLINE_PORT_3_DROPPED	((uint32_t) 1) << 2	
EXT_FAULT_TYPE_STATUSLINE_PORT_4_DROPPED	((uint32_t) 1) << 3	
EXT_FAULT_TYPE_STATUSLINE_PWRHUB_DROPPED	((uint32_t) 1) << 4	
Unused	((uint32_t) 1) << 5	Unused
FAULT_FLAG__DEVICE	((uint32_t) 1) << 6	
FAULT_FLAG__DEVICE__KX134	((uint32_t) 1) << 7	KX sensor not detected
FAULT_FLAG__DEVICE__ADXL373	((uint32_t) 1) << 8	ADXL sensor not detected
FAULT_FLAG__DEVICE__BMI270	((uint32_t) 1) << 9	BMI sensor not detected
FAULT_FLAG_DEVICE_FRAM	((uint32_t) 1) << 10	FRAM not detected
FAULT_FLAG_DEVICE_BMI280	((uint32_t) 1) << 11	BME sensor not detected
FAULT_FLAG_DEVICE_MAGNET_SENSOR	((uint32_t) 1) << 12	Magnet sensor not detected
FAULT_FLAG_DEVICE_RTC	((uint32_t) 1) << 13	RTC not detected
FAULT_FLAG_DEVICE_KSZ	((uint32_t) 1) << 14	KSZ note detected
FAULT_FLAG_DEVICE_FPGA	((uint32_t) 1) << 15	FPGA not detected
FAULT_FLAG_DEVICE_NAND	((uint32_t) 1) << 16	NAND not detected
FAULT_FLAG_DEVICE_FUEL_GAUGE	((uint32_t) 1) << 17	
FAULT_FLAG_CONDITION_FRAM_WAKEUP	((uint32_t) 1) << 18	
FAULT_FLAG_CONDITION_RTOS	((uint32_t) 1) << 19	
FAULT_FLAG_CONDITION_NETWORK_CONFIG	((uint32_t) 1) << 20	Invalid network config
FAULT_FLAG_CONDITION_DHCP_FAIL	((uint32_t) 1) << 21	
EXT_FAULT_TYPE_STATUSLINE_SCAP	((uint32_t) 1) << 22	

Error Name	Error Code Bit Position	Comment
EXT_FAULT_TYPE_STATUSLINE_TEMPERATURE	((uint32_t) 1) << 23	
EXT_FAULT_TYPE_STATUSLINE_PORT_1_PG	((uint32_t) 1) << 24	
EXT_FAULT_TYPE_STATUSLINE_PORT_2_PG	((uint32_t) 1) << 25	
EXT_FAULT_TYPE_STATUSLINE_PORT_3_PG	((uint32_t) 1) << 26	
EXT_FAULT_TYPE_STATUSLINE_PORT_4_PG	((uint32_t) 1) << 27	
EXT_FAULT_TYPE_BIST_TEST_FAILED_NUM	((uint32_t) 1) << 28	FPGA BIST Test fail during POR check
EXT_FAULT_TYPE_MAX	((uint32_t) 1) << 31	Limit to 32-bit

Appendix L: Test Setup Import

This section describes the file format used to import Test Setups from a CSV file.

Note: Normal CSV escaping rules are used. Quotes can be used in fields to escape text.

Note: Import files prior to version 6 were only capable of importing sensor settings (see Sensor Table section below). Version 6 and above support importing multiple tables separated by a blank line.

Test Setup Table

This table allows CSV import to create a test setup on import, rather than just importing sensors.

Version	Test Setup Name	Test Setup Description	Recording Mode	SampleRate	PreTriggerSec	PostTriggerSec	Tags
6	MyTestSetupName	My test setup description	S6A_DeviceStreamingOnly	10000		1	1
	Clock ma:Clock master output type	Manage clocks clocks outside of DP	Clock slave input type	Clock slave output type	Manage slave clocks outside of DP		

Field	Version Added	Description
Version	6	The version of the CSV import file. The highest currently supported version is 6, which includes support for hardware assignments, UART settings, stream input and stream output settings, and clock settings. Version 6 is the first import file version that supports additional tables (see Clock Settings Table and DAS Settings Table). Earlier versions only appended additional sensor settings to the CSV fields.
Test Setup Name	6	The name of the test setup that will be created when importing the file as a test setup.
Test Setup Description	6	The description for a test that will be created when importing the file as a test setup.
Recording Mode	6	The recording mode for all DAS in the test. Valid values are: <ul style="list-style-type: none"> • CircularBuffer • Recorder • HybridRecorder • S6A_DeviceStreamingOnly • CircularBufferPlusUART • RecorderPlusUART • MultipleEventCircularBuffer • MultipleEventRecorder

Field	Version Added	Description
		<ul style="list-style-type: none"> • ContinuousRecorder • RecorderAndStreamSubSample • CircularBufferAndStreamSubSample • Active • MultipleEventActive • MultipleEventHybridRecorder • Streaming • Scheduled • Interval • MultipleEventCircularBufferPlusUART • MultipleEventRecorderPlusUART • ContinuousRecorderPlusUART • RAMActive • MultipleEventRAMActive • ContinuousRecordOnBoot
SampleRate	6	The overall sample rate for DAS in the test. This is the sample rate for all DAS in the test if the DAS settings table is not used.
PreTriggerSec	6	Positive value for pre trigger seconds to record for recording modes that have known pre-trigger time, like circular buffer.
PostTriggerSec	6	Positive value for post trigger seconds to record, or overall test length for modes which don't have a trigger.
Tags	6	Tags to apply to the test to control test visibility.

Sensor Table

The sensor table lists all sensors to be imported. Earlier versions of the import file (5 and below) only included the sensor data, with no additional tables supported. Many fields in this table are optional. When exporting, all fields including optional fields will be included in the export file.

Field	Version Added	Description
DatabaseReferenceNumber	0	
SensorSN	0	Note: sensor serial numbers are assumed to be unique and not repeated in a test setup.
ChannelName	0	
Location	0	
LaboratoryCode	0	
CustomerCode	0	
PartialISOCCode	0	
CommentField	0	
SensorType	0	
Manufacturer	0	
Model	0	
Axis	0	(X, Y, Z)
Dimension	0	
EU	0	
FullScale	0	(EU)
Exc	0	(VDC)
OutputAtEXCFSmV	0	(mV)
Sensitivity	0	(mV/V/EU)
Proportional	0	(Yes, No)
DesiredRange	0	(EU)
BRIDGE	0	(Full, Half)
UseShuntCal	0	(Yes, No)
BridgeResistance	0	(Ohm)
ShuntResistorValue	0	(Ohms)
EquivalentEUShuntResistor	0	
BypassAAFilter	0	(Yes, No)

Field	Version Added	Description
InvertSignal	0	(Yes, No)
RemoveOffset	0	(Yes, No)
OffsetToleranceLow	0	(mV)
OffsetToleranceHigh	0	(mV)
FilterClass	0	
SoftwareZeroReference	0	(Pre, Avg, 0mV)
SoftwareZeroEquivalentEU	0	
SensorID	0	
Received	0	
LastCal	0	
DueCal	0	
Due	0	
Tech	0	
Group1	0	
Group2	0	
Group3	0	
Group4	0	
Group5	0	
Category	0	
IRTRACCExponent	0	
TwoVoltExcSensitivity	2	
FiveVoltExcSensitivity	2	
TenVoltExcSensitivity	2	
RangeLow	2	
RangeMedium	2	
RangeHigh	2	
SupportedExcitation	2	
BridgeType	2	
Unipolar	2	Used to indicate that a sensor's output is 0 → Sensor max range, not +/- Sensor max range.
AxisNumber	2	
NumberOfAxes	2	
CallInterval	2	
Polarity	2	

Field	Version Added	Description
PhysicalDimension	2	
Direction	2	
InitialOffset	2	
NonLinear	2	
ZeroMethod	2	
ZeroMethodStart	2	
ZeroMethodEnd	2	
BridgeLegMode	2	
Created	2	
TimesUsed	2	
CouplingMode	2	
DelayMS	2	
DigitalOutputDelayMS	2	
DurationMS	2	
DigitalOutputDurationMS	2	
DigitalOutputMode	2	
LimitDuration	2	
SquibFireMode	2	
SquibMeasurementType	2	
SquibOutputCurrent	2	
DigitalScaleMultiplier	2	
DigitalInputMode	2	
NonLinearCalibration	2	
DisplayUnits	2	
AtCapacity	2	
CapacityOutputIsBasedOn	2	
SensitivityUnits	2	
CheckOffset	2	
Broken	2	
DoNotUse	2	
ISOChannelName	2	
UserCode	2	
UserChannelName	2	

Field	Version Added	Description
AdditionalLinearSensitivity	2	
AdditionalLinearZeroMethod	2	
AdditionalLinearZeroMethodStart	2	
AdditionalLinearZeroMethodEnd	2	
AdditionalInitialOffsets	2	
GroupName	3	
GroupType	3	
DAS serial number	6	Optional. Identifies which DAS the channel will be assigned to. For the channel to be assigned to a DAS channel, a DAS channel index must also be provided.
DAS channel index	6	Optional. Identifies which channel on the DAS the sensor will be assigned to. Channel numbers are 0-n with analog channels first, then UART, then stream output channels. For a SLICE6 AIR this means 0-5 are analog channels, 6 is the UART channel, and 7 is the stream output channel.
Stream profile	6	Specifies the stream profile that should be used for streaming output settings. The default value is CH10_ANALOG_2HDR. Valid values include: <ul style="list-style-type: none"> • RTCStreaming • DTS_UDP • CH10_MANUAL_CONFIG • CH10_PCM128_MM • CH10_ANALOG • CH10_PCM_STANDARD • CH10_PCM_SUPERCOM • CH10_PCM_128BIT_2HDR • CH10_ANALOG_2HDR • CH10_PCM_STANDARD_2HDR • CH10_PCM_SUPERCOM_2HDR • TMNS_PCM_STANDARD • TMNS_PCM_SUPERCOM • IENA_PTYPE_STREAM • UART_STREAM
UDP address	6	Optional. The UDP address streams will receive or send on. Defaults to UDP://239.1.2.10:8400
Time channel Id	6	Optional. The time channel ID for streaming profiles which have a time channel with an id. Valid values are 0-255. Default is 1.
Data channel Id	6	Optional. The data channel id for streaming profiles which have a data channel with an id. Valid values are 0-255. Default is 3.
Stream output configuration	6	Optional. Specifies the configuration for stream outputs. Format is a comma-separated string with 8 integer positions. Default is (1,6,60,0,0,0,0,0). The fields which make up the string are:

Field	Version Added	Description
		<ul style="list-style-type: none"> • TMNS_PCMSubFrameID, • TMNS_MsgId, • TMNS_PCMMinorPerMajor, • TMNS_TMATSPortNumber, • IENAUdp_PortNumber, • TMNS5, • TMNS6, • TMNS7 <p>TMNS5, TMNS6, and TMNS7 are not currently used.</p>
IRIG time packet interval ms	6	Optional. The frequency of sending IRIG time packets for protocols which send time packets. Integer value. Default is 500ms.
TMATS packet interval ms	6	Optional. The frequency of sending TMATS packets for protocols which send TMATS packets. Integer value. Default is 1000ms.
Baud rate	6	Optional. Baud rate for UART configurations. Integer value.
Data bits	6	Optional. Number of data bits for UART configurations. Integer value. Default is 8.
Stop bits	6	Optional. Stop bit length for UART configurations. Default is 'None'. Valid values include: <ul style="list-style-type: none"> • None • One • Two • OnePointFive
Parity	6	Optional. Parity bit configuration for UART configurations. Default is 'None'. Valid values include: <ul style="list-style-type: none"> • None • Odd • Even • Mark • Space
Data format	6	Optional. Data format for UART data that is downloaded from a device. Default is 'Binary'. Valid values include: <ul style="list-style-type: none"> • Binary • PlainText • NMEA
Test user code	6	Optional. Allows for setting a user code on the test channel.
Test user channel name	6	Optional. Allows for setting a user channel name on a test channel.

Field	Version Added	Description
Test isocode	6	Optional. Allows for setting an ISO 13499 ISO Code on a test channel.
Test iso channel name	6	Optional. Allows for setting an ISO 13499 ISO channel name on a test channel.

Clock Settings Table

Optional table that allows configuration of the clock settings for a test to be imported. The order of the columns does not matter. There should be a blank line between the previous table and this table, as well as after this table before the next table. Added in CSV import file version 6.

Version	Test Setup Name	Test Setup Description	Recording Mode	SampleRate	PreTrigger	PostTrigger	Tags
6	MyTestSetupName	My test setup description	S6A_DeviceStreamingOnly	10000	1	1	
Clock master input type	Clock master output type	Manage master clocks outside of DP	Clock slave input type	Clock slave output type	Manage slave clocks outside of DP		
IRIG	None	TRUE	None	None	TRUE		
DAS Serial	DAS Sample Rate	PTP domain id	Clock master				
S6A0001	20000		1	TRUE			
S6A0002	10000		1	FALSE			

Field	Version Added	Description
Clock master input type	6	<p>Optional. If present, this field will define how the clock masters in the test will behave for their input time. The default value is 'None'.</p> <p>Valid values include:</p> <ul style="list-style-type: none"> • None • PTP • IRIG • GPS • OnePPS • PTP_OnePPS • IRIG_OnePPS • GPS_OnePPS

Field	Version Added	Description
Clock master output type	6	<p>Optional. If present, this value will determine how clock masters will output time to other downstream devices. The default value is 'None'.</p> <p>Valid values include:</p> <ul style="list-style-type: none"> • None • PTP • PTP_OnePPS • PTPMasterE2E • PTPMasterP2P • PTPBoundaryE2E • OnePPS • PTPMasterE2E_OnePPS • PTPMasterP2P_OnePPS • PTPBoundaryE2E_OnePPS • PTPBoundaryP2P_OnePPS
Manage master clocks outside of DP	6	<p>Optional. Use this setting if clocks are to be managed outside of DataPRO – DataPRO will not set the clock settings. This setting is mutually exclusive with setting clock settings, but the clock settings override, so if both are provided this setting is ignored and the clock settings are used.</p> <p>Valid values are TRUE and FALSE.</p>
Clock slave input type	6	<p>Optional. If present, this field will define how the clock slaves in the test will behave for their input time. The default value is 'None'.</p> <p>Valid values include:</p> <ul style="list-style-type: none"> • None • PTP • IRIG • GPS • OnePPS • PTP_OnePPS • IRIG_OnePPS • GPS_OnePPS

Field	Version Added	Description
Clock slave output type	6	<p>Optional. If present, this value will determine how clock slaves will output time to other downstream devices. The default value is 'None'.</p> <p>Valid values include:</p> <ul style="list-style-type: none"> • None • PTP • PTP_OnePPS • PTPMasterE2E • PTPMasterP2P • PTPBoundaryE2E • OnePPS • PTPMasterE2E_OnePPS • PTPMasterP2P_OnePPS • PTPBoundaryE2E_OnePPS • PTPBoundaryP2P_OnePPS
Manage slave clocks outside DP	6	<p>Optional. Use this setting if clocks are to be managed outside of DataPRO – DataPRO will not set the clock settings. This setting is mutually exclusive with setting clock settings, but the clock settings override, so if both are provided this setting is ignored and the clock settings are used.</p> <p>Valid values are TRUE and FALSE.</p>

DAS Settings Table

Optional table that allows configuration of DAS settings for a test to be imported. If this table is present, it should always start with the DAS serial field, and must include the DAS sample rate field. The order of the other columns does not matter. There should be a blank line between the previous table and this table, as well as after this table before the next table. Added in CSV import file version 6.

4	Clock master input type	Clock master output type	Manage clocks clocks outside of DP	Clock slave input type
5	IRIG	None	TRUE	None
6				
7	DAS Serial	DAS Sample Rate	PTP domain id	Clock master
8	S6A0001	20000	1	TRUE
9	S6A0002	10000	1	FALSE
10				
11	Database Reference Number	Sensor SN	Channel Name	Location
12		1 BridgePlug1		
13		2 BridgePlug2		

Field	Version Added	Description
DAS serial	6	The serial number of the DAS that settings should be set for. Required first field if table is present.
DAS sample rate	6	The sample rate to record or stream at. Should be an integer value. Required if table is present.
PTP domain id	6	Optional. If present, allows setting the PTP domain id for DAS. Valid values are in the range of 1-255.
Clock master	6	Optional. If present, determines which DAS should operate as the clock master for other devices downstream. Valid values are TRUE and FALSE.

Appendix M: Unipolar Sensors

Sensors in DataPRO are ordinarily bipolar, centered around 0mV. For example, if a sensor has a range of 2000g, perfectly centered on 0mV with an input voltage of 5V, then in an ideal world -2000g would be measured around -2.5V and 2000g would be measured around 2.5V.

	<input type="checkbox"/> Broken	<input type="checkbox"/> Do not use	<input type="checkbox"/> Inspect before use	<input type="button" value="Approve sensor for use"/>
Channel type	Analog			
Manufacturer				
Model				
Serial number	Sample Sensor			
Info				
Sensor max range	2,000.00			
Units	g			
Polarity	+			
Sensor type	Full bridge			
Last Calibration Date	12/31/2024			
Sensitivity Details	Sensitivity: 0.20000000 Sensitivity Units: mV/EU			

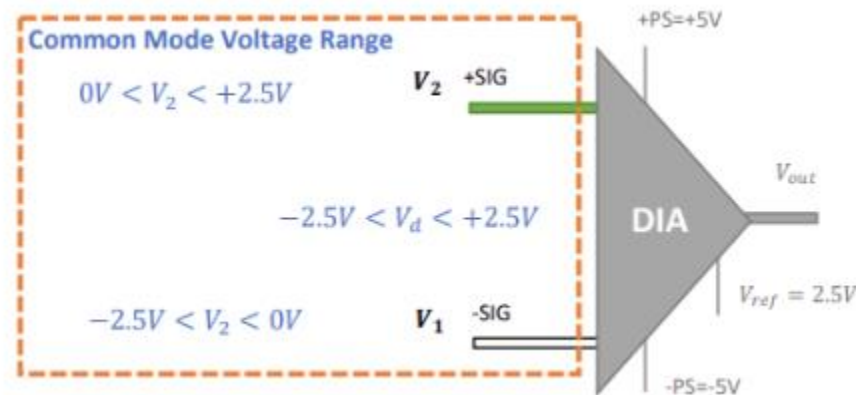

Before a gain is applied, there are considerations made for both a safety overhead as a percent of the full scale desired, as well as adjustments in the actual input range that can be reliably measured.

Some sensors, like a Knee Pot, for example, only have measurements of interest in one direction. Instead of being centered on 0, the sensor may go from 0mm to 36mm. Using bipolar sensor settings on this type of sensor may result in a larger gain than needed being used, resulting in a loss of fidelity in measurement. In such cases, the Unipolar sensor setting should be used.

The image shows a configuration window titled "Display" with several fields and controls:

- Name: [Greyed out]
- ISO Code: ??????????????A
- ISO Name: [Greyed out]
- Default Filter: 1650 (CFC1000) [Dropdown arrow]
- Bypass AAF: [Greyed out]
- Tags: [Greyed out]
- Unipolar: (highlighted with a red square)
- User value 1: [Greyed out]
- User value 2: [Greyed out]
- User value 3: [Greyed out]

When Unipolar is checked, an attempt is made to measure the sensor with 0EU at the bottom of the measured input and the max EU at the max of the measured input. For the 2000g sensor mentioned previously, now -2.5V would be 0 EU and 2.5V would be 2000g.

Note that software zeroing can work against the user when using unipolar sensors. Average overtime will set 0 EU to whatever output of the sensor is over the averaging window. But this means that 0 EU will no longer be at -2.5V unless the averaging window is done while the sensor is in that corresponding state. There's a similar problem with Diagnostic zero: 0 EU will be set to whatever the output of the sensor is during diagnostics. If the sensor is either fully extended or

fully collapsed this setting might work, but some sensor types such as a thermocouple will probably not work well with either zeroing method.

Another issue to consider when using the Unipolar setting is the EU output of the sensor at 0V. Taking a thermocouple as an example, it may measure 0°C to 1250°C, but it does not have an evenly split negative and positive range, so the half-point of the range is not located at 0V. When dealing with a Halfway Point (HP) that is not centered at zero, the sensor property Initial EU can be used to correct the output. For the example here, the midpoint of the range is 625°C. The output can then be calibrated by setting Initial EU to 1/2 sensor range + some calibration amount. The calibration amount could either be straight from a cal-sheet or determined by using a calibrated thermometer or simulator. It is important to verify that output is not clipped when dealing with sensors where the HP is not around 0V.

More information is available from DTS support at the [DTS Help Center](#).

See also: [Bipolar vs. Unipolar Sensors](#)

Document Revision History

Rev	Date	By	Description
12	April 2025	AD	Updates for v4.4
11	Jan 2025	AD	Updates for v4.3
10	Mar 2024	AD	Updates for v4.2
9	Aug 2023	AD	Updates for v4.1
8	May 2023	AD	Updates for v4.0
7	Jan 2023	AD	Updates for v3.3
6	6 Nov 2021	PV	Updates for v3.1
5	7 April 2020	JC/MR	Updates for v3.0
4	3 April 2019 28 May 2019	JC EK	Updates for v2.0.
3	6 June 2018	JC	Updates for v1.9.
2	2 Oct 2017	JC	Updates for v1.4.
1	6 Sept 2016	DQ/EK	Updated the Binary File (Appendix C) description for CRC32. Completed missing sections and updated entire document for v1.1.
0	10 Dec 2015	EK/TR	Initial release.